

INTRODUCTION	1
PREPARATION	2
SERVICE SPECIFICATIONS	3
DIAGNOSTICS	5
ENGINE CONTROL SYSTEM	10
FUEL	11
EMISSION CONTROL	12
INTAKE	13
ENGINE MECHANICAL	14
EXHAUST	15
COOLING	16
LUBRICATION	17
IGNITION	18
STARTING & CHARGING	19
FRONT SUSPENSION	26
REAR SUSPENSION	27
TIRE & WHEEL	28
DRIVE SHAFT / PROPELLER SHAFT	30
BRAKE	32
PARKING BRAKE	33
AUTOMATIC TRANSMISSION / TRANS	40
MANUAL TRANSMISSION/TRANSAXLE	41
CLUTCH	42
STEERING COLUMN	50
POWER STEERING	51
HEATER & AIR CONDITIONER	55
SUPPLEMENTAL RESTRAINT SYSTEM	60

SEAT BELT	61
LIGHTING	65
WIPER & WASHER	66
AUDIO & VISUAL SYSTEM	67
WIRING	68
COMMUNICATION SYSTEM	69
WINDSHIELD/WINDOWGLASS/MIRROR	70
INSTRUMENT PANEL/METER	71
SEAT	72
THEFT DETERRENT & DOOR LOCK	73
SLIDING ROOF/CONVERTIBLE	74
ENGINE HOOD/DOOR	75
EXTERIOR/INTERIOR TRIM	76
VEHICLE CONTROL SYSTEM	80
CRUISE CONTROL	82
MAINTENANCE	99
ALPHABETICAL INDEX	

FOREWORD

This manual (Volume 2) contains engine, chassis and body and electrical service procedures for the 2004 COROLLA.

Applicable models: ZZE130 series

For preparation, specifications and diagnostics procedures, refer to VOLUME 1 (Pub. No. RM1037U1).

The manual is divided into 39 sections with a thumb index for each section at the edge of the pages.

Please note that the publications below have also been prepared as relevant service manuals for the components and systems in this vehicles.

Manual Name	Pub.No.
• A245E, A246E Automatic Transaxle Repair Manual	RM941U
• 2004 COROLLA Electrical Wiring Diagram	EWD533U

All information in this manual is based on the latest product information at the time of publication. However, specifications and procedures are subject to change without notice.

TOYOTA MOTOR CORPORATION

©2003 **TOYOTA MOTOR CORPORATION**

All rights reserved. This book may not be reproduced or copied, in whole or in part, without the written permission of Toyota Motor Corporation.

First Printing: May 9, 2003 01-030509-00

HOW TO USE THIS MANUAL

0103I-08

GENERAL INFORMATION

1. GENERAL DESCRIPTION

- (a) This manual is made in accordance with SAE J2008.
- (b) Generally, repair operations can be separated in the following 3 main processes:
 1. Diagnosis
 2. Removing/Installing, Replacing, Disassembling/Reassembling, Checking and Adjusting
 3. Final Inspection
- (c) This manual explains the 1st process of "Diagnosis" (found in the "Diagnostics" section), the 2nd process of "Removing and Installing, Replacing, Disassembling, Installing and Checking, and Adjusting", but the 3rd process of "Final Inspection" is omitted.
- (d) The following essential operations are not written in this manual. However, these operations must be performed in actual situations.
 - (1) Operations with a jack or lift
 - (2) Cleaning of a removed part when necessary
 - (3) Visual check

2. INDEX

- (a) An alphabetical INDEX section is provided at the end of the book as a reference to help you find the item to be repaired.

3. PREPARATION

- (a) Use of special service tools (SST) and special service materials (SSM) may be required, depending on the repair situation. Be sure to use SST and SSM when they are required and follow the working procedure properly. A list of SST and SSM is in the Preparation section of this manual.

4. REPAIR PROCEDURES

- (a) Component drawing is placed under the title where necessary.
- (b) Non-reusable parts, grease application area, precoated parts and tightening torque are specified in the component drawings.

Example:

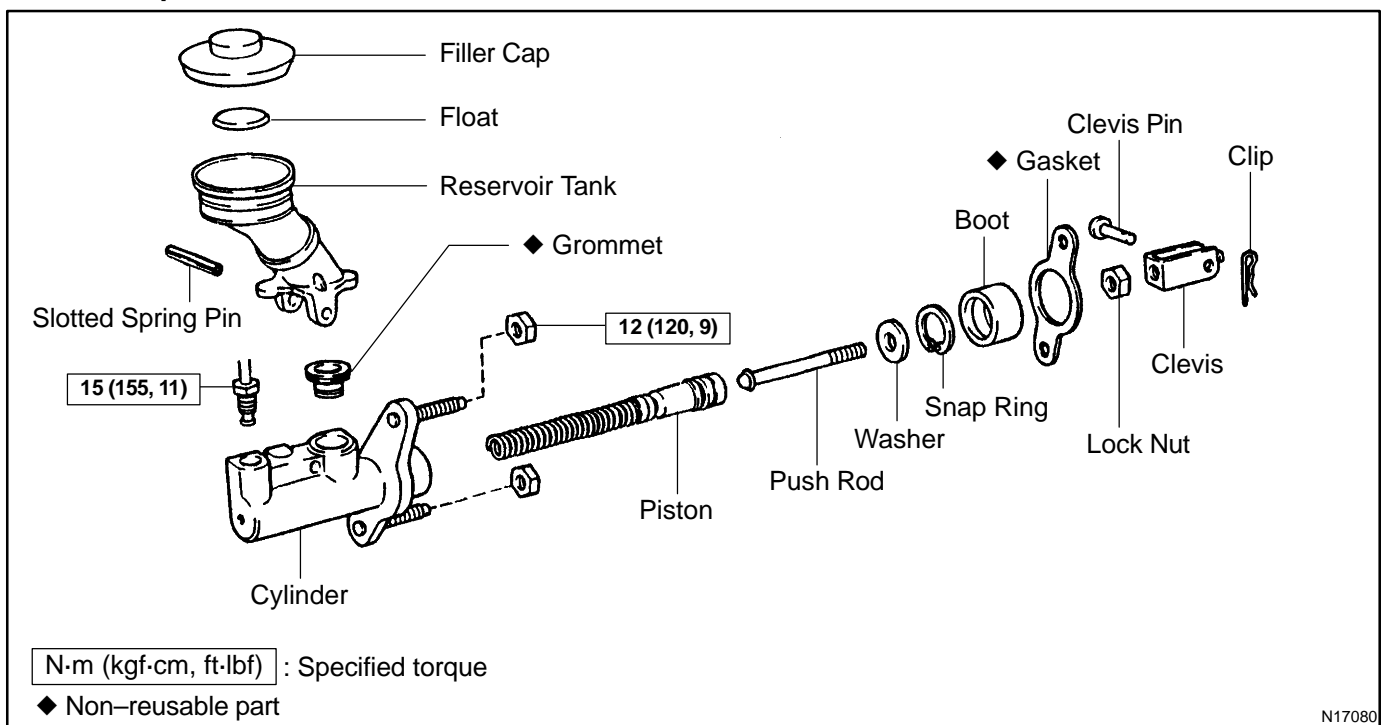

- (c) Tightening torque, grease application area, and non-reusable parts are described as important points in the procedures.

NOTICE:

There are cases where such information can only be explained by using an illustration. In these cases, all the information such as torque, oil, etc. are described in the illustration.

- (d) Installing procedures are performed in the reverse order of the removal and only the important points are described.
- (e) Only items with points are described in the procedure, and the operational portion and content are placed using an illustration. In the explanations, details of the operational method, standard value and notices are placed.
- (f) There may be a case where the illustrations of similar models are used. In that case, specific details may be different from the actual vehicle.
- (g) The procedures are presented in a step-by-step format:
- (1) The illustration shows what to do and where to do it.
 - (2) The task heading tells what to do.
 - (3) The explanation text tells how to perform the task and gives other information such as specifications and warnings.

Example:

Illustration:

what to do and where

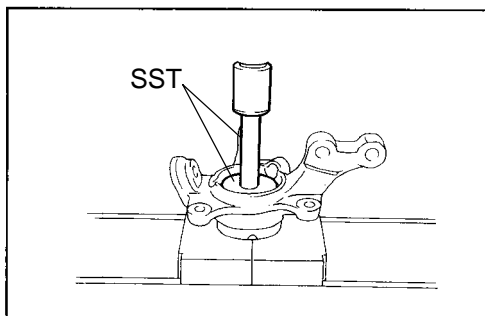

- Task heading: what you will be doing*
- 14. INSTALL FRONT AXLE HUB LH BEARING**
- (a) Using SST and a press, install a new bearing to the steering knuckle. *Detailed text: how to perform task*
- SST 09950-60020 (09951-00720), 09950-70010
(09951-07100)
- Set part No.* *Component part No.*

D31132

HINT:

This format provides an experienced technician with a FAST TRACK to the necessary information. The task heading can be read at a glance when necessary and the text below provides detailed information. Important specifications and warnings always are written in bold type to stand out from the rest of the text.

5. SERVICE SPECIFICATIONS

- (a) Specifications are presented in bold type throughout the manual. You never have to leave the procedure to look up your specifications. The specifications are also found in the Service Specifications section for quick reference.

6. TERMS DEFINITION

CAUTION	Indicates the possibility of injury to you or other people.
NOTICE	Indicates the possibility of damage to the components being repaired.
HINT	Provides additional information to help you to perform the repair efficiently.

7. SI UNIT

- (a) The units given in this manual are primarily expressed according to the SI UNIT (International System of Units), and alternately expressed in the metric system and in the English System.

Example:

Torque: 30 N·m (310 kgf·cm, 22 ft·lbf)

IDENTIFICATION INFORMATION

VEHICLE IDENTIFICATION AND SERIAL NUMBERS

01031-06

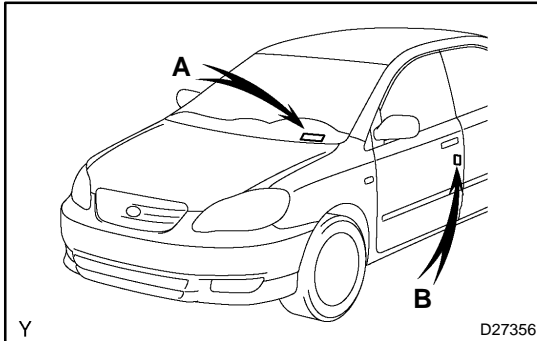

1. VEHICLE IDENTIFICATION NUMBER

- (a) The vehicle identification number is stamped on the vehicle identification number plate and certification label, as shown in the illustration.

A: Vehicle Identification Number Plate

B: Certification Label

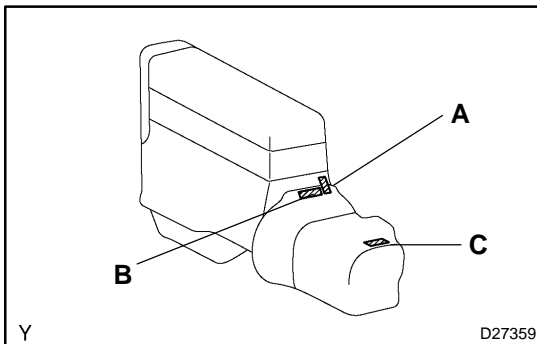

2. ENGINE SERIAL NUMBER AND TRANSAXLE SERIAL NUMBER

- (a) The engine serial number is stamped on the cylinder block of the engine, and the transaxle serial number is stamped on the housing, as shown in the illustration.

A: 1ZZ-FE

B: C59

C: A245E

REPAIR INSTRUCTION

010D8-02

PRECAUTION

1. BASIC REPAIR HINT

(a) HINTS ON OPERATIONS

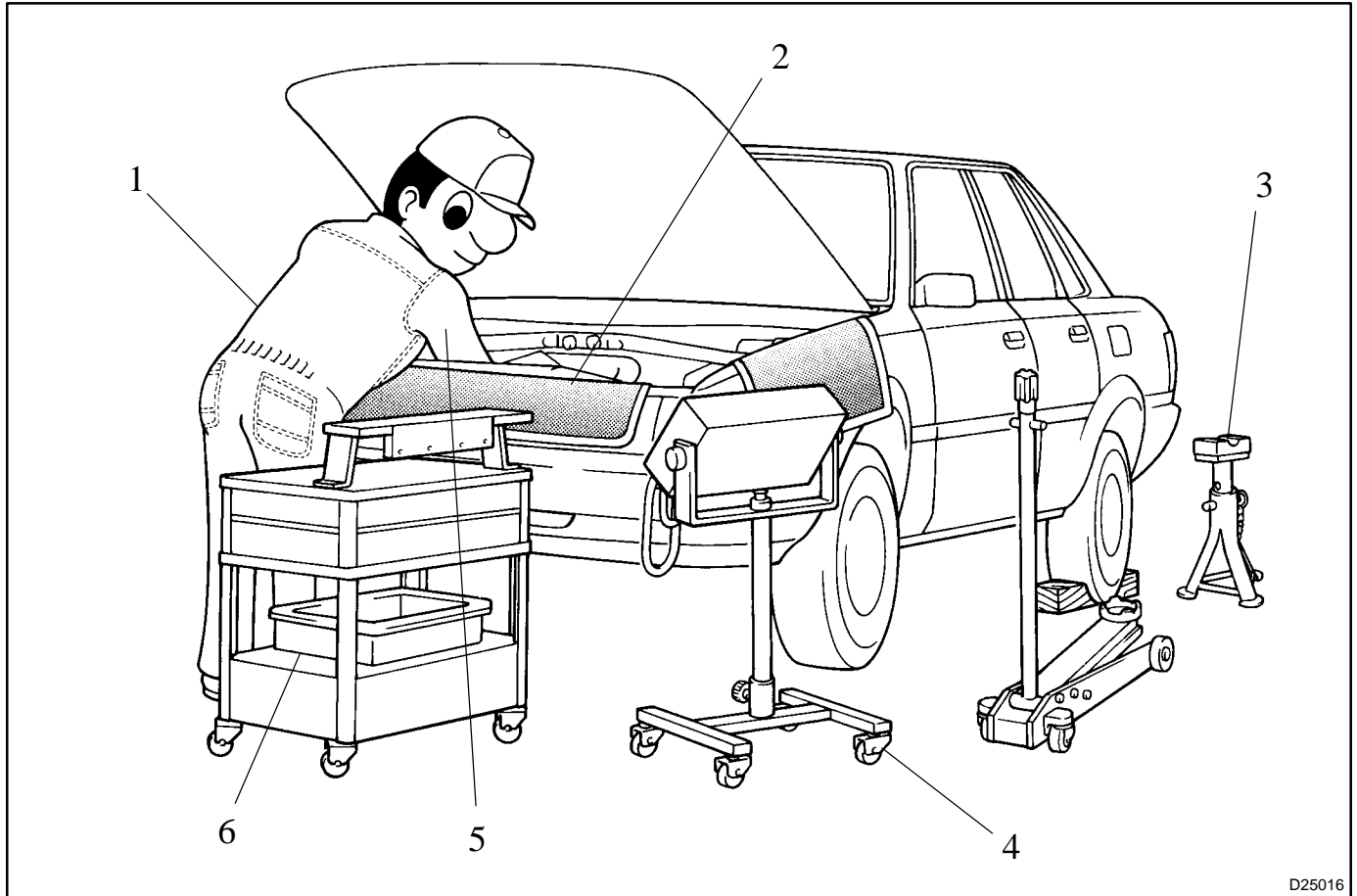

D25016

1	Looks	<ul style="list-style-type: none"> • Always wear a clean uniform. • Hat and safety shoes must be worn.
2	Vehicle protection	<ul style="list-style-type: none"> • Set a grill cover, fender cover, seat cover and floor mat before starting the operation.
3	Safe operation	<ul style="list-style-type: none"> • In case of working with 2 or more persons, be sure to check safety of one another. • When working with the engine running, pay attention to the ventilation of the workshop. • In case of operating on high-temperature parts, rotating, moving and vibrating parts, pay attention not to burn or injure yourself. • When jacking up the vehicle, be sure to support the specified location with a safety stand. • When lifting up the vehicle, apply a safety equipment.
4	Preparation of tools and measuring gauge	<ul style="list-style-type: none"> • Before starting operation, prepare a tool stand, SST, gauge, oil, shop rag and parts for replacement.
5	Removal and installation, disassembly and assembly operations	<ul style="list-style-type: none"> • Diagnose with a thorough understanding of the trouble phenomenon and perform effective operations. • Before removing the parts, check the assembly for general condition, deformation and damage. • When the structure is complicated, take a note or put match marks so as not to make mistakes that affect the function of the parts. • Clean and wash the removed parts if necessary, and assemble them after a thorough check.
6	Removed parts	<ul style="list-style-type: none"> • Place the removed parts in the correct order to avoid mixing up or making them dirty. • As for non-reusable parts such as gasket, O-ring, and self lock nut, change them to new ones following the instruction of this manual. • Sort out the parts for replacement in a box and show them to the customer.

(b) JACKING UP AND SUPPORTING VEHICLE

- (1) Care must be taken when jacking up and supporting the vehicle. Be sure to lift and support the vehicle at the proper locations (See page 01-17).

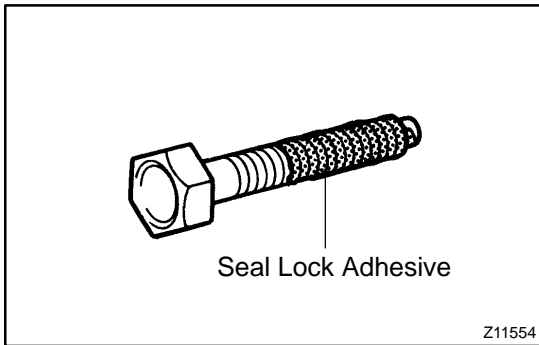

(c) PRECOATED PARTS

- (1) Precoated parts are bolts, nuts, etc. that are coated with a seal lock adhesive at the factory.
- (2) If a precoated part is retightened, loosened or caused to move in any way, it must be recoated with the specified adhesive.
- (3) When reusing precoated parts, clean off the old adhesive and dry the part with compressed air. Then apply the specified seal lock adhesive to the bolt, nut or threads.

NOTICE:

Perform the torque checking with the lower limit value of the torque tolerance.

- (4) Depending on the seal lock agent to apply, there may be a case where it is necessary to leave it for a specified time until it hardens.

(d) GASKETS

- (1) When necessary, use a sealer on gaskets to prevent leaks.

(e) BOLTS, NUTS AND SCREWS

- (1) Carefully observe all the specifications for tightening torques. Always use a torque wrench.

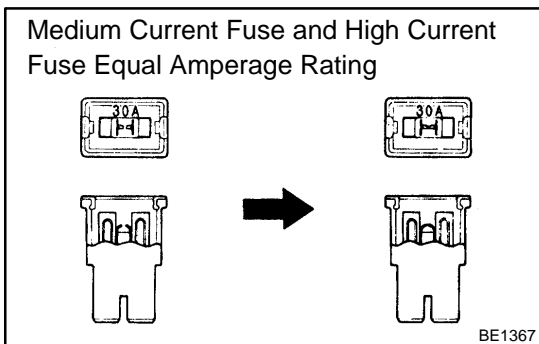

(f) Fuses.

- (1) When replacing fuses, be sure that a new fuse has the correct amperage rating. DO NOT exceed the rating, or use one with a lower rating.

Illustration	Symbol	Part Name	Abbreviation
<p>BE5594</p>	<p>IN0365</p>	FUSE	FUSE
<p>BE5595</p>	<p>IN0366</p>	MEDIUM CURRENT FUSE	M-FUSE
<p>D27353</p>	<p>IN0367</p>	HIGH CURRENT FUSE	H-FUSE

(g) CLIPS

(1) The removal and installation methods of typical clips used in body parts are shown in the table below.

HINT:

If the clip is damaged during the a procedure, always replace it with a new clip.

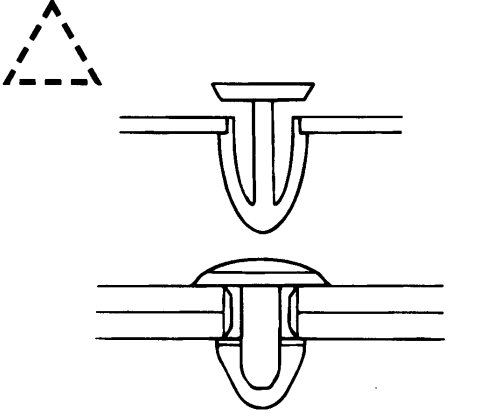
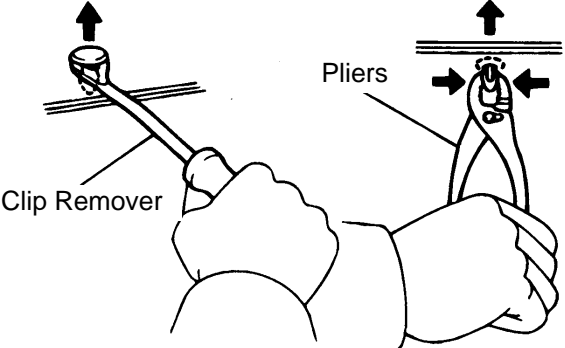
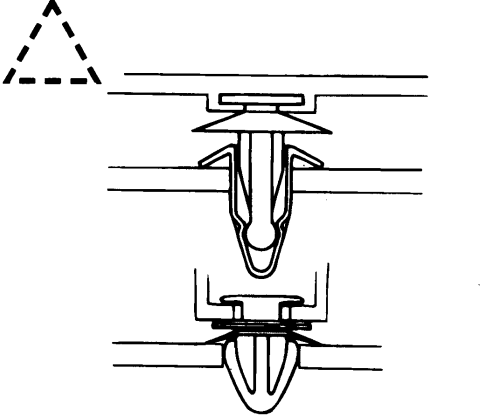
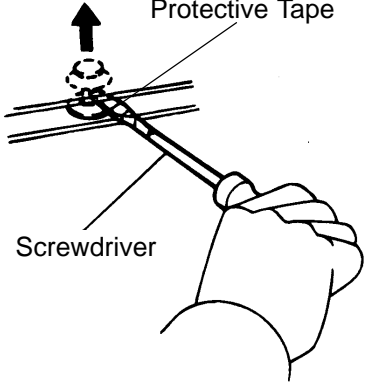
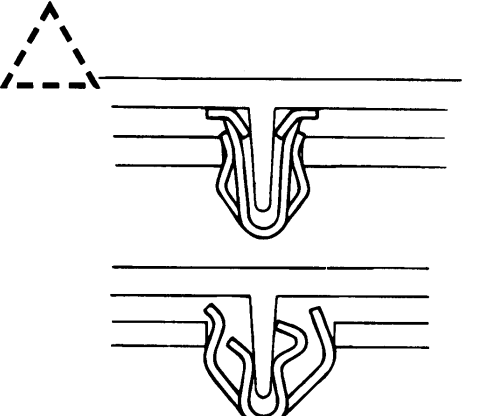
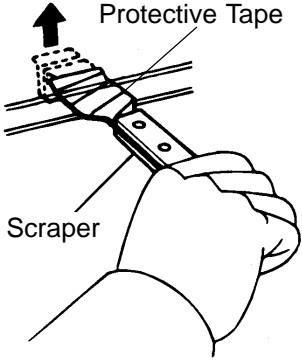
Shape (Example)	Removal/Installation
	
	
	

D25786

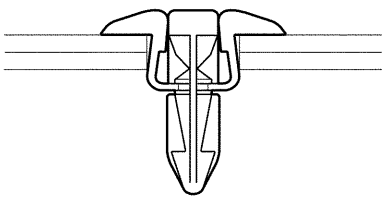
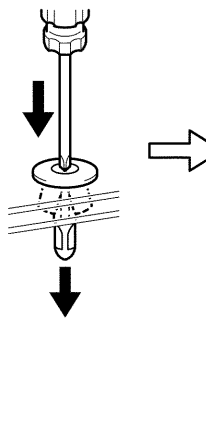
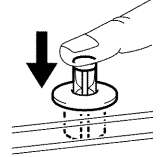
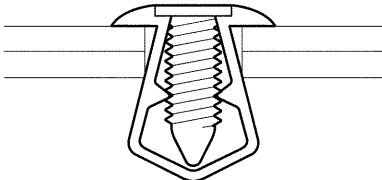
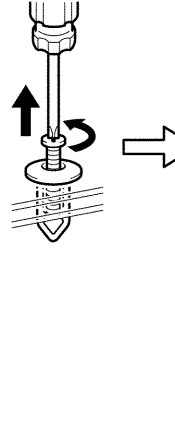
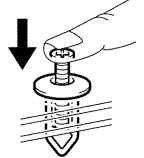
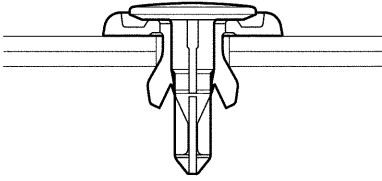
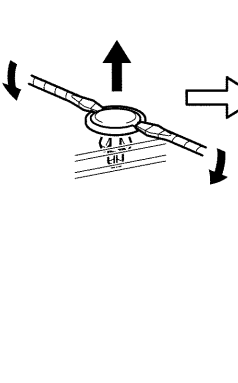
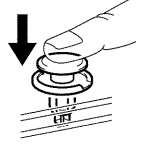
Shape (Example)	Removal/Installation	
	<p>Removal</p> 	<p>Installation</p> 
	<p>Removal</p> 	<p>Installation</p> 
	<p>Removal</p> 	<p>Installation</p> 

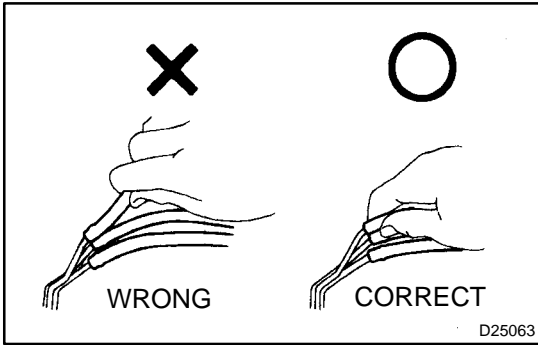

- (h) REMOVAL AND INSTALLATION OF VACUUM HOSES
- (1) To disconnect vacuum hoses, pull them by holding the end, not the middle of the hose.

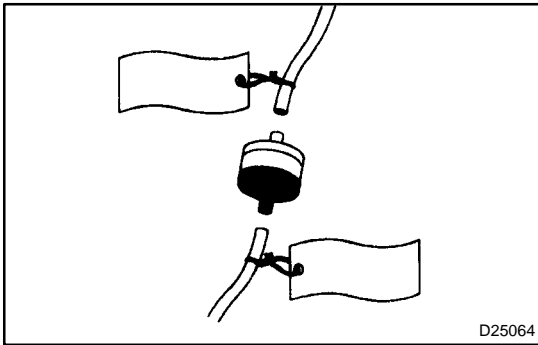

- (2) When disconnecting vacuum hoses, use tags to identify where they should be reconnected.
- (3) After completing the job, make a double check whether the vacuum hoses are properly connected. A label under the hood shows the proper layout.
- (4) When using a vacuum gauge, never force the hose onto a connector that is too large. Use a step-down adapter for adjustment. Once the hose has been stretched, it may leak air.

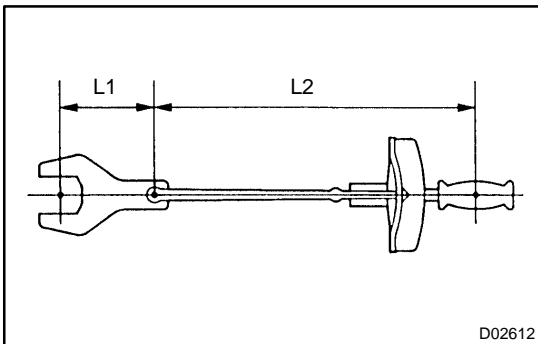

- (i) TORQUE WHEN USING TORQUE WRENCH WITH EXTENSION TOOL

- (1) In case of tightening with a torque wrench which has an extended length by combining the torque wrench with SST or extension tool, if you tighten until the reading of the torque wrench reaches the specified torque value, the actual torque becomes excessive.
- (2) In this manual, only the specified torque is described. In case of using SST or an extension tool, calculate the reading of the torque wrench by the following formula.
- (3) Formula $T' = T \times L2 / (L1 + L2)$

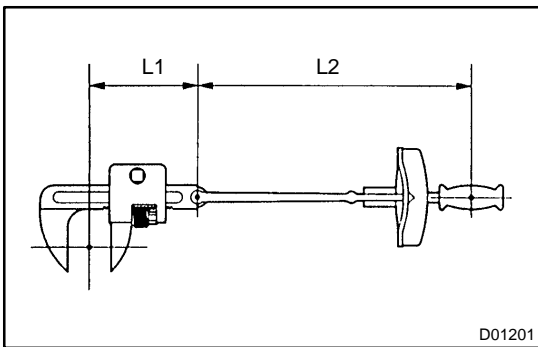

T'	Reading of torque wrench {N·m (kgf·cm, ft·lbf)}
T	Torque {N·m (kgf·cm, ft·lbf)}
L1	Length of SST or extension tool (cm)
L2	Length of torque wrench (cm)

2. FOR VEHICLES EQUIPPED WITH SRS AIRBAG AND SEAT BELT PRETENSIONER

HINT:

The vehicle is equipped with an SRS (Supplemental Restraint System), such as the horn button assembly, the instrument panel passenger airbag assembly, the front seat airbag assembly, the center airbag sensor assembly, the front airbag sensor, the side airbag sensor and the seat belt pretensioner.

Failure to carry out the service operations in the correct sequence could cause the supplemental restraint system to unexpectedly deploy during servicing. It may lead to a serious accident.

Furthermore, if a mistake is made in servicing the supplemental restraint system, it is possible that the SRS will fail to operate when required. Before servicing (including removal or installation of parts, inspection or replacement), be sure to read the following items carefully. Then follow the correct procedure described in this manual.

(a) GENERAL NOTICE

- (1) Malfunction symptoms of the supplemental restraint system are difficult to confirm, so the diagnostic trouble codes become the most important source of information when troubleshooting. When troubleshooting the supplemental restraint system, always check the diagnostic trouble codes before disconnecting the battery (See page 05-424).
- (2) Work must be started after 90 seconds from the time the ignition switch is turned to the "LOCK" position and the negative (-) terminal cable is disconnected from the battery.
(The supplemental restraint system is equipped with a back-up power source, so, if work is started within 90 seconds after disconnecting the negative (-) terminal cable from the battery, the SRS may deploy.)
When the negative (-) terminal cable is disconnected from the battery, memory of the clock and audio systems will be cancelled. So, before starting work, make a record of the memorized contents in each memory system. Then, when work is finished, reset the clock and audio systems as before. To avoid erasing the memory in each memory system, never use a back-up power supply from another battery.
- (3) Even in case of a minor collision where the SRS does not deploy, the horn button assembly, the instrument panel passenger airbag assembly, the front seat airbag assembly and the seat belt pretensioner should be inspected (See pages 60-14, 60-26, 60-32 and 61-9).
- (4) Never use SRS related parts from another vehicle. When replacing parts, replace them with new parts.
- (5) Before repairs, remove the airbag sensor if shocks are likely to be applied to the sensor during repairs.
- (6) Never disassemble and repair the airbag sensor assembly, the horn button assembly, the instrument panel passenger airbag assembly, the front seat airbag assembly or the seat belt pretensioner.
- (7) If the airbag sensor assembly, the side airbag sensor assembly, the horn button assembly, the instrument panel passenger airbag assembly, the front seat airbag assembly or the seat belt pretensioner have been dropped, or if there are cracks, dents or other defects in the case, bracket or connector, replace them with new ones.
- (8) Do not directly expose the airbag sensor assembly, the horn button assembly, the instrument panel passenger airbag assembly, the front seat airbag assembly or the seat belt pretensioner to hot air or flames.
- (9) Use a volt/ohmmeter with high impedance (10 k Ω /V minimum) for troubleshooting of an electrical circuit.
- (10) Information labels are attached to the SRS components. Follow the instructions on the notices.
- (11) After work on the supplemental restraint system is completed, check the SRS warning light (See page 05-424).

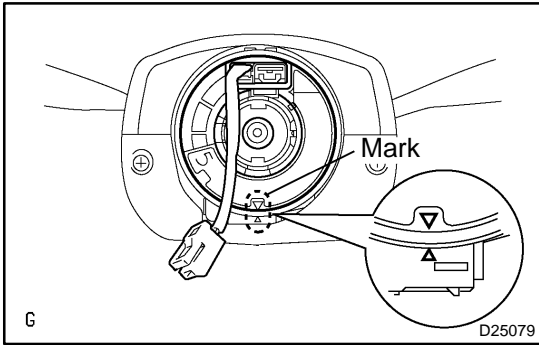

(b) SPIRAL CABLE (in Combination Switch)

- (1) The steering wheel must be fitted correctly to the steering column with the spiral cable at the neutral position, otherwise cable disconnection and other troubles may occur. Refer to page 60-22 on this manual concerning the correct installation of the steering wheel.

(c) HORN BUTTON ASSEMBLY (with Airbag)

- (1) When removing the horn button assembly or handling a new horn button, it should be placed with the pad top surface facing upward. Placing it with the pad surface facing downward may lead to a serious accident if the airbag accidentally inflates. Also, do not place the horn button on top of one another.
- (2) Never measure the resistance of the airbag squib (This may cause the airbag to inflate, which is very dangerous).
- (3) Grease should not be applied to the horn button assembly, and the pad should not be cleaned with detergents of any kinds.
- (4) Store the horn button assembly where the ambient temperature remains below 93°C (200°F), without high humidity and away from electrical noise.
- (5) When using electric welding, first disconnect the airbag connector (4 yellow pins) under the steering column near the combination switch connector before starting work.
- (6) When disposing of the vehicle or the horn button assembly alone, the airbag should be deployed using an SST before disposal (See page 60-14).
Perform the operation in a safe place away from electrical noise.

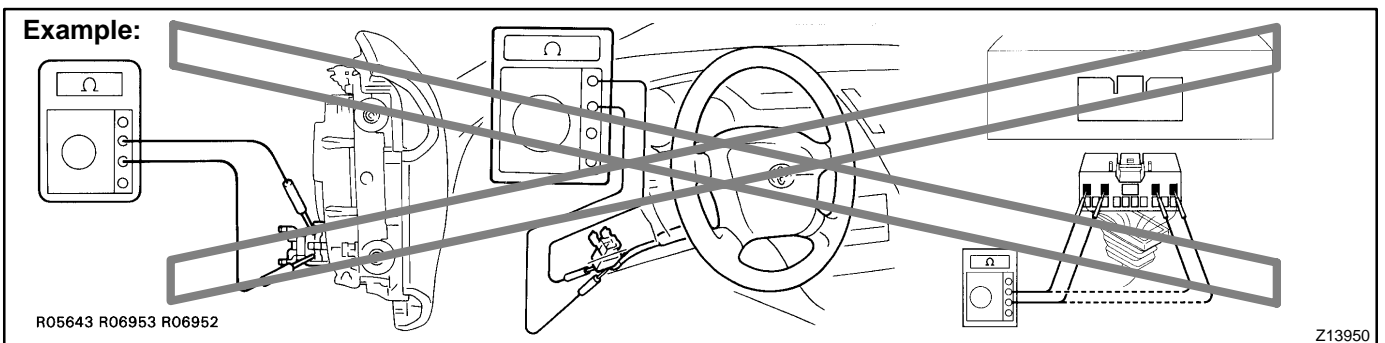
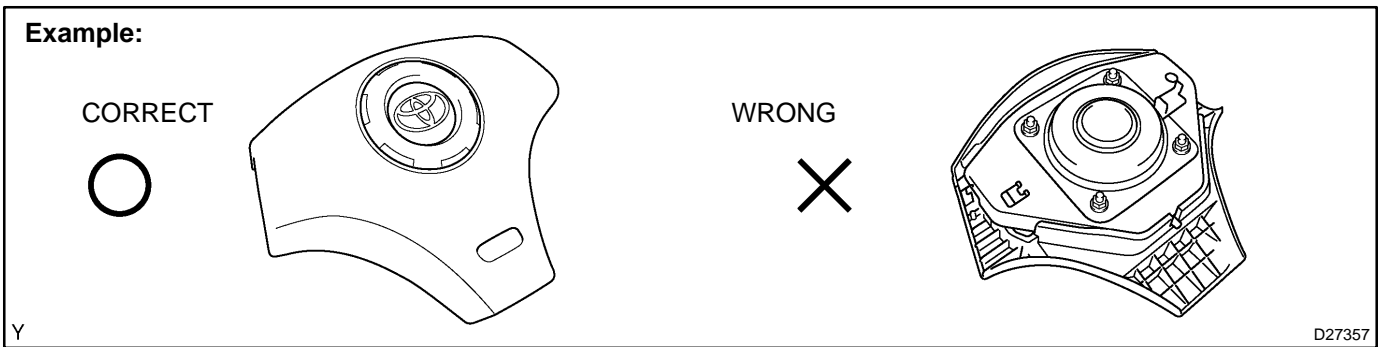

(d) INSTRUMENT PANEL PASSENGER AIRBAG ASSEMBLY

- (1) Always store a removed or new instrument panel passenger airbag assembly with the airbag inflation direction facing upward. Placing the airbag assembly with the airbag inflation direction facing downward could cause a serious accident if the airbag inflates.
- (2) Never measure the resistance of the airbag squib (This may cause the airbag to inflate, which is very dangerous).
- (3) Grease should not be applied to the instrument panel passenger airbag assembly, and the airbag door should not be cleaned with detergents of any kind.
- (4) Store the airbag assembly where the ambient temperature remains below 93°C (200°F), without high humidity and away from electrical noise.
- (5) When using electric welding, first disconnect the airbag connector (4 yellow pins) installed on the assembly before starting work.
- (6) When disposing of a vehicle or the airbag assembly alone, the airbag should be deployed using an SST before disposal (See page 60-26).
Perform the operation in a safe place away from electrical noise.

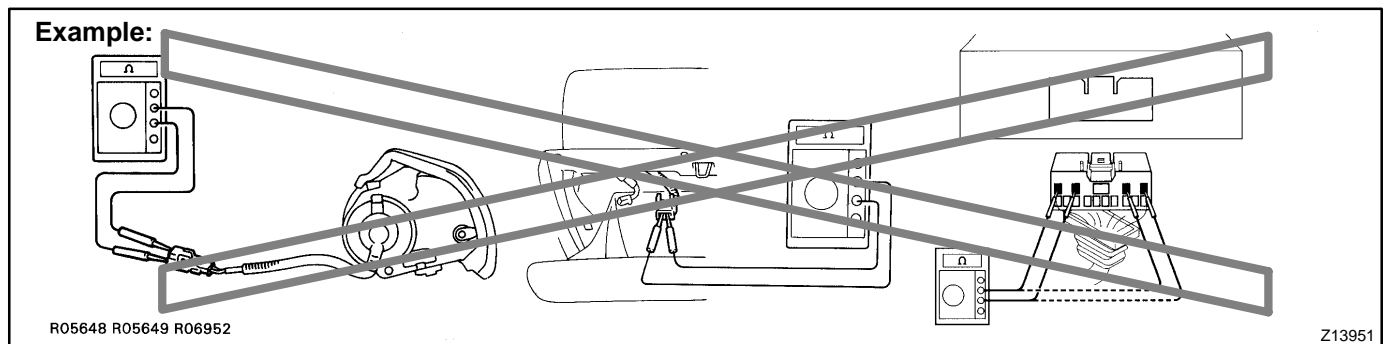
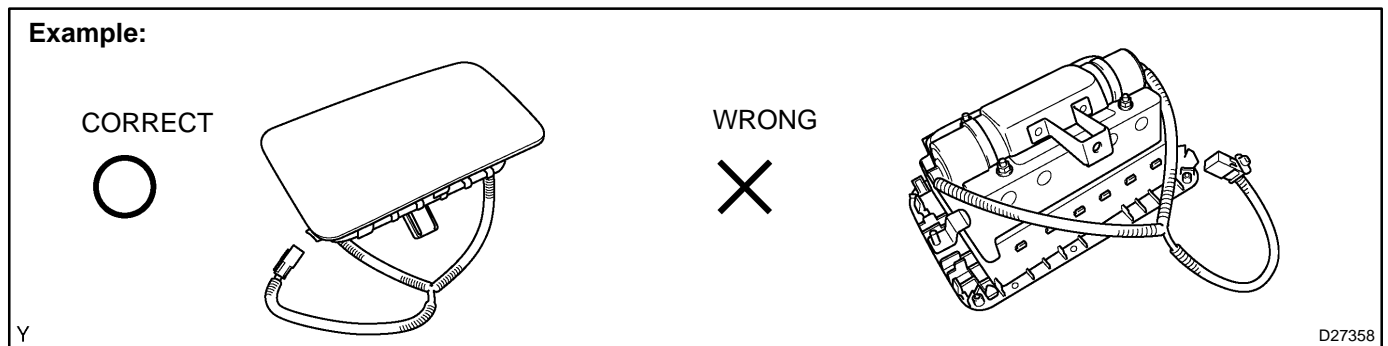

(e) FRONT SEAT AIRBAG ASSEMBLY

- (1) Always store a removed or new front seat airbag assembly with the airbag inflation direction facing upward. Placing the airbag assembly with the airbag inflation direction facing downward could cause a serious accident if the airbag inflates.
- (2) Never measure the resistance of the airbag squib (This may cause the airbag to inflate, which is very dangerous).
- (3) Grease should not be applied to the front seat airbag assembly, and the airbag door should not be cleaned with detergents of any kind.
- (4) Store the airbag assembly where the ambient temperature remains below 93°C (200°F), without high humidity and away from electrical noise.
- (5) When using electric welding, first disconnect the airbag connector (2 yellow pins) installed on the assembly before starting work.

- (6) When disposing of a vehicle or the side airbag assembly alone, the airbag should be deployed using an SST before disposal (See page 60-32).
Perform the operation in a safe place away from electrical noise.

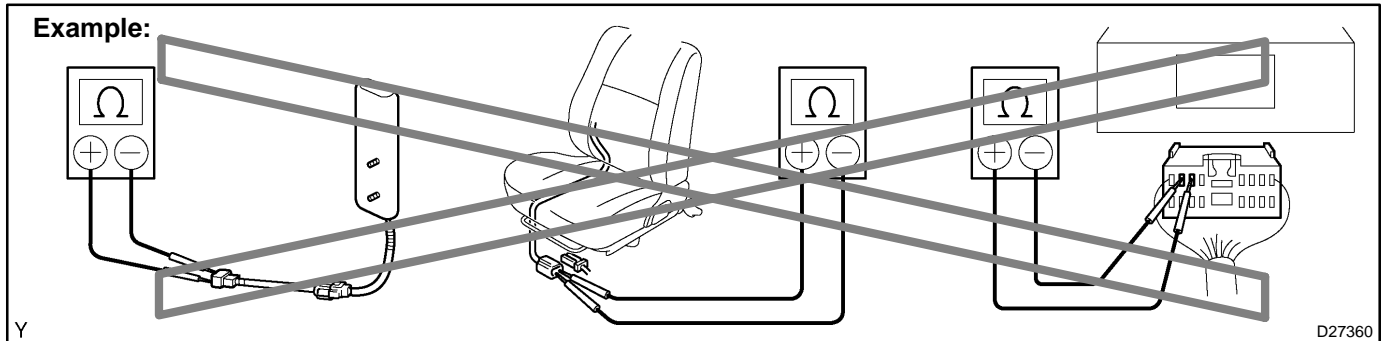

(f) SEAT BELT PRETENSIONER

- (1) Never measure the resistance of the seat belt pretensioner (This may cause the seat belt pretensioner to activate, which is very dangerous).
- (2) Never disassemble the seat belt pretensioner.
- (3) Never install the seat belt pretensioner to another vehicle.
- (4) Store the seat belt pretensioner where the ambient temperature remains below 80°C (176°F) without high humidity and away from electrical noise.
- (5) When using electric welding, first disconnect the connector (2 yellow pins) before starting work.
- (6) When disposing of a vehicle or the seat belt pretensioner alone, the seat belt pretensioner should be activated before disposal (See page 61-9). Perform the operation in a safe place away from electrical noise.
- (7) The seat belt pretensioner is hot after activation, so let it cool down sufficiently before disposal. Never apply water to cool down the seat belt pretensioner.
- (8) Oil or water should not be put on the front seat outer belt, and the front seat outer belt should not be cleaned with detergents of any kind.

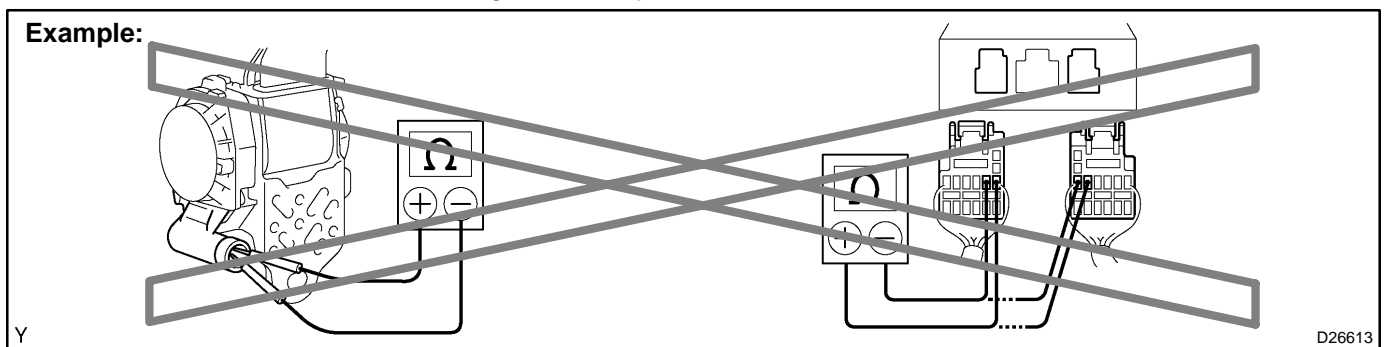

(g) AIRBAG SENSOR ASSEMBLY

- (1) Never reuse the airbag sensor assembly involved in a collision where the SRS has deployed.
- (2) The connectors to the airbag sensor assembly should be connected or disconnected with the sensor mounted on the floor. If the connectors are connected or disconnected while the airbag sensor assembly is not mounted to the floor, it could cause an undesired ignition of the supplemental restraint system.
- (3) Work must be started after 90 seconds from the time the ignition switch is turned to the "LOCK" position and the negative (-) terminal cable is disconnected from the battery, even if only loosening the set bolts of the airbag sensor assembly.

(h) WIRE HARNESS AND CONNECTOR

- (1) The SRS wire harness is integrated with the instrument panel wire harness assembly. All the connectors in the system are in a standard yellow color. If the SRS wire harness becomes disconnected or the connector becomes broken due to an accident, etc., repair or replace it.

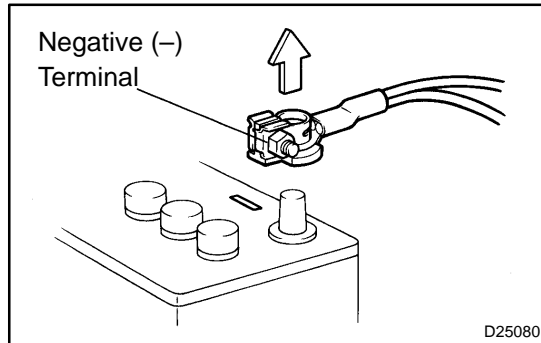
**3. ELECTRONIC CONTROL****(a) REMOVAL AND INSTALLATION OF BATTERY TERMINAL**

- (1) Before performing electrical work, disconnect the battery negative (–) terminal cable beforehand so as to prevent burnt-out damage by short.
- (2) When disconnecting and installing the terminal cable, turn the ignition switch and lighting switch OFF, and loosen the terminal nut completely. Perform these operations without twisting or prying the terminal.
- (3) When the battery terminal is removed, all the memories of the clock, radio, DTCs, etc. will be erased. So before removing it, check them and note them down.

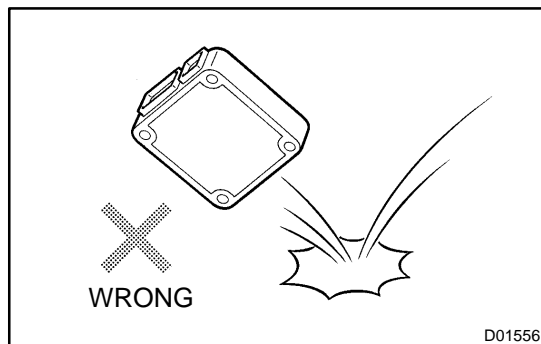
**(b) HANDLING OF ELECTRONIC PARTS**

- (1) Do not open the cover or case of the ECU unless absolutely necessary (If the IC terminals are touched, the IC may be destroyed by static electricity).
- (2) To disconnect electronic connectors, pull the connector itself, not the wires.
- (3) Be careful not to drop electronic components, such as sensors or relays. If they are dropped on a hard floor, they should be replaced and not be reused.
- (4) When cleaning the engine with steam, protect the electronic components, air filter and emission-related components from water.
- (5) Never use an impact wrench to remove or install temperature switches or temperature sensors.
- (6) When checking the continuity at the wire connector, insert the tester probe carefully to prevent terminals from bending.

4. REMOVAL AND INSTALLATION OF FUEL CONTROL PARTS**(a) PLACE FOR REMOVING AND INSTALLING OF FUEL SYSTEM PARTS**

- (1) Work in a place with good air ventilation and without anything flammable such as welder, grinder, drill, electric motor or stove in the surroundings.
- (2) Never work in a place such as a pit or nearby a pit, as there is a possibility that vaporized fuel is filled in those places.

(b) REMOVING AND INSTALLING OF FUEL SYSTEM PARTS

- (1) Prepare a fire extinguisher before starting the operation.
- (2) For prevention of static electricity, install a ground on the fuel changer, vehicle and fuel tank, and do not spray much water so as to prevent slipping.

- (3) Never use any electric equipment like an electric motor or a working light, as they may cause sparks or high temperature.
- (4) Never use an iron hammer, as it may cause sparks.
- (5) Dispose of the shop rag separately from any fuel deposit.

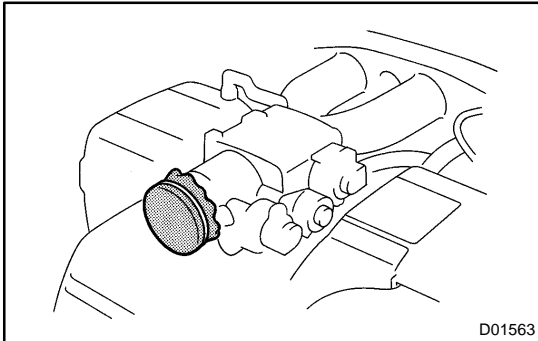

5. REMOVAL AND INSTALLATION OF ENGINE INTAKE PARTS

- (a) If any metal tip is mixed in the inlet pass, this may give a bad effect to the engine and turbocharger.
- (b) When removing and installing the inlet system parts, close the opening of the removed inlet system parts and the engine with a clean shop rag or gummed tape.
- (c) When installing the inlet system parts, check that there is no mixing of a metal tip.

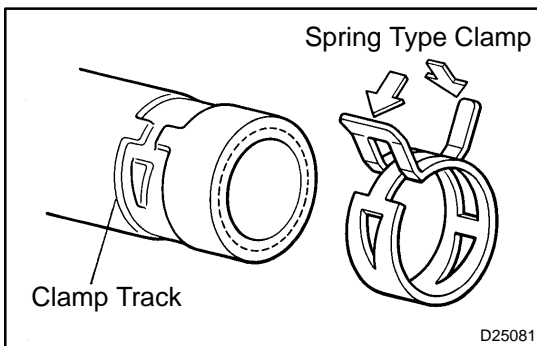

6. HANDLING OF HOSE CLAMPS

- (a) Before removing the hose, check the depth of the inserting portion and the clamp position in order to restore it surely.
- (b) Change a deformed or dented clamp for a new one.
- (c) In case of reusing the hose, install the clamp on the hose where it has a clamp track.
- (d) For a spring type clamp, adjust it by adding force to the arrow mark direction after the installation.

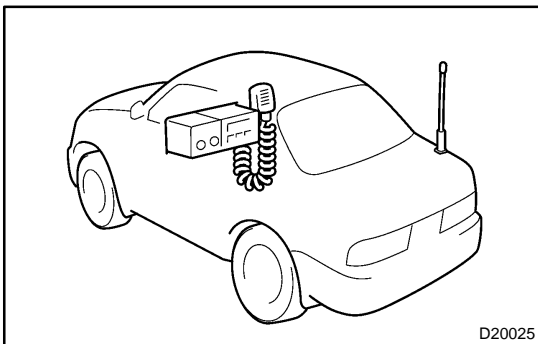

7. FOR VEHICLES EQUIPPED WITH MOBILE COMMUNICATION SYSTEM

- (a) Install an antenna as far as possible away from the ECU and sensors of the vehicle's electronic systems.
- (b) Install an antenna feeder at least 20 cm (7.87 in.) away from the ECU and sensors of the vehicle's electronic systems. For details of the ECU and sensors locations, refer to the section on the applicable component.
- (c) Prevent the antenna feeder from getting entangled with the other wirings, and keep the antenna feeder separately from the other wirings as much as possible.
- (d) Check that the antenna and feeder are correctly adjusted.
- (e) Do not install any powerful mobile communication system.

8. FOR VEHICLES EQUIPPED WITH CATALYTIC CONVERTER**CAUTION:**

If large amount of unburned fuel flows into the converter, it may cause overheating and a fire hazard.

To prevent this, observe the following precautions.

- (a) Use only unleaded gasoline.
- (b) Avoid prolonged idling.
Avoid running the engine at idle speed for more than 20 minutes.
- (c) Avoid a spark jump test.
 - (1) Perform a spark jump test only when absolutely necessary. Perform this test as rapidly as possible.
 - (2) While testing, never race the engine.
- (d) Avoid a prolonged engine compression measurement.
Engine compression measurements must be performed as rapidly as possible.
- (e) Do not run the engine when the fuel tank is nearly empty. This may cause the engine to misfire and create an extra load on the converter.

VEHICLE LIFT AND SUPPORT LOCATIONS

1. NOTICE ABOUT VEHICLE CONDITION WHEN JACKING UP

- (a) As a rule, the vehicle must be unloaded when jacking up. Never jack up or lift up the vehicle loaded with things of heavy weight.
- (b) When removing any parts of heavy weight like the engine and transmission, the center of gravity of the vehicle moves. Place a balance weight so as to keep it from rolling, or hold the jacking support location using the mission jack.

2. NOTICE FOR USING 4 POST LIFT

- (a) Follow the instruction manual for a safety operation.
- (b) Do not damage tires or wheels with a free wheel beam.
- (c) Using a wheel stopper, fix the vehicle.

3. NOTICE FOR USING JACK AND SAFETY STAND

- (a) Work in a flat place using a wheel stopper at all times.

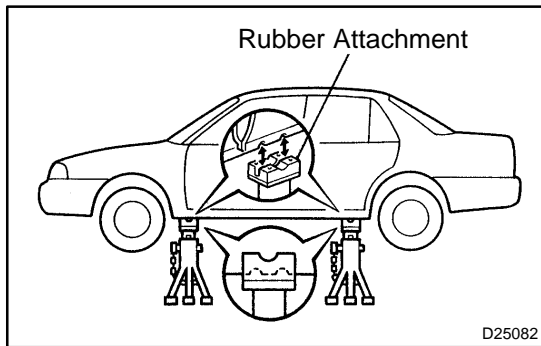

- (b) Use a safety stand with a rubber attachment, as shown in the illustration.
- (c) Support the specified location with a jack and safety stand accurately.
- (d) When jacking up the front wheels, release the parking brake and place wheel stoppers only behind the rear wheels. When jacking up the rear wheels, place wheel stoppers only in front of the front wheels.
- (e) Do not work or leave the vehicle supported only by a jack. Be sure to support the vehicle with a safety stand.

- (f) When jacking up only the front wheels or only the rear wheels, place wheel stoppers to both sides of the wheels that contact ground.
- (g) When jacking down the vehicle with its front wheels jacked up, release the parking brake and place wheel stoppers only in front of the rear wheels. When jacking down the vehicle with its rear wheels jacked up, place wheel stoppers only behind the front wheels.

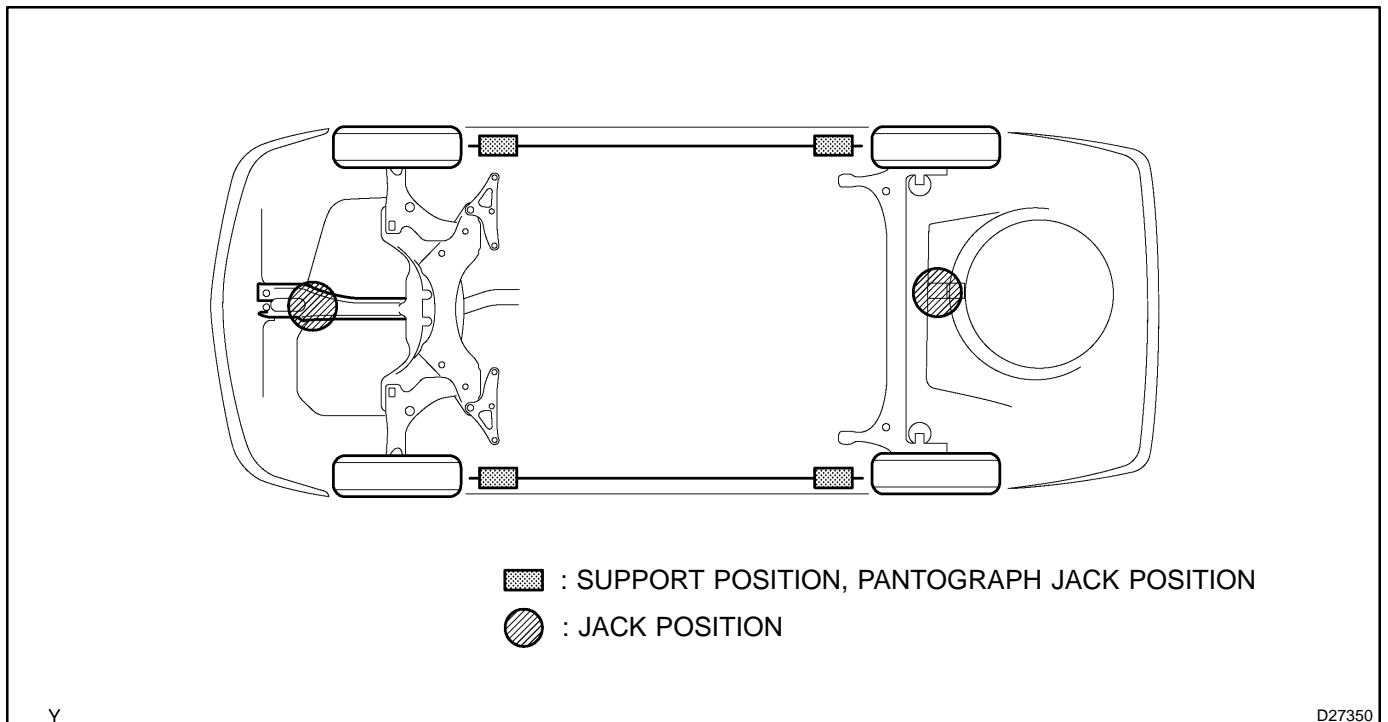

4. NOTICE FOR USING SWING ARM TYPE LIFT

- (a) Follow the instruction manual of the lift for a safe operation.
- (b) Use a cradle with a rubber attachment, as shown in the illustration.
- (c) Set in the vehicle so as to make its center of gravity as close as possible to the center of the lift. ("L" becomes short.)
- (d) Place the vehicle horizontally by adjusting the height of the cradle, and match the groove of the cradle and the safety stand support location accurately.
- (e) Be sure to lock the swing arm during the operation.
- (f) Lift the vehicle up until the tires float, and shake the vehicle to make sure that the vehicle is stable.

5. NOTICE FOR USING PLATE TYPE LIFT

- (a) Follow the instruction manual of the lift for a safe operation.
- (b) Use a plate lift attachment.
- (c) Be sure to set the vehicle to the specified position.

Right and left set position	• Place the vehicle over the center of the lift.
Front and rear set position	• Align the cushion gum ends of the plate with the attachment lower ends (A and C). • Align the attachment upper end (B) with the rocker flange front side notch.

- (d) Lift the vehicle up until the tires float a bit, and shake the vehicle to make sure that the vehicle is stable.

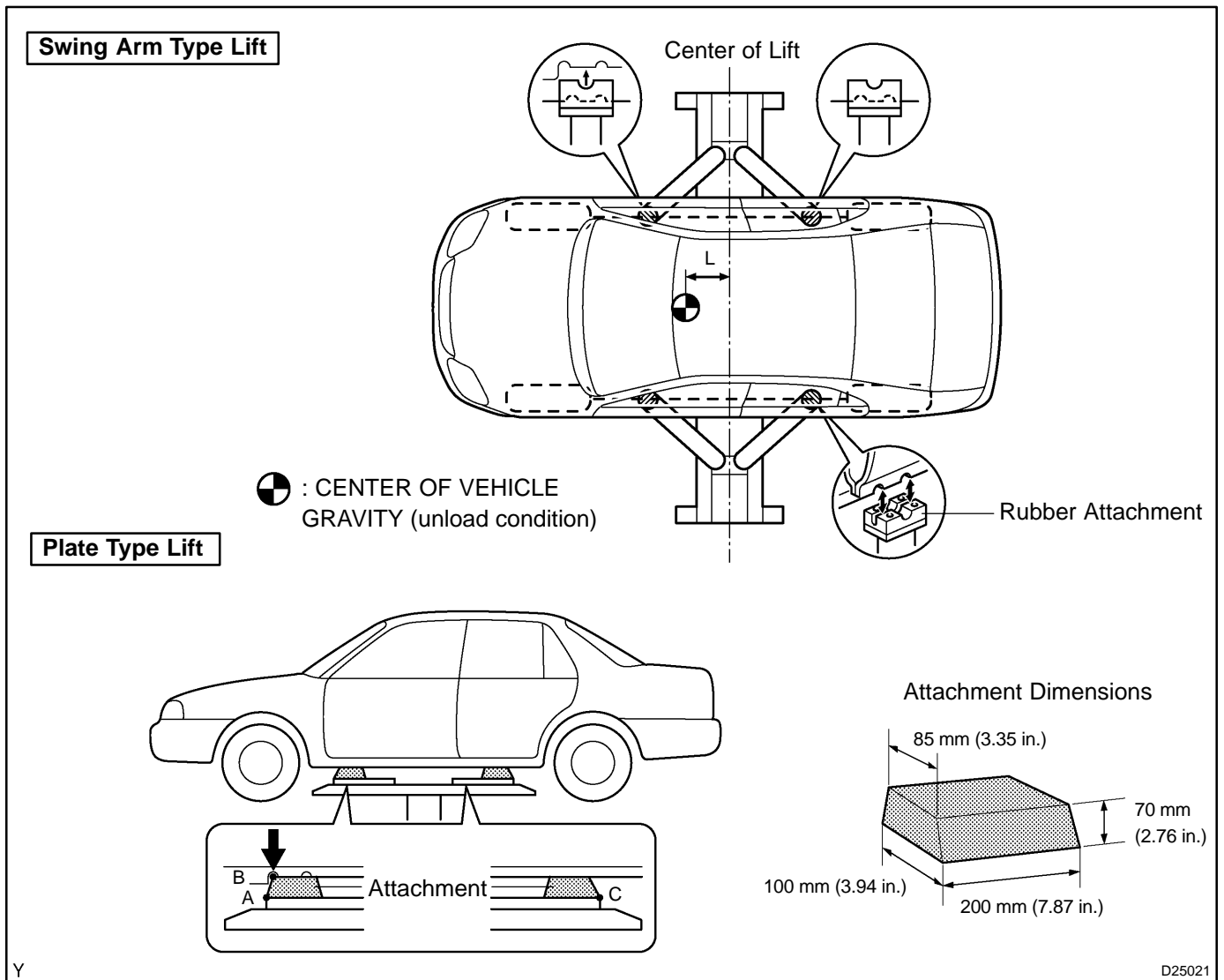

Y

D25021

HOW TO TROUBLESHOOT ECU CONTROLLED SYSTEMS

GENERAL INFORMATION

01034-08

There are many ECU controlled systems used in the COROLLA. In general, ECU controlled systems are considered to be very intricate and require a high level of technical knowledge and expert skill to troubleshoot. The fact is, however, that if you proceed by inspecting the circuits one by one, troubleshooting of these systems is not complex. If you have adequate understanding of the system and basic knowledge of electricity, the problem can be accurately diagnosed and fixed. This manual is designed based on the above principle to help service technicians perform accurate and effective troubleshooting, and is compiled for the following major ECU controlled systems:

The troubleshooting procedures are described on the following pages.

System	Page
1. SFI System	05-1
2. ABS with EBD System	05-294
3. Electronic Controlled Automatic Transaxle [ECT]	05-346
4. Supplemental Restraint System	05-421
5. Audio System	05-596
6. Combination Meter	05-638
7. Power Door Lock Control System	05-670
8. Wireless Door Lock Control System	05-685
9. TOYOTA Vehicle Intrusion Protection System	05-700
10. Cruise Control System	05-742

FOR USING HAND-HELD TESTER

- Before using the tester, the tester's operator manual should be read thoroughly.
- If the tester cannot communicate with the ECU controlled systems when you have connected the cable of tester to the DLC3, turned the ignition switch ON and operated the tester, there is a problem on the vehicle side or tester side.
 - (1) If the communication is normal when the tester is connected to another vehicle, inspect the diagnosis data link line (Bus \oplus line) or ECU power circuit of the vehicle.
 - (2) If the communication is still impossible when the tester is connected to another vehicle, the problem is probably in the tester itself, so perform the Self Test procedures outlined in the Tester Operator's Manual.

HOW TO PROCEED WITH TROUBLESHOOTING

HINT:

Carry out troubleshooting in accordance with the procedures on the following page. Here, only the basic procedures are shown. Details are provided in the Diagnostics Section, showing the most effective methods for each circuit. Confirm the troubleshooting procedures first for the relevant circuit before beginning troubleshooting of that circuit.

1 Vehicle brought to workshop



2 Customer problem analysis

- (a) Ask the customer about the conditions and environment when the problem occurred.



3 Symptom confirmation and DTC (and freeze frame data) check

- (a) Check the battery positive voltage.
Voltage: 11 – 14 V (Engine stopped)
- (b) Visually check the wire harness, connectors and fuses for open and short, etc.
- (c) Warm up the engine to the normal operating temperature.
- (d) Confirm the problem symptoms and conditions, and check for DTCs according to the related chart.

OK

Go to step 5

NG

4 DTC chart

- (a) Check the results obtained in step 3, then confirm the inspection procedures for the system or the part which should be checked using the DTC chart.



Go to step 6

5 Problem symptoms chart

- (a) Check the results obtained in step 3, then confirm the inspection procedures for the system or the part which should be checked using the problem symptoms table.



6 Circuit inspection or parts inspection

- (a) Confirm the circuit for the system or the part which should be checked using the problem symptoms table or the results obtained in step 4.



7 Repair

- (a) Repair the affected system or part in accordance with the instructions in step 6.



8	Confirmation test
----------	--------------------------

- (a) After completing repairs, confirm that the problem has been solved (If the problem does not recur, perform a confirmation test under the same conditions and in the same environment as when it occurred for the first time).

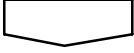

END

CUSTOMER PROBLEM ANALYSIS

HINT:

- In troubleshooting, the problem symptoms must be confirmed accurately, meaning that all preconceptions must be set aside in order to make an accurate judgement. To ascertain what the problem symptoms are, it is extremely important to ask the customer about the problem and conditions when it occurred.
- The following 5 items are important points in the problem analysis. Past problems which are thought to be unrelated and the repair history, etc. may also help in some cases. Therefore, as much information as possible should be gathered and its relationship with the problem symptoms should be correctly ascertained for use as reference in troubleshooting. A customer problem analysis table is provided for your use in the Diagnostics Section for each system.

Important Points with Customer Problem Analysis

- What ——— Vehicle model, system name
- When ——— Date, time, occurrence frequency
- Where ——— Road conditions
- Under what conditions? ——— Running conditions, driving conditions, weather conditions
- How did it happen? ——— Problem symptoms

(Sample) Supplemental restraint system check sheet.

CUSTOMER PROBLEM ANALYSIS CHECK			
Supplemental Restraint System Check Sheet		Inspector's Name	
Customer's Name	VIN		
	Production Date		/ /
	Licence No.		
Date Vehicle Brought In	/ /	Odometer Reading	km miles
Date Problem First Occurred	/ /		
Weather	<input type="checkbox"/> Fine <input type="checkbox"/> Cloudy <input type="checkbox"/> Rainy <input type="checkbox"/> Snowy <input type="checkbox"/> Other		
Temperature	Approx.		
Vehicle Operation	<input type="checkbox"/> Starting <input type="checkbox"/> Idling <input type="checkbox"/> Driving [<input type="checkbox"/> Constant speed <input type="checkbox"/> Acceleration <input type="checkbox"/> Deceleration] <input type="checkbox"/> Other		

SYMPTOM CONFIRMATION AND DIAGNOSTIC TROUBLE CODE

HINT:

- The diagnostic system in COROLLA has various functions. The first function is the Diagnostic Trouble Code (DTC) Check, in which a malfunction in the signal circuits to the ECU is stored in code form in the ECU memory. Another function is the Input Signal Check, which checks if the signals from various switches are sent to the ECU correctly. By using these check functions, it is possible to quickly narrow down potential problem areas and troubleshooting can be performed effectively. The diagnostic functions are incorporated in the following systems in the COROLLA.

System	Diagnostic Trouble Code Check	Input Signal Check (Sensor Check)	Diagnostic Test Mode (Active Test)
SFI System	☑ (with Check Mode)	☑	☑
ABS with EBD System	☑	☑	
Electronic Controlled Automatic Transaxle [ECT]	☑ (with Check Mode)	☑	
Supplemental Restraint System	☑		
Cruise Control System		☑	

- In the DTC check, it is very important to determine whether the problem indicated by the DTC is still occurring or has occurred in the past but returned to normal at present. In addition during the problem symptom check, it a check must be made on whether the malfunction indicated by the DTC is directly related to the problem symptom or not. For this reason, the DTC should be checked before and after symptom confirmation to determine the current conditions. If this is not done, it may, depending on the case, result in unnecessary troubleshooting for systems that are operating normally. This would make more difficult to detect the problem area or to try to repair irrelevant areas. Therefore, always follow the procedures in the correct order and perform the DTC check.
- A flow chart showing how to proceed with troubleshooting using the diagnostic trouble code (DTC) check is shown the this page. This flow chart shows how to utilize the DTC check effectively. Then, by carefully checking the results, this chart indicates how to proceed either to the DTC troubleshooting or to the troubleshooting of the problem symptoms table.

1 DTC check



2 Making a note and clear the DTCs



3 Symptom confirmation

☑	Problem symptoms exist
☑	No problem symptoms exist

a Go to step 5

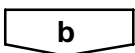

4 Simulation test using the symptom simulation methods



5 DTC check

②	DTC displayed
②	Normal code displayed

a Troubleshooting of problem indicated by DTC

b

6 Symptom confirmation

②	No problem symptoms exist
②	Problem symptoms exist

If a DTC is displayed in the initial DTC check, it indicates that a trouble may have occurred in a wire harness or connector in that circuit in the past, therefore check the wire harness and connectors (See page 01-30).

a System normal

b

Troubleshooting of each problem symptom

The problem is still occurring in a place other than the diagnostic circuit (The DTC displayed first is either for a past problem or it is a secondary problem).

SYMPTOM SIMULATION

HINT:

The most difficult case in troubleshooting is when no symptoms occurs. In such cases, a thorough customer problem analysis must be carried out. Then the same or similar conditions and environment in which the problem occurred in the customer's vehicle should be simulated. No matter how much experience a technician has, or how skilled he may be, if he proceeds to troubleshoot without confirming the problem symptoms, he will tend to overlook something important in the repair operation and make a wrong guess somewhere, which will only lead to a standstill. For example, for a problem which only occurs when the engine is cold, or for a problem which occurs due to vibration caused by the road during driving, etc., the problem can never be determined when the engine is hot or when the vehicles is at a standstill. Since vibration, heat or water penetration (moisture) is a likely cause for the problem which is difficult to reproduce, the symptom simulation tests introduced here are effective measures in a point that the external causes are applied to the vehicle in a stationary condition.

Important points in the symptom simulation test:

In the symptom simulation test, the problem symptoms should be confirmed, and the problem area or parts must also be discovered. To do so, reduce the possible problem circuits according to the symptoms before starting this type of test and have the hand-held tester connected beforehand. After that, carry out the symptom simulation test, judging whether the circuit being tested is defective or normal and also confirming the problem symptoms at the same time. Refer to the problem symptoms table of each system to narrow down the possible causes of the symptom.

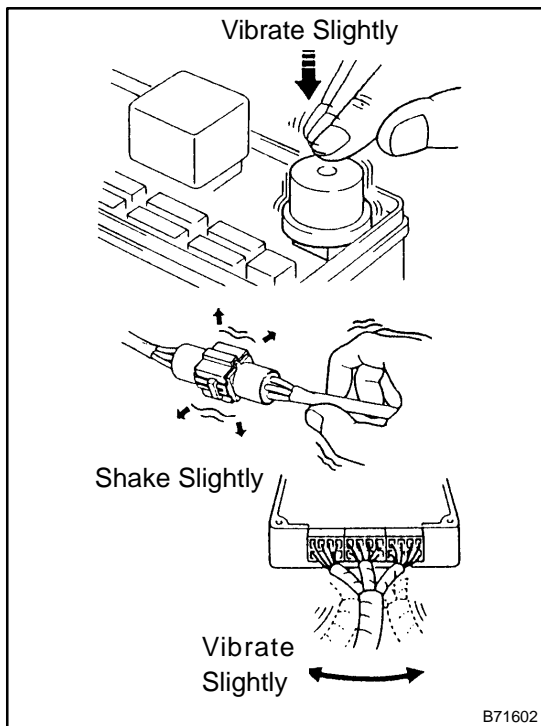

1. VIBRATION METHOD: When vibration seems to be the major cause.

- (a) PART AND SENSOR
 - (1) Apply slight vibration with your finger to the part of the sensor considered to be the problem cause and check whether the malfunction occurs.

HINT:

Applying strong vibration to relays may result in open relays.

- (b) CONNECTORS
 - (1) Slightly shake the connector vertically and horizontally.
- (c) WIRE HARNESS
 - (1) Slightly shake the wire harness vertically and horizontally.

The connector joint and fulcrum of the vibration are the major areas that should be checked thoroughly.

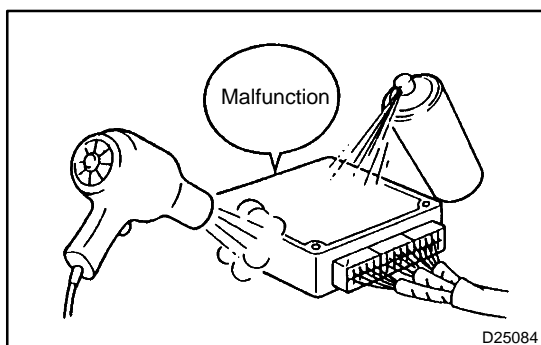

2. HEAT METHOD: If the problem seems to occur when the area in question is heated.

- (a) Heat the component that is the possible cause of the malfunction with a hair dryer or similar object. Check if the malfunction occurs.

NOTICE:

- Do not heat the components to more than 60 °C (140 °F) (Temperature is limited to keep the components from being damaged).

- Do not apply heat directly to the parts in the ECU.

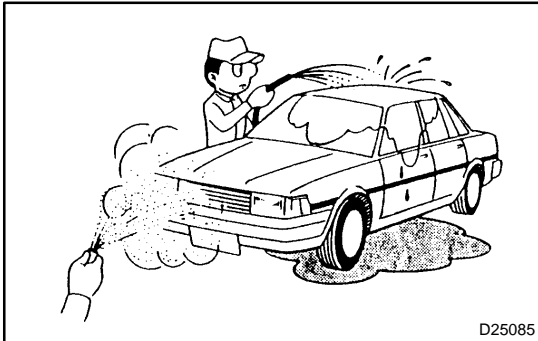

3. **WATER SPRINKLING METHOD:** When the malfunction seems to occur on a rainy day or in high-humidity.
 - (a) Sprinkle water onto the vehicle and check if the malfunction occurs.

NOTICE:

- Never sprinkle water directly onto the engine compartment, but indirectly change the temperature and humidity by spraying a mist of water onto the radiator front surface.
- Never apply water directly onto the electronic components.

HINT:

If a vehicle is subject to water leakage, the leaking water may contaminate the ECU. When testing a vehicle with a water leakage problem, this factor must also be considered.

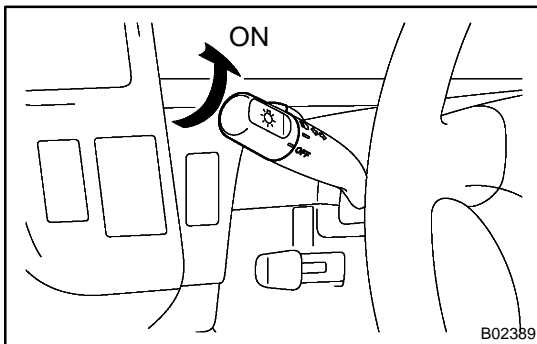

4. **OTHERS:** If the malfunction seems to occur when electrical load is excessive.
 - (a) Turn on all the electrical equipment including the heater blower, headlights, rear window defogger, etc., and check if the malfunction occurs.

DIAGNOSTIC TROUBLE CODE CHART

The inspection procedures are shown in the table below. This table allows efficient and accurate troubleshooting using the diagnostic trouble codes displayed in the diagnostic trouble code chart. Proceed with troubleshooting in accordance with the inspection procedures listed in the diagnostic chart corresponding to the diagnostic trouble codes displayed. The diagnostic trouble code chart for the Supplemental Restraint System is shown below as an example.

- DTC No.
Indicates the diagnostic trouble code.
- Page or Instructions
Indicates the page where the inspection procedures for each circuit is to be found, or gives instructions for checking and repairs.

- Trouble Area
Indicates the suspect areas of the problem.

- Detection Item
Indicates the system or details of the problem.

DIAGNOSTIC TROUBLE CODE CHART
If a malfunction code is displayed during the DTC check, check the circuit for that code listed in the table below (Proceed to the page given for that circuit).

DTC No. (See page)	Detection Item	Trouble Area	SRS Warning Light
B0100/13 (05-119)	● Short in D squib circuit	<ul style="list-style-type: none"> ● Steering wheel pad (squib) ● Spiral cable ● Airbag sensor assembly ● Wire harness 	ON
B0101/14 (05-124)	● Open in D squib circuit	<ul style="list-style-type: none"> ● Steering wheel pad (squib) ● Spiral cable ● Airbag sensor assembly ● Wire harness 	ON
B0102/11 (05-128)	● Short in D squib circuit (to ground)	<ul style="list-style-type: none"> ● Steering wheel pad (squib) ● Spiral cable ● Airbag sensor assembly ● Wire harness 	ON
B0103/12 (05-132)	● Short in D squib circuit (to B+)	<ul style="list-style-type: none"> ● Steering wheel pad (squib) ● Spiral cable ● Airbag sensor assembly ● Wire harness 	ON
B0105/53 (05-136)	● Short in P squib circuit	<ul style="list-style-type: none"> ● Front passenger airbag assembly (squib) ● Airbag sensor assembly ● Wire harness 	ON
B0106/54	● Open in P squib circuit	<ul style="list-style-type: none"> ● Front passenger airbag assembly (squib) ● Airbag sensor assembly ● Wire harness 	
	● Short in P squib circuit (to Ground)	<ul style="list-style-type: none"> ● Front passenger airbag assembly (squib) ● Airbag sensor assembly ● Wire harness 	

PROBLEM SYMPTOMS TABLE

The suspected circuits or parts for each problem symptom are shown in the table below. Use this table to troubleshoot the problem when a Normal code is displayed in the diagnostic trouble code chart but the problem is still occurring. Numbers in the table indicate the order in which the circuits or parts should be checked. HINT:

When the problem is not detected by the diagnostic system even though the problem symptom is present, it may be that the problem is occurring outside the detection range of the diagnostic system.

● Page
Indicates the page where the flow chart for each circuit is located.

● Circuit Inspection, Inspection Order
Indicates the circuit which needs to be checked for each problem symptom. Check in the order indicated by the numbers.

● Problem Symptom

● Circuit or Part Name
Indicates the circuit or part which needs to be checked.

PROBLEM SYMPTOMS TABLE
Proceed with troubleshooting of each circuit in the table below.

Symptom	Suspected Area	See page
1. With the ignition switch in ACC or ON position, the SRS warning light sometimes lights up after approx. 6 seconds have elapsed. 2. SRS warning light is always lit up even when ignition switch is in the LOCK position	1. SRS warning light circuit (Always lights up when ignition switch is in LOCK position.)	05-180
1. With the ignition switch in the ACC or ON position, the SRS warning light does not light up.	1. SRS warning light circuit (Does not light up when ignition switch is turned to ACC or ON.)	05-183
1. DTC is not displayed. 2. SRS warning light is always lit up at the time of DTC check procedure. 3. DTC is displayed without Tc and CG terminal connection.	1. Tc terminal circuit	05-187

CIRCUIT INSPECTION

How to read and use each page is shown below.

● Circuit Description

The major role and, operation of the circuit and its component parts are explained.

● Diagnostic Trouble Code No. and Detection Item

● Indicates the diagnostic trouble codes, diagnostic trouble code settings and suspect areas for a problem.

● Inspection Procedures

Use the inspection procedures to determine if the circuit is normal or abnormal. If it is abnormal, use it to determine whether the problem is located in the sensors, actuators, wire harness or ECU.

05-178 DIAGNOSTICS - SEI SYSTEM (1ZZ-FE) **DTC P0500/42 VEHICLE SPEED SENSOR MALFUNCTION**

CIRCUIT DESCRIPTION

The vehicle speed sensor outputs a 4-pulse signal for every revolution of the rotor shaft, which is rotated by the transmission output shaft via the driven gear. After this signal is converted into a more precise rectangular waveform by the waveform shaping circuit inside the combination meter, it is then transmitted to the Engine ECU. The Engine ECU determines the vehicle speed based on the frequency of these pulse signals.

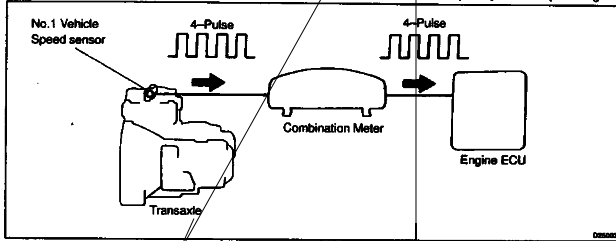

DTC No.	DTC Detecting Condition	Trouble Area
P0500/42	During vehicle is being driven, no vehicle speed sensor signal to engine ECU (2 trip detection logic)	<ul style="list-style-type: none"> • Combination meter • Open or short in No. 1 vehicle speed sensor circuit • No. 1 vehicle speed sensor • Engine ECU

WIRING DIAGRAM

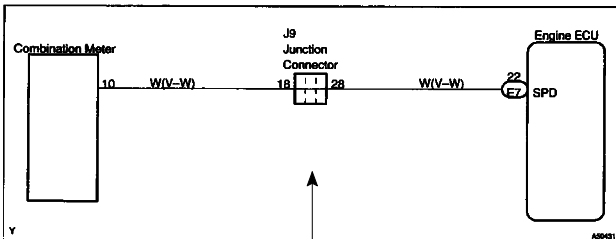

● Wiring Diagram

This shows a wiring diagram of the circuit. Use this diagram together with ELECTRICAL WIRING DIAGRAM to thoroughly understand the circuit.

Wire colors are indicated by an alphabetical code. B = Black, L = Blue, R = Red, BR = Brown, LG = Light Green, V = Violet, G = Green, O = Orange, W = White, GR = Gray, P = Pink, Y = Yellow, SB = Sky Blue. The first letter indicates the basic wire color and the second letter indicates the color of the stripe.

INSPECTION PROCEDURE

1 READ VALUE OF VEHICLE SPEED VALUE(SPEEDOMETER OPERATION)

- (a) Select data monitor on the hand-held tester.
- (b) Perform a test drive of the vehicle.
- (c) Read the vehicle speed on the hand-held tester.

RESULT: The same as the speed displayed on the speed meter.

NG → REPLACE COMBINATION METER ASSY

OK

2 INSPECT ECU

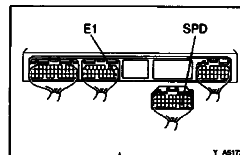

(a) Check the output waveform.
HINT: Using the oscilloscope function of hand-held tester, it is possible to check the function between the engine ECU and the knock control sensor. The waveform shown in the illustration is an example without noise and chattering.

- (1) Connect the hand-held tester between the terminals SPD of the engine ECU E7 connector and E1 of the engine ECU E8 connector.
- (2) Select the oscilloscope function on the hand-held tester. (Refer to the hand-held tester's instruction book for operating instructions.)

RESULT: Voltage is intermittently generated.

ITEM	CONTENTS
TERMINAL	SPD↔E1
EQUIPMENT SET	5V/DIV, 20ms/DIV
CONDITION	Running at 20 km/h

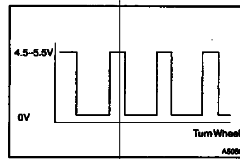

HINT:
 • The multitude gets shorter as the engine speed becomes faster.

OK → CHECK AND REPLACE ECU

NG

● Indicates the condition of the connector of the ECU during the check.

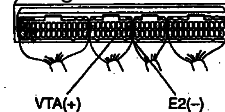

Connector being checked is connected.

Connections of tester are indicated by (+), (-) after terminals name.

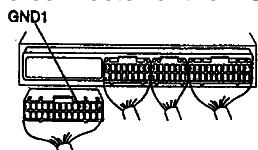

Connector being checked is disconnected.

For inspection of connector with body ground, there is nothing about the body ground written down.

ELECTRONIC CIRCUIT INSPECTION PROCEDURE

1. BASIC INSPECTION

(a) RESISTANCE MEASURING CONDITION OF ELECTRONIC PARTS

- (1) Unless stated, all resistance is measured at an ambient temperature of 20°C (68°F). As the resistance may be outside the specifications if measured at high temperatures immediately after the vehicle has been running, measurements should be made when the engine has cooled down.

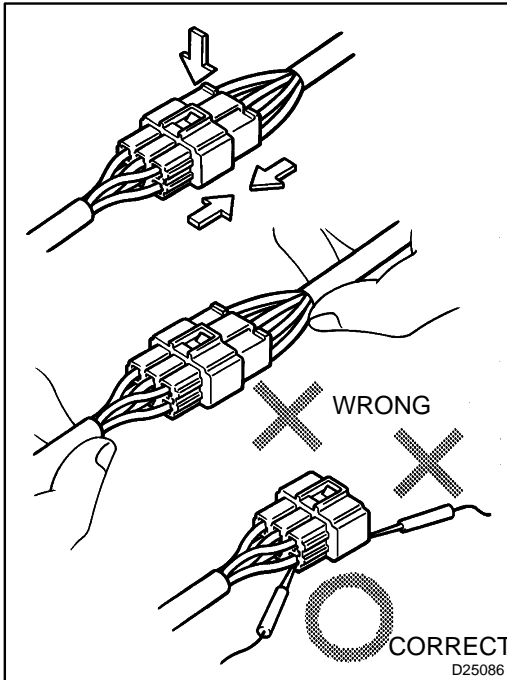

(b) HANDLING OF CONNECTOR

- (1) When removing the connector with lock, press the connector in the direction of the engagement and remove the lock by lightly pressing the lock claw.
- (2) When removing the connector, do not hold the harness, but hold the connector.
- (3) Before connecting the connector, check that there is no deformation, damage or missing terminals.
- (4) The connector with a lock should be securely connected until it makes a "click" sound.
- (5) When checking the connector with a Toyota electrical tester, check it from the backside (harness side) of the connector using a mini test lead.

NOTICE:

- As a water proof connector cannot be checked from the backside, check by connecting the sub-harness.
- Do not damage the terminals by moving the inserted tester needle.

(c) CONNECTOR CHECKING POINTS

- (1) Checking when the connector is connected:

By holding the connector, check the inserted condition and locking efficiency (engaged condition).
- (2) Checking when the connector is removed:

Check by lightly pulling the wire harness (missing terminal, terminal crimping condition, core wire break).
Check visually for any rust, metal particles, water and bent terminals (rust, mixing of foreign object, terminal deformation).

NOTICE:

When testing a gold-plated female terminal, always use a gold-plated male terminal.

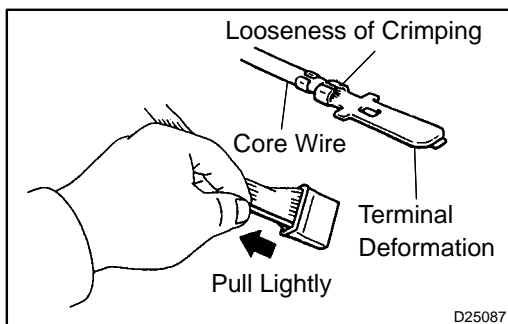

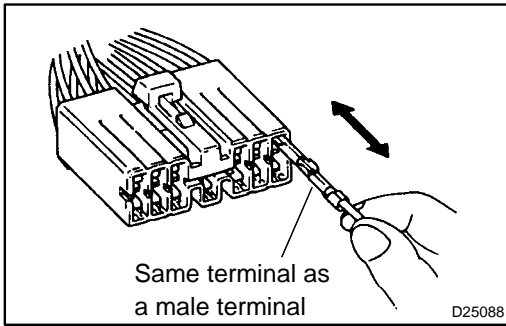

- (3) Checking of the contact pressure of the terminal:
Prepare a spare male terminal.
Insert it into a female terminal, check the engaged condition and sliding resistance.

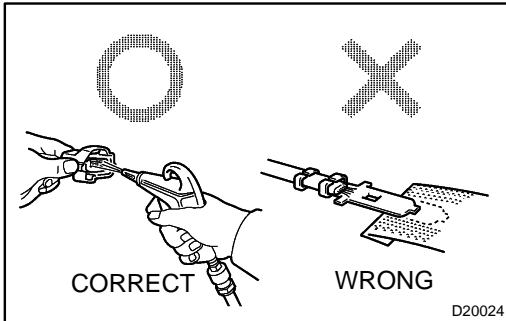

(d) REPAIR METHOD OF CONNECTOR TERMINAL

- (1) If there is on the contact point, clean the contact point using an air gun or shop rag. However, never polish the contact point using sand paper as the platings may come off.
- (2) In case of abnormal contact pressure, replace the female terminal. However, if a male terminal is gold-plated (gold color), use gold-plated female terminal and if it is silver-plated (silver color), use silver-plated female terminal.

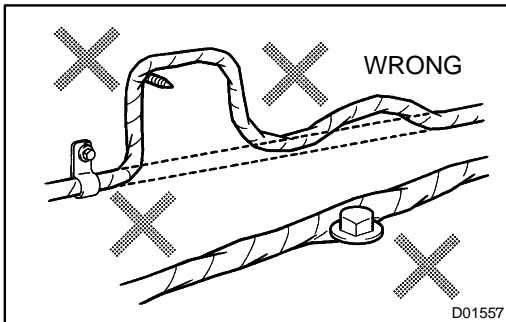

(e) HANDLING OF WIRE HARNESS

- (1) When removing the wire harness, check the positioning of the wiring and clamping before starting work in order to be able to restore it correctly.
- (2) Never twist, pull or loosen the wire harness more than necessary.
- (3) Never allow the wire harness to come into contact with a high-temperature, rotating, moving, vibrating or sharp (edge of the panel, tip of the screw, etc.) part.
- (4) When installing parts, never let the wire harness be interfered with.
- (5) Never cut or break the cover of the wire harness. If one is cut or broken, replace it or securely repair it with electrical tape.

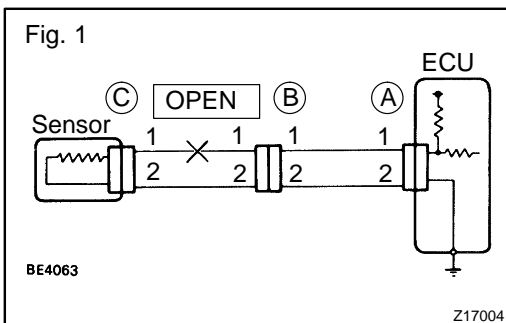

2. CHECK OPEN CIRCUIT

- (a) For the open circuit in the wire harness in Fig. 1, perform a resistance check in step (b) or a voltage check in step (c) to locate the section.

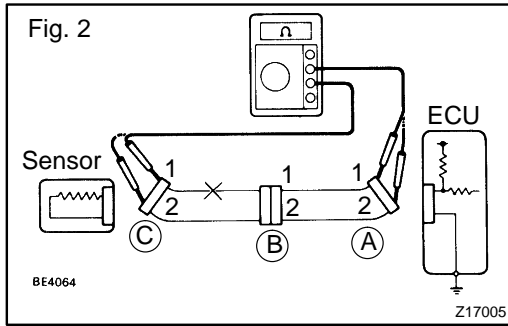

- (b) Check the resistance.
 (1) Disconnect connectors A and C and measure the resistance between them.

Resistance: 1 Ω or less

HINT:

Measure the resistance while lightly shaking the wire harness vertically and horizontally.

In the case of Fig. 2:

Between terminal 1 of connector A and terminal 1 of connector C → 10 KΩ or higher

Between terminal 2 of connector A and terminal 2 of connector C → Below 1 Ω

Therefore, the cause is an open circuit between terminal 1 of connector A and terminal 1 of connector C.

- (2) Disconnect connector B and measure the resistance between the connectors.

In the case of Fig. 3:

Between terminal 1 of connector A and terminal 1 of connector B1 → Below 1 Ω

Between terminal 1 of connector B2 and terminal 1 of connector C → 10 KΩ

Therefore, the cause is an open circuit between terminal 1 of connector B2 and terminal 1 of connector C.

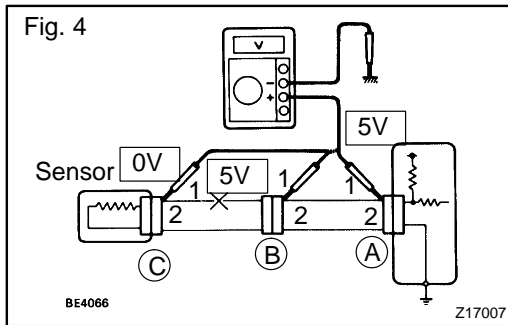
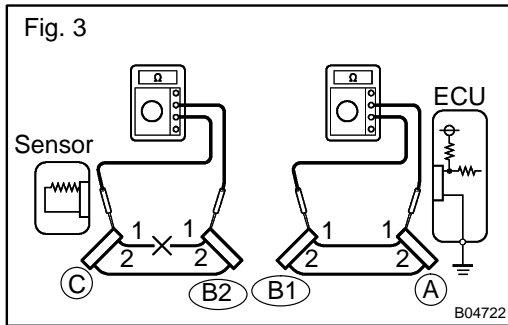

- (c) Check the voltage.

- (1) In a circuit in which voltage is applied (to the ECU connector terminal), an open circuit can be checked by conducting a voltage check.

As shown in Fig. 4, with each connector still connected, measure the voltage between the body ground and terminal 1 of connector A at the ECU 5 V output terminal, terminal 1 of connector B, and terminal 1 of connector C, in that order.

- (2) If the results are:
 5 V: Between terminal 1 of connector A and body ground
 5 V: Between terminal 1 of connector B and body ground
 0 V: Between terminal 1 of connector C and body ground
 Therefore, the cause is an open circuit in the wire harness between terminal 1 of connector B and terminal 1 of connector C.

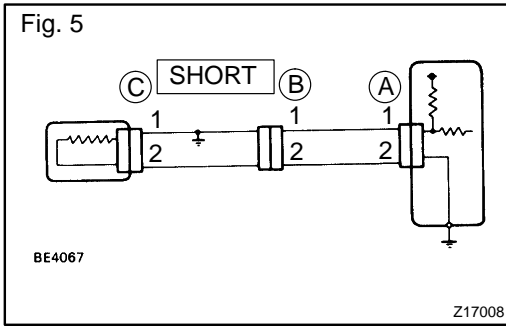

3. CHECK SHORT CIRCUIT

(a) If the wire harness is ground shorted as shown in Fig. 5, locate the section by conducting a resistance check with the body ground in step (b).

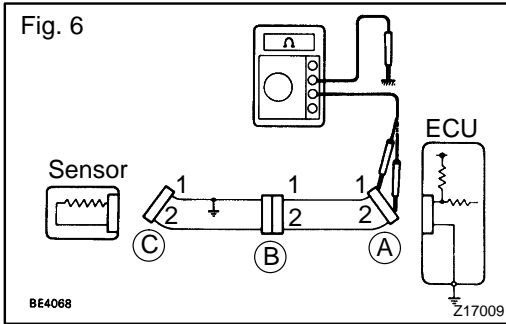

(b) Check the resistance with the body ground.
 (1) Disconnect connectors A and C and measure the resistance between terminals 1 and 2 of connector A and the body ground.

Resistance: 10 KΩ or higher

HINT:

Measure the resistance while lightly shaking the wire harness vertically and horizontally.

In the case of Fig. 6:

Between terminal 1 of connector A and body ground → Below 1 Ω

Between terminal 2 of connector A and body ground → 10 KΩ or higher

Therefore, the cause is a short circuit between terminal 1 of connector A and terminal 1 of connector C.

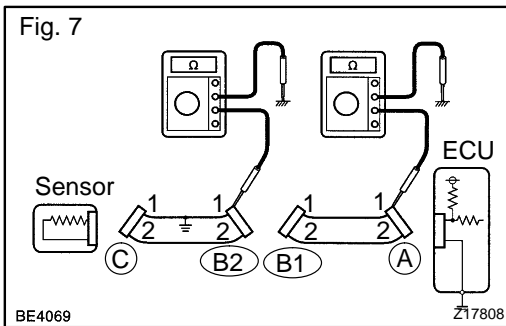

(2) Disconnect connector B and measure the resistance between terminal 1 of connector A and the body ground, and terminal 1 of connector B2 and the body ground.

In the case of Fig. 7:

Between terminal 1 of connector A and body ground → 10 KΩ or higher

Between terminal 1 of connector B2 and body ground → Below 1 Ω

Therefore, the cause is a short circuit between terminal 1 of connector B2 and terminal 1 of connector C.

4. CHECK AND REPLACE ECU

NOTICE:

- Start an inspection of the connector from the back-side of the connector on the wire harness side with the connector connected to the ECU.
 - When no measurement condition is specified, perform the inspection with the engine stopped and also the ignition switch ON.
- (a) First check the ECU ground circuit. If it is faulty, repair it. If it is normal, the ECU could be faulty. In this case, replace the ECU with one that functions normally and check if the symptoms appear.

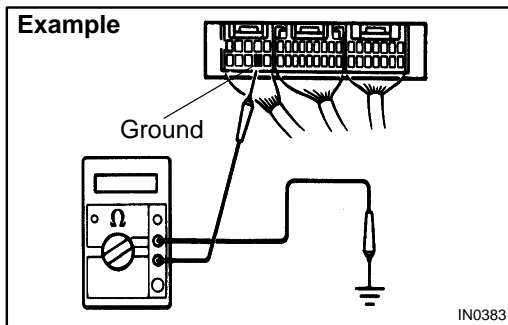

- (1) Measure the resistance between the ECU ground terminal and body ground.

Resistance: 1 Ω or less

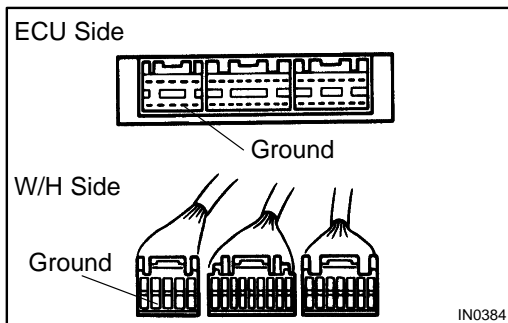

- (2) Disconnect the ECU connector, check the ground terminals on the ECU side and wire harness side for bends and check the contact pressure.

TERMS

ABBREVIATIONS USED IN THIS MANUAL

01037-07

Abbreviations	Meaning
ABS	Anti-Lock Brake System
AC	Alternating Current
ACC	Accessory
ACIS	Acoustic Control Induction System
ACSD	Automatic Cold Start Device
A.D.D.	Automatic Disconnecting Differential
A/F	Air-Fuel Ratio
AHC	Active Height Control Suspension
ALR	Automatic Locking Retractor
ALT	Alternator
AMP	Amplifier
ANT	Antenna
APPROX.	Approximately
ASSY	Assembly
A/T, ATM	Automatic Transmission (Transaxle)
ATF	Automatic Transmission Fluid
AUTO	Automatic
AUX	Auxiliary
AVG	Average
AVS	Adaptive Variable Suspension
B+	Battery Voltage
BA	Brake Assist
BACS	Boost Altitude Compensation System
BAT	Battery
BDC	Bottom Dead Center
B/L	Bi-Level
B/S	Bore-Stroke Ratio
BTDC	Before Top Dead Center
BVSV	Bimetallic Vacuum Switching Valve
Calif.	California
CB	Circuit Breaker
CCo	Catalytic Converter For Oxidation
CD	Compact Disc
CF	Cornering Force
CG	Center Of Gravity
CH	Channel
COMB.	Combination
CPE	Coupe
CPS	Combustion Pressure Sensor
CPU	Central Processing Unit
CRS	Child Restraint System
CTR	Center
C/V	Check Valve
CV	Control Valve
CW	Curb Weight
DC	Direct Current
DEF	Defogger
DFL	Deflector

Abbreviations	Meaning
DIFF.	Differential
DIFF. LOCK	Differential Lock
D/INJ	Direct Injection
DLC	Data Link Connector
DLI	Distributorless Ignition
DOHC	Double Overhead Camshaft
DP	Dash Pot
DS	Dead Soak
DSP	Digital Signal Processor
DTC	Diagnostic Trouble Code
DVD	Digital Versatile Disc
EBD	Electric Brake Force Distribution
ECAM	Engine Control And Measurement System
ECD	Electronic Controlled Diesel
ECDY	Eddy Current Dynamometer
ECU	Electronic Control Unit
ED	Electro-Deposited Coating
EDU	Electronic Driving Unit
EDIC	Electric Diesel Injection Control
EFI	Electronic Fuel Injection
E/G	Engine
EGR	Exhaust Gas Recirculation
EGR-VM	EGR-Vacuum Modulator
ELR	Emergency Locking Retractor
EMPS	Electric Motor Power Steering
ENG	Engine
ESA	Electronic Spark Advance
ETCS-i	Electronic Throttle Control System-intelligent
EVAP	Evaporative Emission Control
EVP	Evaporator
E-VRV	Electric Vacuum Regulating Valve
EX, EXH	Exhaust
FE	Fuel Economy
FF	Front-Engine Front-Wheel-Drive
F/G	Fuel Gauge
FIPG	Formed In Place Gasket
FL	Fusible Link
F/P	Fuel Pump
FPU	Fuel Pressure Up
Fr	Front
FR	Front-Engine Rear-Wheel-Drive
F/W	Flywheel
FW/D	Flywheel Damper
FWD	Front-Wheel-Drive
GAS	Gasoline
GND	Ground
GPS	Global Positioning System
HAC	High Altitude Compensator
H/B	Hatchback
H-FUSE	High Current Fuse
HI	High

INTRODUCTION – TERMS

Abbreviations	Meaning
HID	High Intensity Discharge (Head Lamp)
HPU	Hydraulic Power Unit
HSG	Housing
HT	Hard Top
HWS	Heated Windshield System
IAC	Idle Air Control
IC	Integrated Circuit
IDI	Indirect Diesel Injection
IFS	Independent Front Suspension
IG	Ignition
I/A	Integrated Ignition Assembly
IN	Intake (Manifold, Valve)
INT	Intermittent
I/P	Instrument Panel
IRS	Independent Rear Suspension
ISC	Idle Speed Control
J/B	Junction Block
J/C	Junction Connector
KD	Kick-Down
LAN	Local Area Network
LB	Liftback
LCD	Liquid Crystal Display
LED	Light Emitting Diode
LH	Left-Hand
LHD	Left-Hand Drive
L/H/W	Length, Height, Width
LLC	Long-Life Coolant
LNG	Liquified Natural Gas
LO	Low
LPG	Liquified Petroleum Gas
LSD	Limited Slip Differential
LSP & PV	Load Sensing Proportioning And Bypass Valve
LSPV	Load Sensing Proportioning Valve
MAP	Manifold Absolute Pressure
MAX.	Maximum
M-FUSE	Medium Current Fuse
MIC	Microphone
MIL	Malfunction Indicator Lamp
MIN.	Minimum
MG1	Motor Generator No.1
MG2	Motor Generator No.2
MP	Multipurpose
MPI	Multipoint Electronic Injection
MPX	Multiplex Communication System
M/T, MTM	Manual Transmission (Transaxle)
MT	Mount
MTG	Mounting
N	Neutral
NA	Natural Aspiration
No.	Number
O/D	Overdrive

Abbreviations	Meaning
OEM	Original Equipment Manufacturing
OHC	Overhead Camshaft
OHV	Overhead Valve
OPT	Option
ORVR	On-board Refilling Vapor Recovery
O/S	Oversize
P & BV	Proportioning And Bypass Valve
PCS	Power Control System
PCV	Positive Crankcase Ventilation
PKB	Parking Brake
PPS	Progressive Power Steering
PS	Power Steering
PTO	Power Take-Off
P/W	Power Window
R & P	Rack And Pinion
RAM	Random Access Memory
R/B	Relay Block
RBS	Recirculating Ball Type Steering
R/F	Reinforcement
RFS	Rigid Front Suspension
RH	Right-Hand
RHD	Right-Hand Drive
RLY	Relay
ROM	Read Only Memory
Rr	Rear
RR	Rear-Engine Rear-Wheel-Drive
RRS	Rigid Rear Suspension
RWD	Rear-Wheel-Drive
SDN	Sedan
SEN	Sensor
SICS	Starting Injection Control System
SMT	Sequential Manual Transmission
SOC	State Of Charge
SOHC	Single Overhead Camshaft
SPEC	Specification
SPI	Single Point Injection
SRS	Supplemental Restraint System
SSM	Special Service Materials
SST	Special Service Tools
STD	Standard
STJ	Cold-Start Fuel Injection
SW	Switch
SYS	System
T/A	Transaxle
TACH	Tachometer
TBI	Throttle Body Electronic Fuel Injection
TC	Turbocharger
TCCS	TOYOTA Computer-Controlled System
TCV	Timing Control Valve
TDC	Top Dead Center
TEMP.	Temperature

INTRODUCTION – TERMS

Abbreviations	Meaning
TEMS	TOYOTA Electronic Modulated Suspension
TFT	Toyota Free-Tronic
TIS	Total Information System For Vehicle Development
T/M	Transmission
TMC	TOYOTA Motor Corporation
TMMK	TOYOTA Motor Manufacturing Kentucky, Inc.
TRAC	Traction Control System
TURBO	Turbocharge
TWC	Three-Way Catalyst
TVIP	TOYOTA Vehicle Intrusion Protection
U/D	Underdrive
U/S	Undersize
VCV	Vacuum Control Valve
VENT	Ventilator
VIN	Vehicle Identification Number
VPS	Variable Power Steering
VSC	Vehicle Stability Control
VSV	Vacuum Switching Valve
VTV	Vacuum Transmitting Valve
VVT-i	Variable Valve Timing-intelligent
w/	With
WGN	Wagon
W/H	Wire Harness
w/o	Without
WU-TWC	Warm Up Three-way Catalytic Converter
WU-OC	Warm Up Oxidation Catalytic Converter
1st	First
2nd	Second
2WD	Two Wheel Drive Vehicle (4 x 2)
3rd	Third
4th	Fourth
4WD	Four Wheel Drive Vehicle (4 x 4)
4WS	Four Wheel Steering System
5th	Fifth

GLOSSARY OF SAE AND TOYOTA TERMS

This glossary lists all SAE-J1930 terms and abbreviations used in this manual in compliance with SAE recommendations, as well as their TOYOTA equivalents.

SAE ABBREVIATIONS	SAE TERMS	TOYOTA TERMS ()—ABBREVIATIONS
A/C	Air Conditioning	Air Conditioner
ACL	Air Cleaner	Air Cleaner, A/CL
AIR	Secondary Air Injection	Air Injection (AI)
AP	Accelerator Pedal	—
B+	Battery Positive Voltage	+B, Battery Voltage
BARO	Barometric Pressure	HAC
CAC	Charge Air Cooler	Intercooler
CARB	Carburetor	Carburetor
CFI	Continuous Fuel Injection	—
CKP	Crankshaft Position	Crank Angle
CL	Closed Loop	Closed Loop
CMP	Camshaft Position	Cam Angle
CPP	Clutch Pedal Position	—
CTOX	Continuous Trap Oxidizer	—
CTP	Closed Throttle Position	LL ON, Idle ON
DFI	Direct Fuel Injection (Diesel)	Direct Injection (DI)
DI	Distributor Ignition	—
DLC1 DLC2 DLC3	Data Link Connector 1 Data Link Connector 2 Data Link Connector 3	1. Check Connector 2. Total Diagnosis Communication Link (TDCL) 3. OBD II Diagnostic Connector
DTC	Diagnostic Trouble Code	Diagnostic Trouble Code
DTM	Diagnostic Test Mode	—
ECL	Engine Control Level	—
ECM	Engine Control Module	Engine ECU (Electronic Control Unit)
ECT	Engine Coolant Temperature	Coolant Temperature, Water Temperature (THW)
EEPROM	Electrically Erasable Programmable Read Only Memory	Electrically Erasable Programmable Read Only Memory (EEPROM), Erasable Programmable Read Only Memory (EPROM)
EFE	Early Fuel Evaporation	Cold Mixture Heater (CMH), Heat Control Valve (HCV)
EGR	Exhaust Gas Recirculation	Exhaust Gas Recirculation (EGR)
EI	Electronic Ignition	TOYOTA Distributorless Ignition (TDI)
EM	Engine Modification	Engine Modification (EM)
EPROM	Erasable Programmable Read Only Memory	Programmable Read Only Memory (PROM)
EVAP	Evaporative Emission	Evaporative Emission Control (EVAP)
FC	Fan Control	—
FEEPROM	Flash Electrically Erasable Programmable Read Only Memory	—
FEPROM	Flash Erasable Programmable Read Only Memory	—
FF	Flexible Fuel	—
FP	Fuel Pump	Fuel Pump
GEN	Generator	Alternator
GND	Ground	Ground (GND)

INTRODUCTION – TERMS

HO2S	Heated Oxygen Sensor	Heated Oxygen Sensor (HO ₂ S)
IAC	Idle Air Control	Idle Speed Control (ISC)
IAT	Intake Air Temperature	Intake or Inlet Air Temperature
ICM	Ignition Control Module	–
IFI	Indirect Fuel Injection	Indirect Injection (IDL)
IFS	Inertia Fuel–Shutoff	–
ISC	Idle Speed Control	–
KS	Knock Sensor	Knock Sensor
MAF	Mass Air Flow	Air Flow Meter
MAP	Manifold Absolute Pressure	Manifold Pressure Intake Vacuum
MC	Mixture Control	Electric Bleed Air Control Valve (EBCV) Mixture Control Valve (MCV) Electric Air Control Valve (EACV)
MDP	Manifold Differential Pressure	–
MFI	Multiport Fuel Injection	Electronic Fuel Injection (EFI)
MIL	Malfunction Indicator Lamp	Check Engine Lamp
MST	Manifold Surface Temperature	–
MVZ	Manifold Vacuum Zone	–
NVRAM	Non–Volatile Random Access Memory	–
O2S	Oxygen Sensor	Oxygen Sensor, O ₂ Sensor (O ₂ S)
OBD	On–Board Diagnostic	On–Board Diagnostic System (OBD)
OC	Oxidation Catalytic Converter	Oxidation Catalyst Convert (OC), CCo
OP	Open Loop	Open Loop
PAIR	Pulsed Secondary Air Injection	Air Suction (AS)
PCM	Powertrain Control Module	–
PNP	Park/Neutral Position	–
PROM	Programmable Read Only Memory	–
PSP	Power Steering Pressure	–
PTOX	Periodic Trap Oxidizer	Diesel Particulate Filter (DPF) Diesel Particulate Trap (DPT)
RAM	Random Access Memory	Random Access Memory (RAM)
RM	Relay Module	–
ROM	Read Only Memory	Read Only Memory (ROM)
RPM	Engine Speed	Engine Speed
SC	Supercharger	Supercharger
SCB	Supercharger Bypass	E–ABV
SFI	Sequential Multiport Fuel Injection	Electronic Fuel Injection (EFI), Sequential Injection
SPL	Smoke Puff Limiter	–
SRI	Service Reminder Indicator	–
SRT	System Readiness Test	–
ST	Scan Tool	–
TB	Throttle Body	Throttle Body
TBI	Throttle Body Fuel Injection	Single Point Injection Central Fuel Injection (Ci)
TC	Turbocharger	Turbocharger
TCC	Torque Converter Clutch	Torque Converter

TCM	Transmission Control Module	Transmission ECU, ECT ECU
TP	Throttle Position	Throttle Position
TR	Transmission Range	-
TVV	Thermal Vacuum Valve	Bimetallic Vacuum Switching Valve (BVSV) Thermostatic Vacuum Switching Valve (TVSV)
TWC	Three-Way Catalytic Converter	Three-Way Catalytic (TWC) Manifold Converter CC _{RO}
TWC+OC	Three-Way + Oxidation Catalytic Converter	CC _R + CCo
VAF	Volume Air Flow	Air Flow Meter
VR	Voltage Regulator	Voltage Regulator
VSS	Vehicle Speed Sensor	Vehicle Speed Sensor
WOT	Wide Open Throttle	Full Throttle
WU-OC	Warm Up Oxidation Catalytic Converter	-
WU-TWC	Warm Up Three-Way Catalytic Converter	-
3GR	Third Gear	-
4GR	Fourth Gear	-