

MANUAL TRANSAXLE SYSTEM

41075-01

PROBLEM SYMPTOMS TABLE

Use the table below to help you find the cause of the problem. The numbers indicate the priority of the likely cause of the problem. Check each part in order. If necessary, replace parts.

Symptom	Suspect Area	See page
Noise	6. Oil (Level low) 7. Oil (Wrong) 8. Gear (Worn or damaged) 9. Bearing (Worn or damaged)	41-2 41-2 41-63 41-74 41-63 41-74
Oil leakage	1. Oil (Level too high) 2. Gasket (Damaged) 3. Oil seal (Worn or damaged) 4. O-Ring (Worn or damaged)	41-2 41-28 41-3 41-28
Hard to shift or will not shift	1. Control cable (Faulty) 2. Synchronizer ring (Worn or damaged) 3. Shifting key spring (Damaged)	41-9 41-12 41-63 41-74 41-63 41-74
Jumps out of gear	1. Locking ball spring (Damaged) 2. Gear Shift fork (Worn) 3. Gear (Worn or damaged) 4. Bearing (Worn or damaged)	41-28 41-28 41-63 41-74 41-63 41-74

MANUAL TRANSAXLE OIL ON-VEHICLE INSPECTION

41076-01

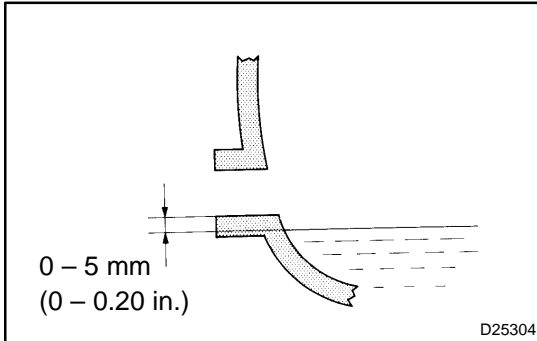

1. INSPECT TRANSAXLE OIL

- (a) Stop the vehicle on the level place.
- (b) Remove the transmission filler plug and gasket.
- (c) Check that the oil surface is within 5 mm (0.20 in.) from the lowest position of the inner surface of the transmission filler plug opening.

NOTICE:

- **Excessively large or small amount of oil may cause troubles.**
- **After replacing oil, drive the vehicle and check the oil level.**

- (d) Check for oil leakage when the oil level is low.
- (e) Install the transmission filler plug and new gasket.

Torque: 39.2 N·m (400 kgf·cm, 29 ft·lbf)

FRONT DIFFERENTIAL OIL SEAL REPLACEMENT

41077-02

1. DRAIN MANUAL TRANSAXLE OIL
Torque: 39.2 N·m (400 kgf·cm, 29 ft·lbf)
2. REMOVE FRONT WHEELS
3. REMOVE ENGINE UNDER COVER LH
4. REMOVE ENGINE UNDER COVER RH
5. DRAIN TRANSAXLE OIL
6. REMOVE FRONT DRIVE SHAFT ASSY LH (See page 30-6)
SST 09520-01010, 09520-24010 (09520-32040)
7. REMOVE FRONT DRIVE SHAFT ASSY RH (See page 30-6)
SST 09520-01010, 09520-24010 (09520-32040)

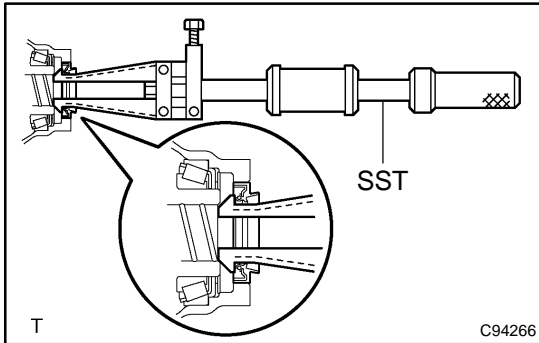

8. REMOVE TRANSAXLE CASE OIL SEAL

- (a) Using SST, remove the transaxle case oil seal.
SST 09308-00010

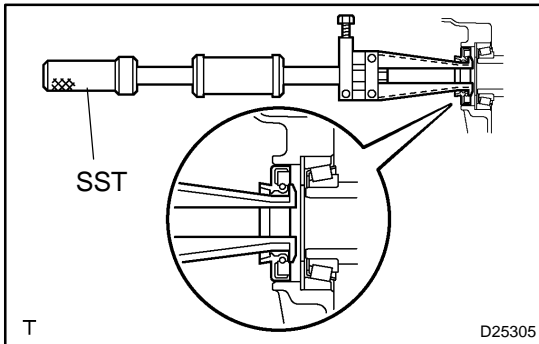

9. REMOVE TRANSMISSION CASE OIL SEAL

- (a) Using SST, remove the transmission case oil seal.
SST 09308-00010

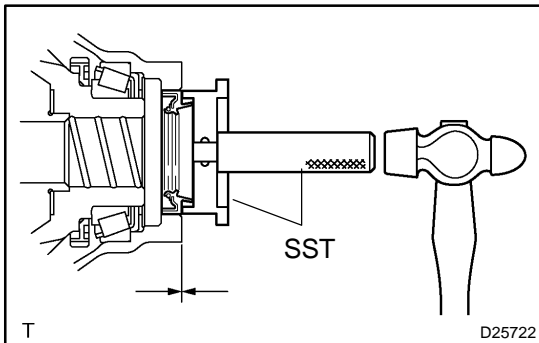

10. INSTALL TRANSAXLE CASE OIL SEAL

- (a) Coat a new oil seal lip with MP grease.
- (b) Using SST and a hammer, install the transaxle case oil seal.
SST 09554-14010, 09950-70010 (09951-07200)
Drive in depth: 1.9 ± 0.3 mm (0.075 ± 0.012 in.)

NOTICE:

Be careful not to damage the oil seal lip.

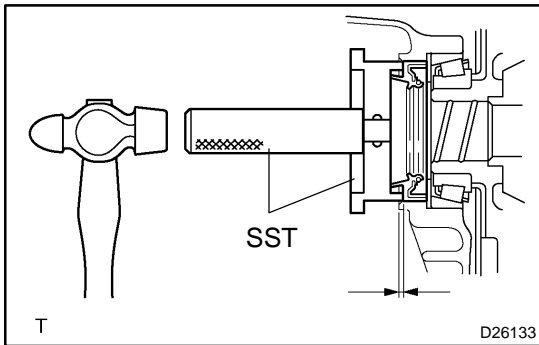
**11. INSTALL TRANSMISSION CASE OIL SEAL**

- (a) Coat a new oil seal lip with MP grease.
- (b) Using SST and a hammer, install the transmission case oil seal.

SST 09554-14010, 09950-70010 (09951-07200)

Drive in depth: 9.9 ± 0.3 mm (0.390 ± 0.012 in.)

NOTICE:

Be careful not to damage the oil seal lip.

12. INSTALL FRONT DRIVE SHAFT ASSY LH (See page 30-6)**13. INSTALL FRONT DRIVE SHAFT ASSY RH (See page 30-6)****14. INSTALL FRONT WHEELS**

Torque: 103 N·m (1,050 kgf·cm, 76 ft·lbf)

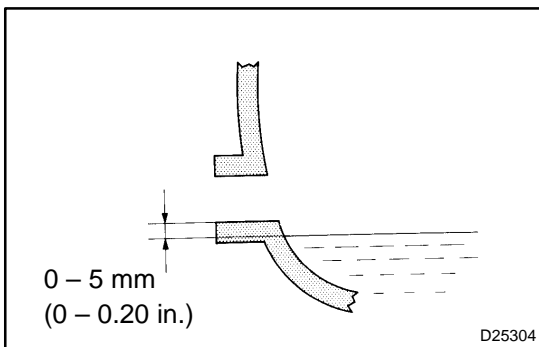
**15. ADD MANUAL TRANSAXLE OIL**

Oil grade: API GL-4 or GL-5

Viscosity: SAE 75 W-90

Capacity: 1.9 liters (2.0 US qts, 1.7 Imp. qts)

Torque: 39.2 N·m (400 kgf·cm, 29 ft·lbf)

16. INSPECT AND ADJUST MANUAL TRANSAXLE OIL (See page 41-2)**17. INSPECT AND ADJUST FRONT WHEEL ALIGNMENT (See page 26-5)****18. CHECK ABS SPEED SENSOR SIGNAL (See page 05-297)**

FLOOR SHIFT SHIFT LEVER ASSY COMPONENTS

4107A-01

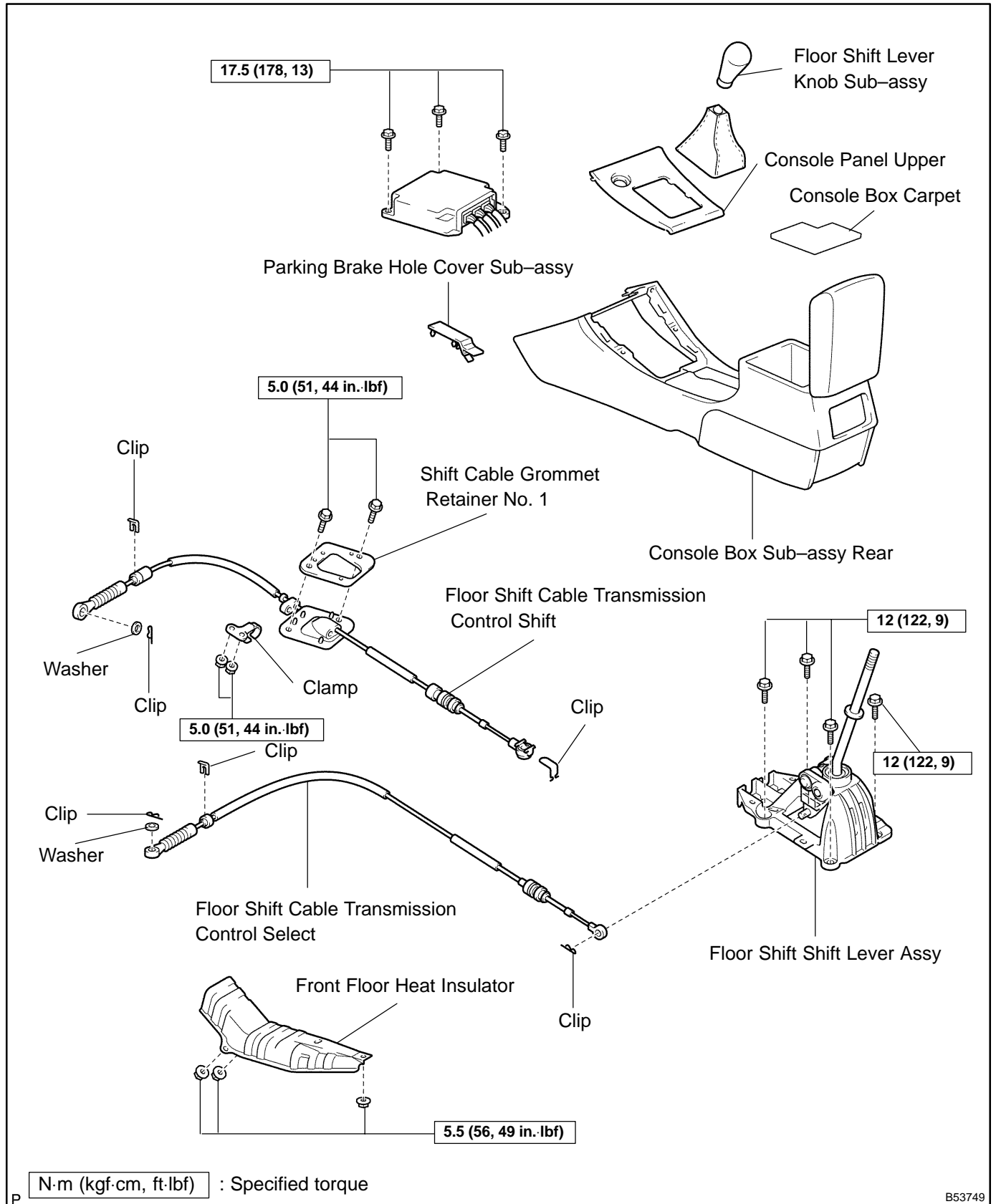

B53749

REPLACEMENT

HINT:

COMPONENTS: See page 41-5

1. REMOVE FLOOR SHIFT SHIFT LEVER KNOB SUB-ASSY
2. REMOVE CONSOLE PANEL UPPER (See page 71-10)
3. REMOVE PARKING BRAKE HOLE COVER SUB-ASSY (See page 71-10)
4. REMOVE CONSOLE BOX SUB-ASSY REAR (See page 71-10)

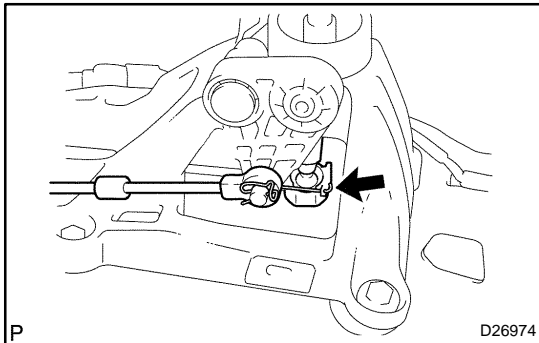

5. SEPARATE FLOOR SHIFT CABLE TRANSMISSION CONTROL SHIFT

- (a) Separate the end of the shift cable from the shift lever assy.

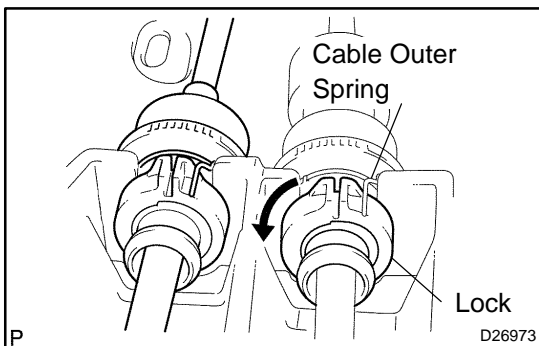

- (b) Using a screwdriver, release the cable outer spring.
- (c) Turn the lock, separate the shift cable from the shift lever retainer.

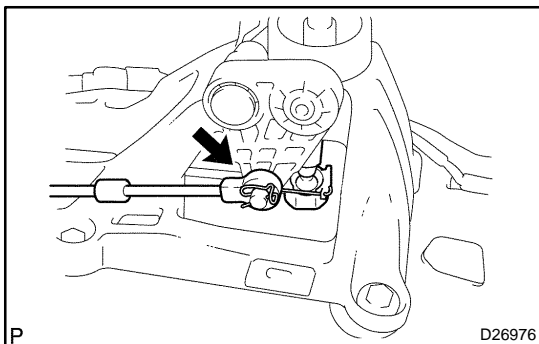

6. SEPARATE FLOOR SHIFT CABLE TRANSMISSION CONTROL SELECT

- (a) Separate the end of the select cable from the shift lever assy.

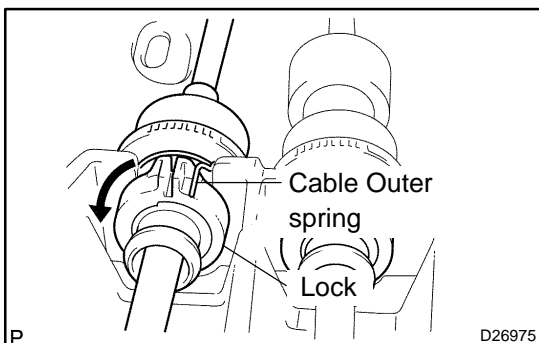

- (b) Using a screwdriver, release the cable outer spring.
- (c) Turn the lock, separate the select cable from the shift lever retainer.

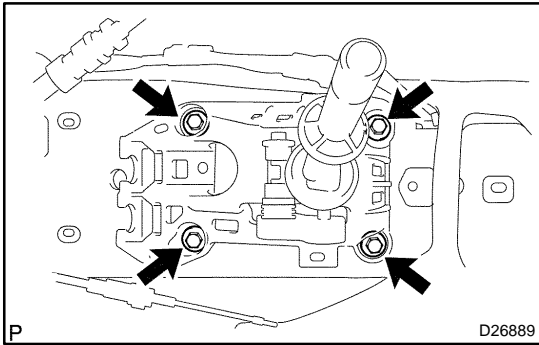

7. REMOVE FLOOR SHIFT SHIFT LEVER ASSY

- (a) Remove the 4 bolts and shift lever assy.

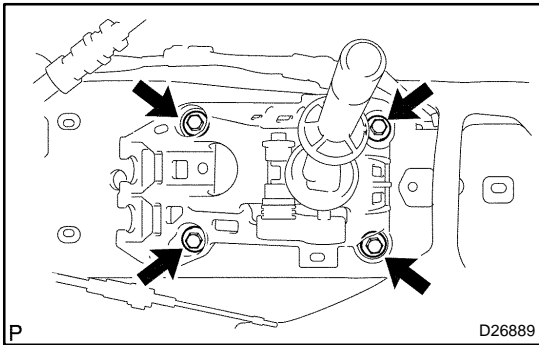

8. INSTALL FLOOR SHIFT SHIFT LEVER ASSY

- (a) Install the shift lever assy with the 4 bolts.
Torque: 12 N·m (120 kgf·cm, 9 ft·lbf)

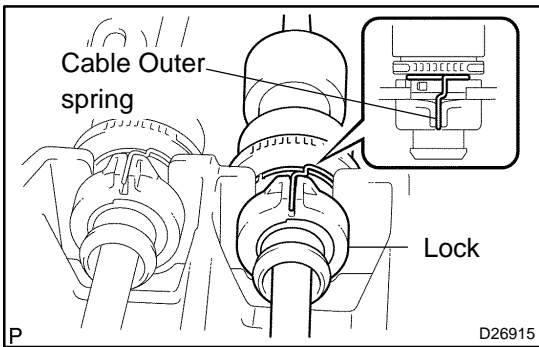

9. CONNECT FLOOR SHIFT CABLE TRANSMISSION CONTROL SHIFT

- (a) Connect the shift cable to the retainer of shift lever assy, turn the lock.

NOTICE:

The projecting part of the lock should face upward when the shift cable is installed.

- (b) Install the cable outer spring to the lock.

NOTICE:

Make sure that after installation the cable outer spring is moved to the place shown in the illustration.

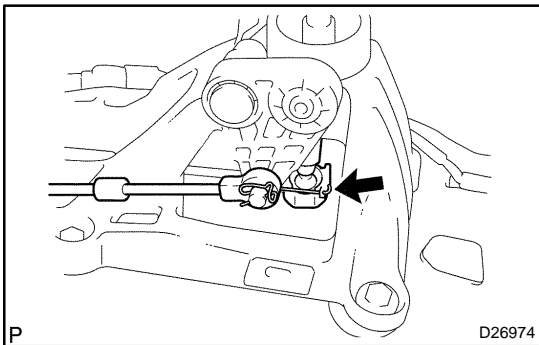

- (c) Connect the end of the shift cable to the shift lever assy.

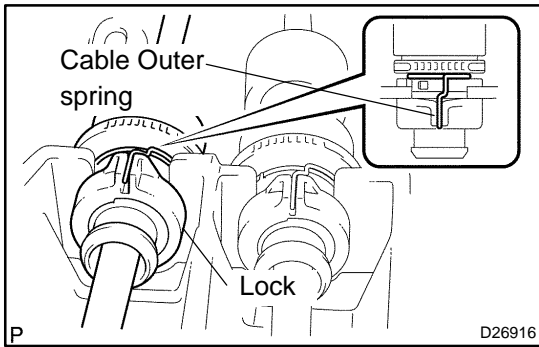

10. CONNECT FLOOR SHIFT CABLE TRANSMISSION CONTROL SELECT

- (a) Connect the select cable to the retainer of shift lever assy, turn the lock.

NOTICE:

The projecting part of the lock should face upward when the select cable is installed.

- (b) Install the cable outer spring to the lock.

NOTICE:

Make sure that after installation the cable outer spring is moved to the place shown in the illustration.

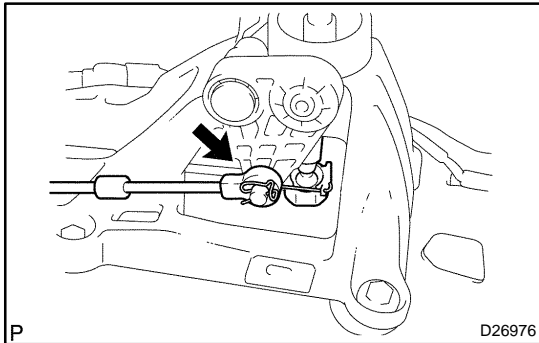

- (c) Connect the end of the select cable to the shift lever assy.

FLOOR SHIFT CABLE TRANSMISSION CONTROL SHIFT REPLACEMENT

41078-02

HINT:

COMPONENTS: See page 41-5

1. REMOVE AIR CONDITIONER UNIT ASSY (See page 55-17)

HINT:

Refer to the instructions for removal of the air conditioner unit assy.

2. SEPARATE AIR BAG SENSOR ASSY CENTER

(a) Remove the 3 bolts, separate the airbag sensor assy center.

3. REMOVE EXHAUST PIPE ASSY (See page 15-2)

4. REMOVE FRONT FLOOR HEAT INSULATOR NO.1

(a) Remove the 3 nuts and heat insulator No.1.

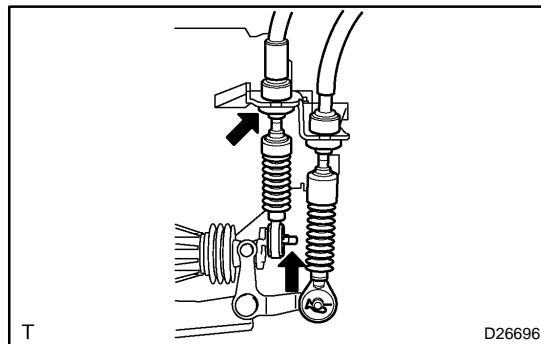

5. REMOVE FLOOR SHIFT CABLE TRANSMISSION CONTROL SHIFT

(a) Remove the clip and washer, separate the top of the shift cable from the transaxle.

(b) Remove the clip, separate the shift cable from the control cable bracket.

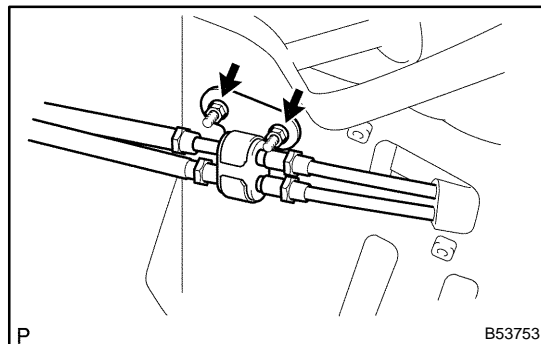

(c) Remove the 2 nuts and clamp.

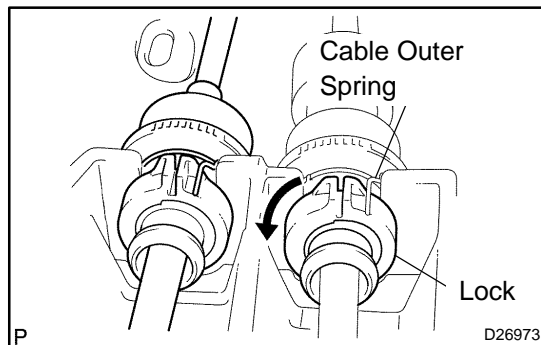

(d) Using a screwdriver, release the cable outer spring.

(e) Turn the lock, separate the shift cable from the shift lever retainer.

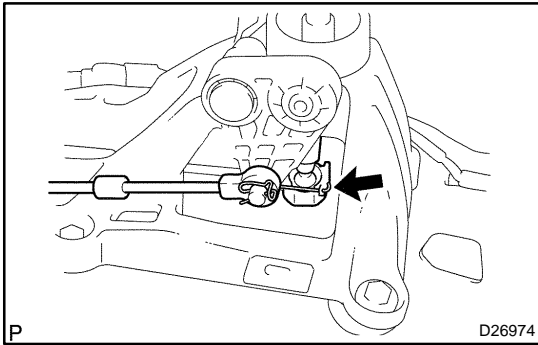

- (f) Separate the end of the shift cable from the shift lever assy.

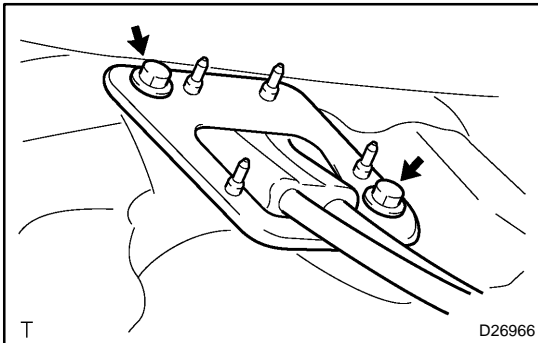

- (g) Remove the 2 bolts and retainer from the floor.
(h) Pull out the control cable assy from the floor.

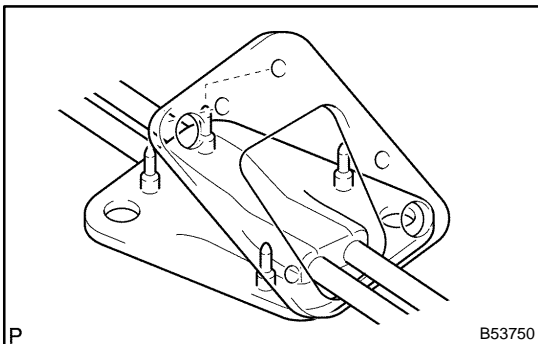

- (i) Remove the retainer from the grommet.

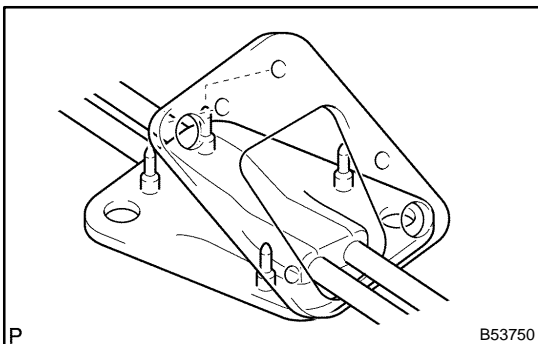

6. INSTALL FLOOR SHIFT CABLE TRANSMISSION CONTROL SHIFT

- (a) Put the control cable assy through the floor hole and retainer.
(b) Install the retainer to the grommet.

NOTICE:

Fit 4 projections of the grommet into 4 holes of the retainer.

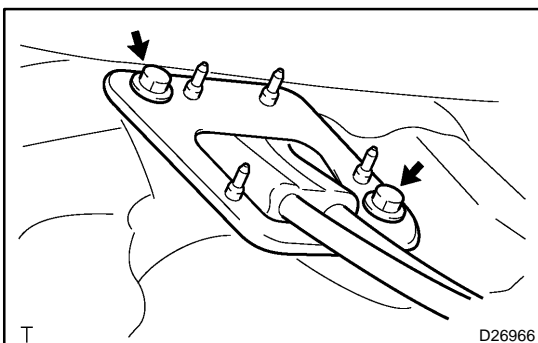

- (c) Install the control cable assy with the 2 bolts.
Torque: 5.0 N·m (51 kgf·cm, 44 in·lbf)

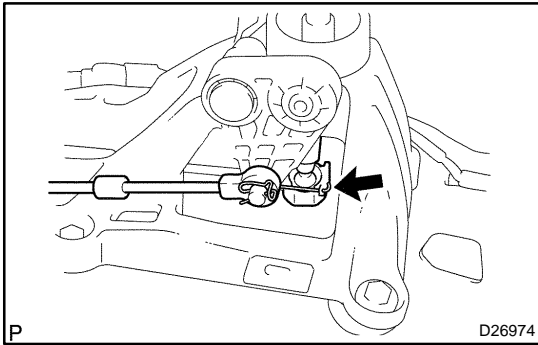

- (d) Connect the end of the shift cable to the shift lever assy.

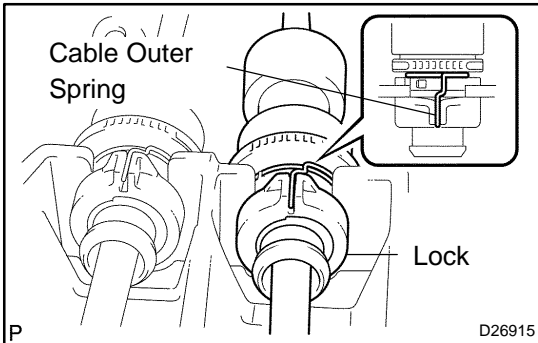

- (e) Connect the shift cable to the retainer of shift lever assy, turn the lock.

NOTICE:

The projecting part of the lock should face upward when the shift cable is installed.

- (f) Install the cable outer spring to the lock.

NOTICE:

Make sure that after installation the cable outer spring is moved to the place shown in the illustration.

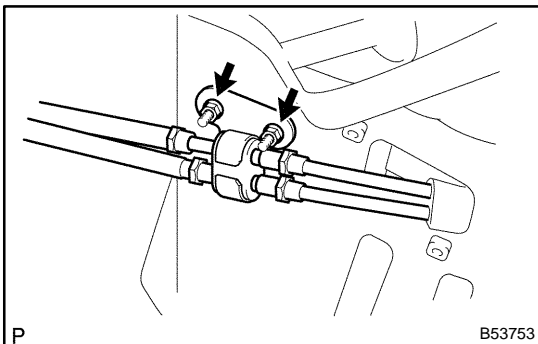

- (g) Install the clamp with the 2 nuts.

Torque: 5.0 N·m (51 kgf·cm, 44 in·lbf)

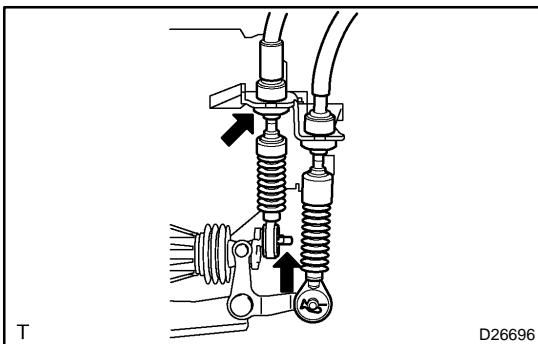

- (h) Connect the shift cable to the control cable bracket, install a new clip.

- (i) Connect the shift cable to the transaxle, install the washer and clip.

7. INSTALL FRONT FLOOR HEAT INSULATOR NO.1

- (a) Install the heat insulator No.1 with the 3 nuts.

Torque: 5.5 N·m (56 kgf·cm, 49 in·lbf)

8. INSTALL EXHAUST PIPE ASSY (See page 15-2)

9. CONNECT AIR BAG SENSOR ASSY CENTER

- (a) Install the airbag sensor assy center with the 3 bolts.

Torque: 17.5 N·m (178 kgf·cm, 13 ft·lbf)

10. INSPECT SRS WARNING LIGHT (See page 05-424)

FLOOR SHIFT CABLE TRANSMISSION CONTROL SELECT REPLACEMENT

41079-02

HINT:

COMPONENTS: See page 41-5

1. REMOVE AIR CONDITIONER UNIT ASSY (See page 55-17)

HINT:

Refer to the instructions for removal of the air conditioner unit assy.

2. SEPARATE AIR BAG SENSOR ASSY CENTER

(a) Remove the 3 bolts, separate the airbag sensor assy center.

3. REMOVE EXHAUST PIPE ASSY (See page 15-2)

4. REMOVE FRONT FLOOR HEAT INSULATOR NO.1

(a) Remove the 3 nuts and heat insulator No.1.

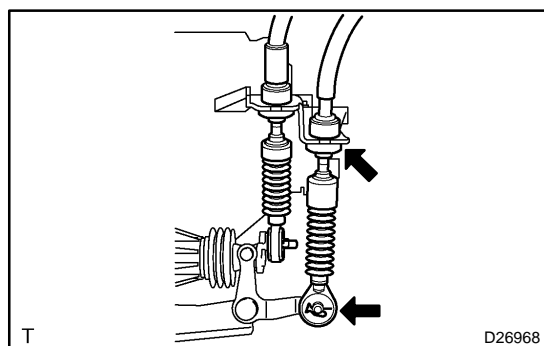

5. REMOVE FLOOR SHIFT CABLE TRANSMISSION CONTROL SELECT

(a) Remove the clip and washer, separate the top of the select cable from the transaxle.

(b) Remove the clip, separate the select cable from the control cable bracket.

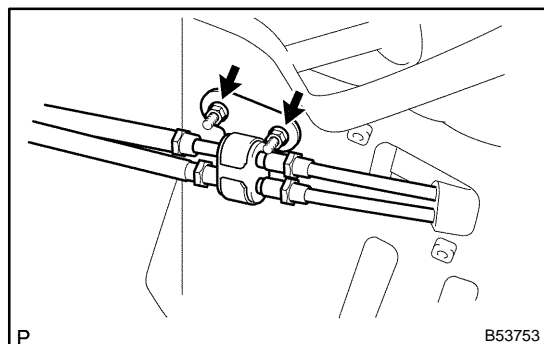

(c) Remove the 2 nuts and clamp.

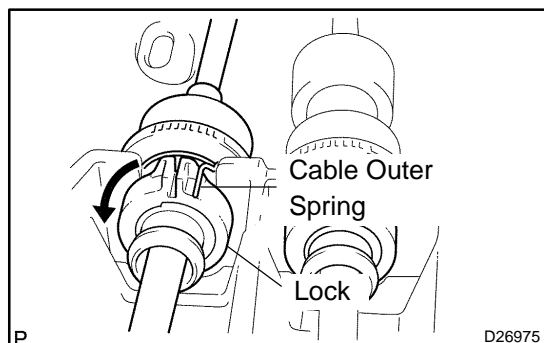

(d) Using a screwdriver, release the cable outer spring.

(e) Turn the lock, separate the select cable from the shift lever retainer.

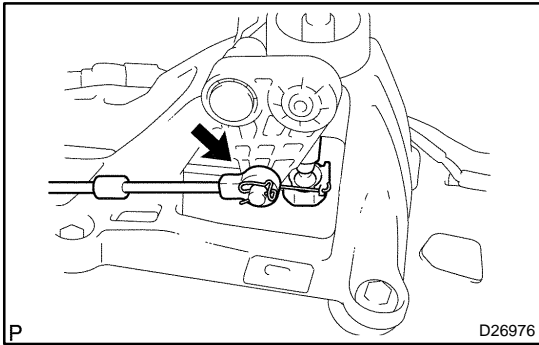

- (f) Separate the end of the select cable from the shift lever assy.

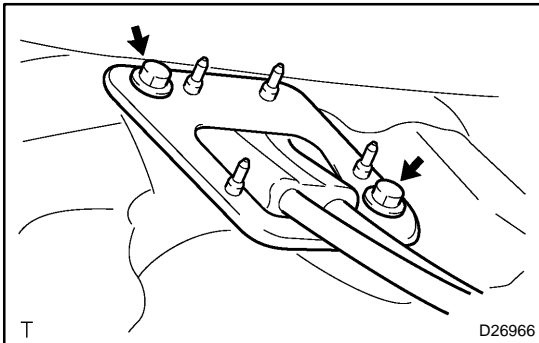

- (g) Remove the 2 bolts and retainer from the floor.
(h) Pull out the control cable assy from the floor.

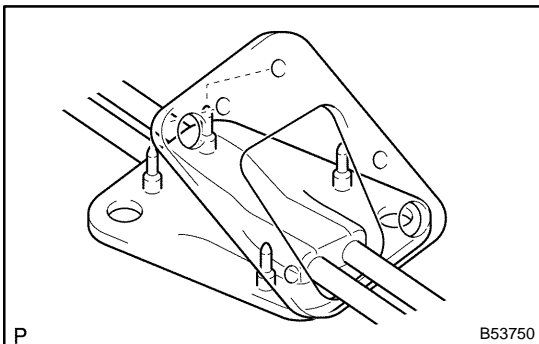

- (i) Remove the retainer from the grommet.
(j) Remove the select cable from the grommet.

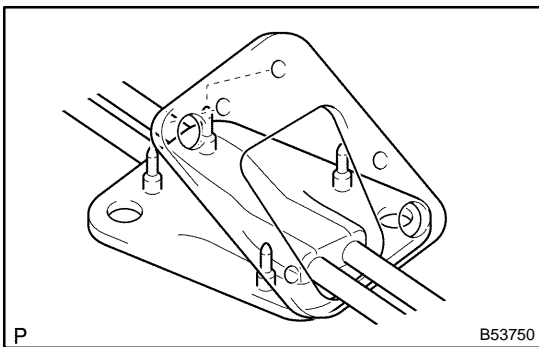

6. INSTALL FLOOR SHIFT CABLE TRANSMISSION CONTROL SELECT

- (a) Install the select cable to the grommet.
(b) Install the retainer to the grommet.

NOTICE:

Fit 4 projections of the grommet into 4 holes of the retainer.

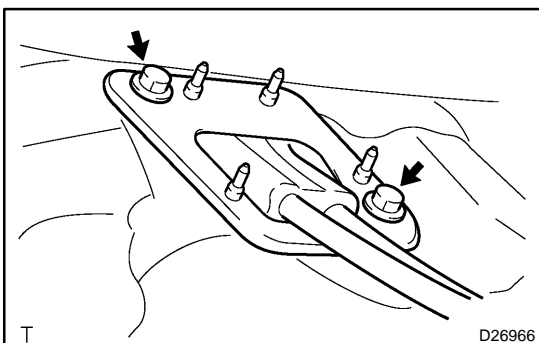

- (c) Install the control cable assy with the 2 bolts.
Torque: 5.0 N·m (51 kgf·cm, 44 in·lbf)

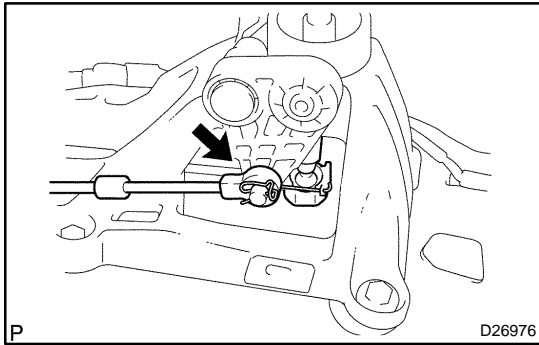

- (d) Connect the end of the select cable to the shift lever assy.

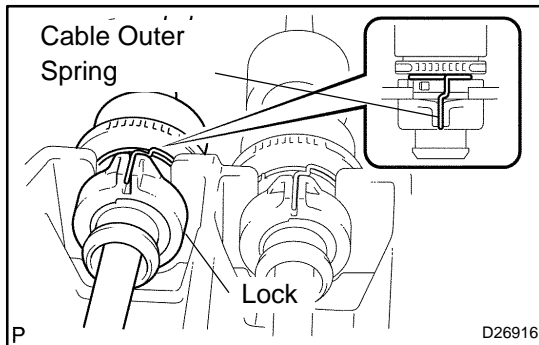

- (e) Connect the select cable to the retainer of shift lever assy, turn the lock.

NOTICE:

The projecting part of the lock should face upward when the select cable is installed.

- (f) Install the cable outer spring to the lock.

NOTICE:

Make sure that after installation the cable outer spring is moved to the place shown in the illustration.

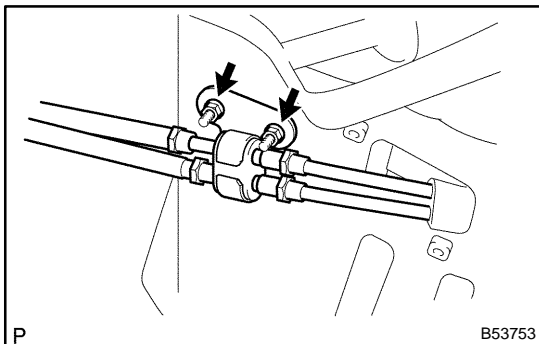

- (g) Install the clamp with the 2 nuts.

Torque: 5.0 N·m (51 kgf·cm, 44 in·lbf)

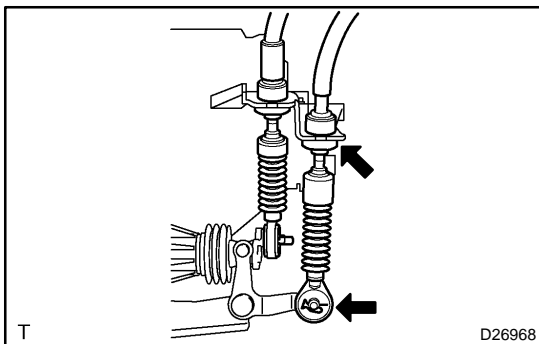

- (h) Connect the select cable to the control cable bracket, install a new clip.

- (i) Connect the select cable to the transaxle, install the washer and clip.

7. INSTALL FRONT FLOOR HEAT INSULATOR NO.1

- (a) Install the heat insulator No.1 with the 3 nuts.

8. INSTALL EXHAUST PIPE ASSY (See page 15-2)

9. CONNECT AIR BAG SENSOR ASSY CENTER

- (a) Install the airbag sensor assy center with the 3 bolts.

Torque: 17.5 N·m (178 kgf·cm, 13 ft·lbf)

10. INSPECT SRS WARNING LIGHT (See page 05-424)

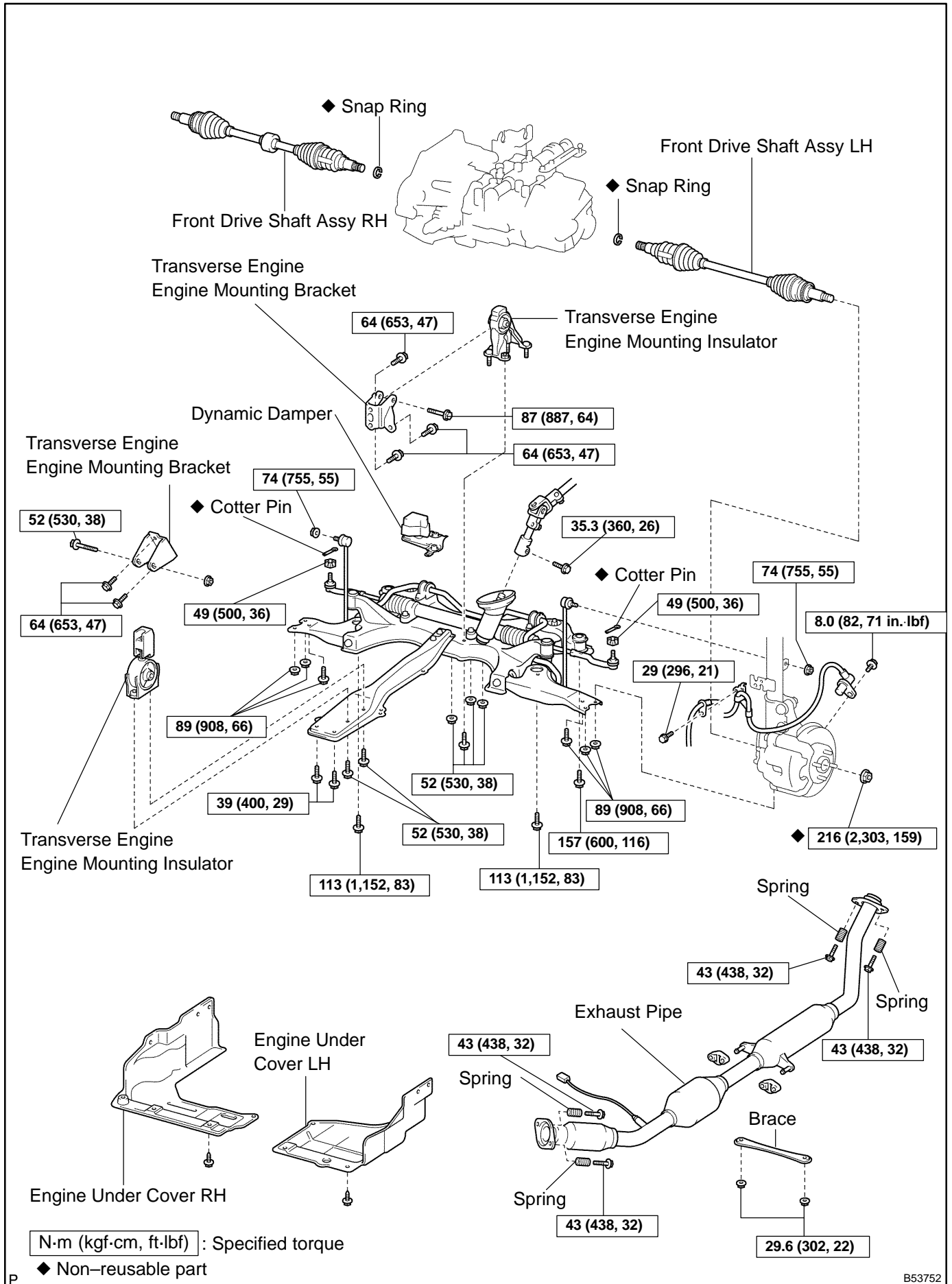

B53752

REPLACEMENT

HINT:

COMPONENTS: See page 41-15

1. PLACE FRONT WHEELS FACING STRAIGHT AHEAD
2. REMOVE FRONT WHEELS
3. REMOVE ENGINE UNDER COVER LH
4. REMOVE ENGINE UNDER COVER RH
5. REMOVE EXHAUST PIPE (See page 15-2)
6. DRAIN TRANSAXLE OIL
7. REMOVE HOOD SUB-ASSY
8. REMOVE CYLINDER HEAD COVER NO.2
9. REMOVE AIR CLEANER ASSY
10. REMOVE BATTERY CLAMP SUB-ASSY
11. REMOVE BATTERY
12. REMOVE BATTERY TRAY

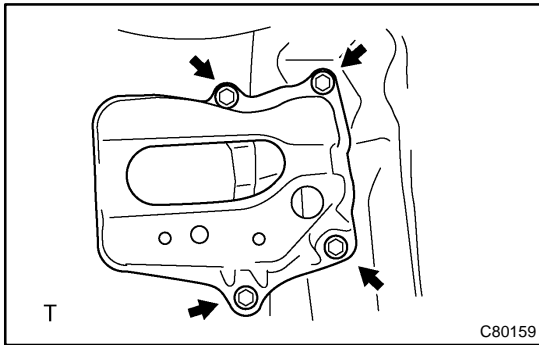

13. REMOVE BATTERY CARRIER

- (a) Remove the 4 bolts and battery carrier.

14. REMOVE CRUISE CONTROL ACTUATOR ASSY (W/ CRUISE CONTROL) (See page 82-4)

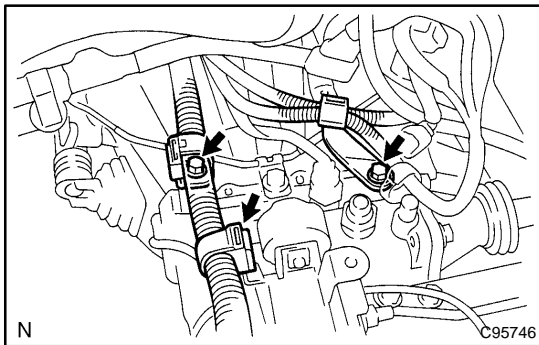

15. DISCONNECT WIRE HARNESS

- (a) Disconnect the wire harness clamp.
- (b) Remove the 2 bolts and disconnect the 2 wire harness brackets.

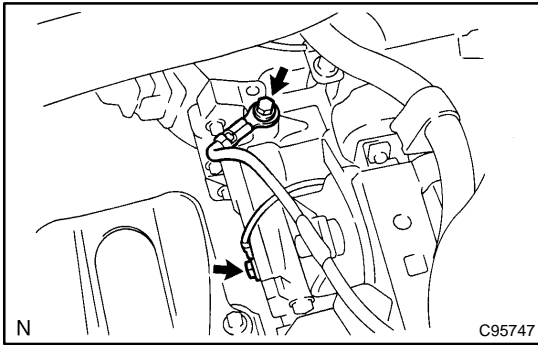

- (c) Remove the 2 bolts and 2 ground cables.

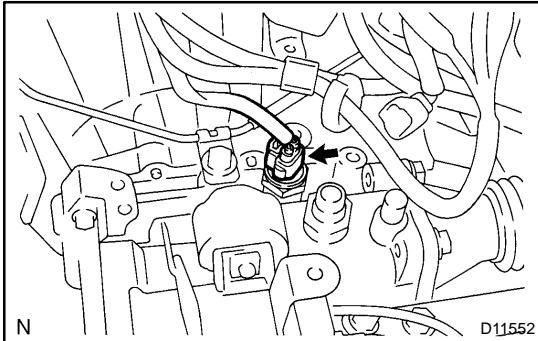

16. DISCONNECT CONNECTOR

- (a) Disconnect the back-up lamp switch connector.

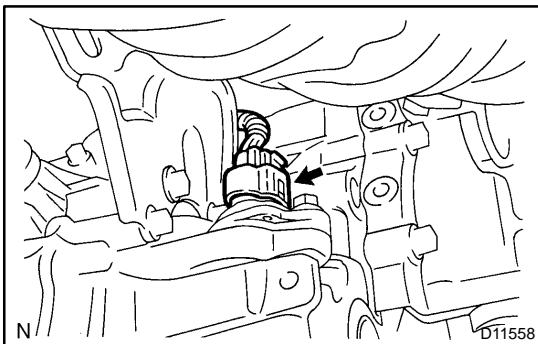

- (b) w/o ABS:
Disconnect the speed sensor connector.

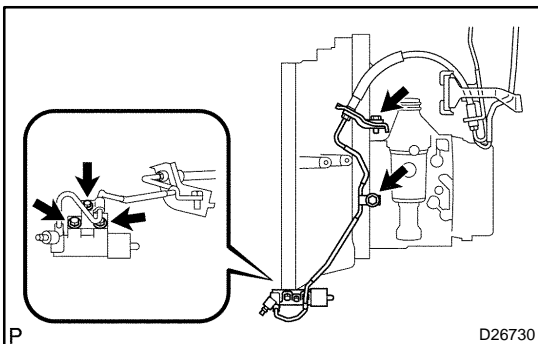

17. SEPARATE CLUTCH RELEASE CYLINDER ASSY

- (a) Remove the 5 bolts, separate the release cylinder assy with clutch piping from the transaxle.

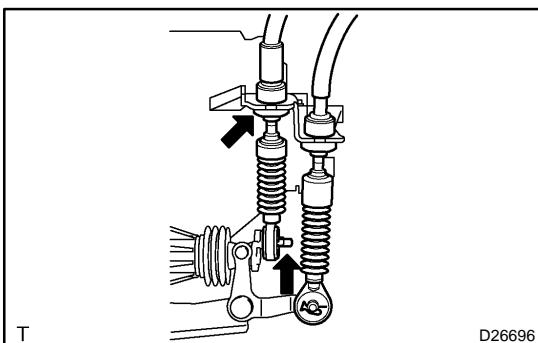

18. SEPARATE FLOOR SHIFT CABLE TRANSMISSION CONTROL SHIFT

- (a) Remove the clip, washer and disconnect the shift cable from the transaxle.
(b) Remove the clip and disconnect the shift cable from the bracket.

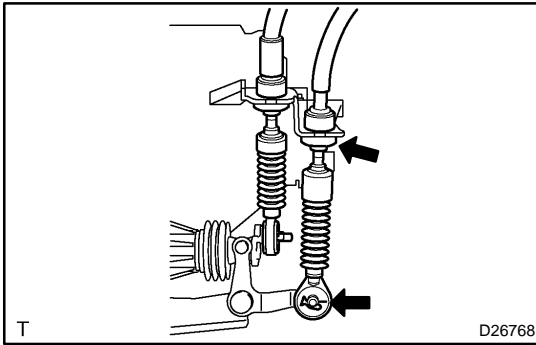

19. SEPARATE FLOOR SHIFT CABLE TRANSMISSION CONTROL SELECT

- (a) Remove the clip, washer and disconnect the select cable from the transaxle.
- (b) Remove the clip and disconnect the select cable from the bracket.

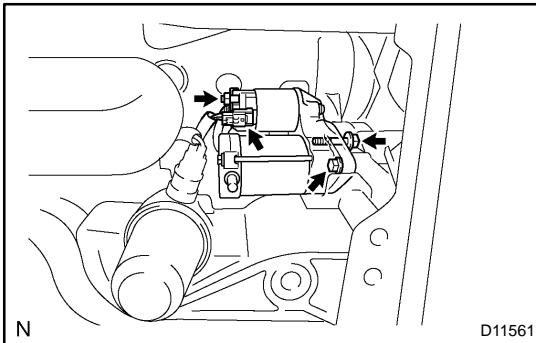

20. REMOVE STARTER ASSY

- (a) Remove the nut and disconnect the starter wire.
- (b) Disconnect the connector.
- (c) Remove the 2 bolts and starter assy.

21. SEPARATE STEERING INTERMEDIATE SHAFT (See page 51-18)

22. REMOVE FRONT DRIVE SHAFT ASSY LH (See page 30-6)

SST 09520-01010, 09520-24010 (09520-32040)

23. REMOVE FRONT DRIVE SHAFT ASSY RH

HINT:

Remove the RH side by the same procedures as LH side.

SST 09520-01010, 09520-24010 (09520-32040)

24. SEPARATE RETURN TUBE SUB-ASSY (See page 51-18)

SST 09023-12700

25. SEPARATE PRESSURE FEED TUBE ASSY (See page 51-18)

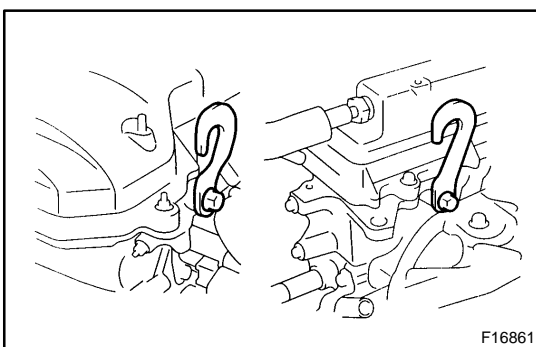

26. SUSPEND ENGINE ASSY

- (a) Remove the 2 PCV hoses.
- (b) Install the 2 hangers in the correct direction.

Parts No.:

Engine hanger: 12281-22021

No.1 engine hanger: 12281-15040

Bolt: 91512-B1016

Torque: 38 N·m (387 kgf·cm, 28 ft·lbf)

- (c) Attach the engine chain hoist to the hangers.

CAUTION:

Do not attempt to hang the engine by hooking the chain to any other part.

27. REMOVE FRONT SUSPENSION CROSSMEMBER SUB-ASSY (See page 26-13)

28. SUPPORT MANUAL TRANSAXLE ASSY

- (a) Support the transaxle with a transmission jack.

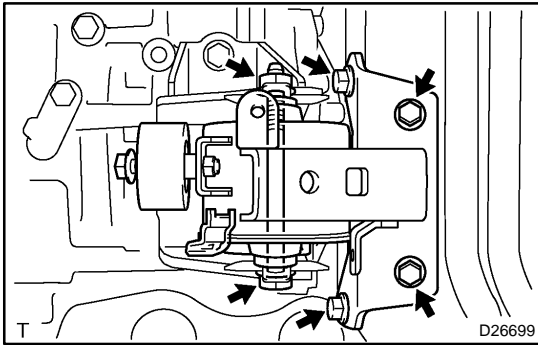

29. REMOVE TRANSVERSE ENGINE ENGINE MOUNTING INSULATOR

- (a) Remove the 5 bolts, nut and engine mounting insulator LH from the body.

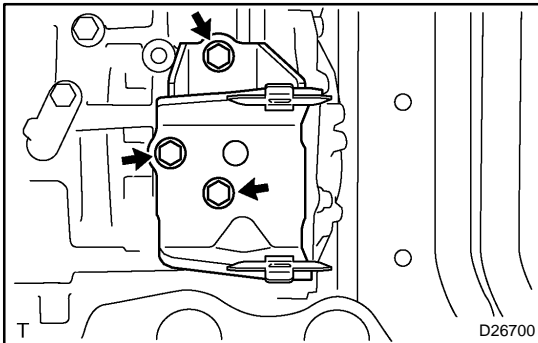

30. REMOVE TRANSVERSE ENGINE ENGINE MOUNTING BRACKET

- (a) Remove the 3 bolts and engine mounting bracket LH from the transaxle.

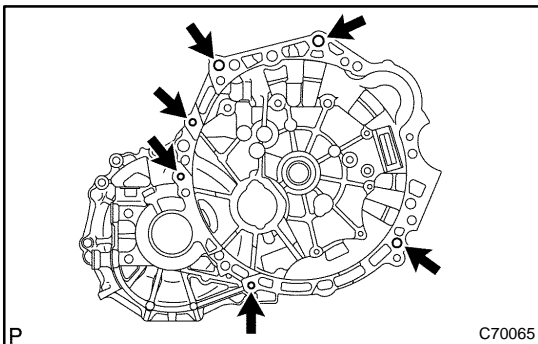

31. REMOVE MANUAL TRANSAXLE ASSY

- (a) Remove the 6 bolts and transaxle from the engine.

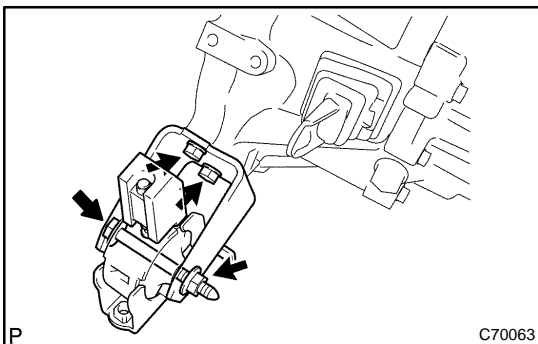

32. REMOVE TRANSVERSE ENGINE ENGINE MOUNTING BRACKET

- (a) Remove the bolt, nut and engine mounting insulator FR from the engine mounting bracket FR.
 (b) Remove the 2 bolts and engine mounting bracket FR from the transaxle.

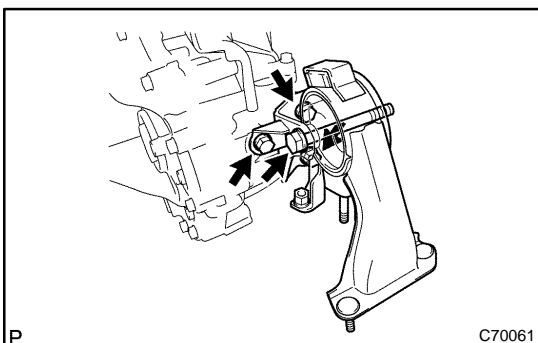

33. REMOVE TRANSVERSE ENGINE ENGINE MOUNTING BRACKET

- (a) Remove the bolt and engine mounting insulator RR from the engine mounting bracket RR.
 (b) Remove the 3 bolts and engine mounting bracket RR from the transaxle.

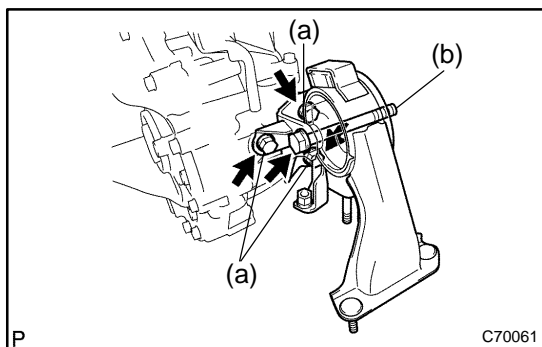

34. INSTALL TRANSVERSE ENGINE ENGINE MOUNTING BRACKET

- (a) Install the engine mounting bracket RR and 3 bolts to the transaxle.

Torque: 64 N·m (653 kgf·cm, 47 ft·lbf)

- (b) Install the engine mounting insulator RR and bolt to the engine mounting bracket RR.

Torque: 87 N·m (888 kgf·cm, 64 ft·lbf)

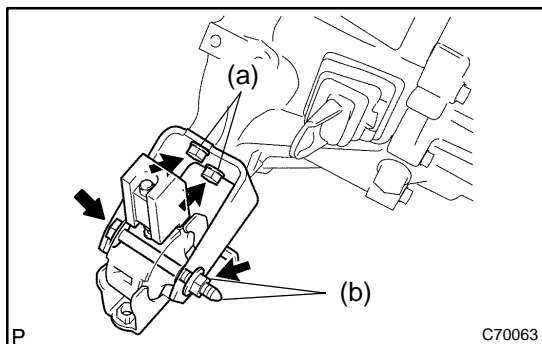

35. INSTALL TRANSVERSE ENGINE ENGINE MOUNTING BRACKET

- (a) Install the engine mounting bracket FR and 2 bolts to the transaxle.

Torque: 64 N·m (653 kgf·cm, 47 ft·lbf)

- (b) Install the engine mounting insulator FR, bolt and nut to the engine mounting bracket FR.

Torque: 52 N·m (530 kgf·cm, 38 ft·lbf)

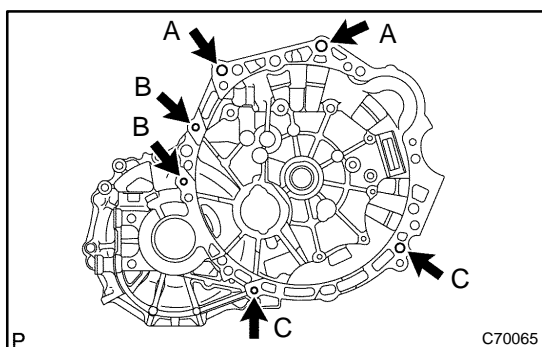

36. INSTALL MANUAL TRANSAXLE ASSY

- (a) Align the input shaft with the clutch disc and install the transaxle to the engine.

- (b) Install the 6 bolts.

Torque:

Bolt A: 64 N·m (650 kgf·cm, 47 ft·lbf)

Bolt B: 47 N·m (480 kgf·cm, 35 ft·lbf)

Bolt C: 23 N·m (230 kgf·cm, 17 ft·lbf)

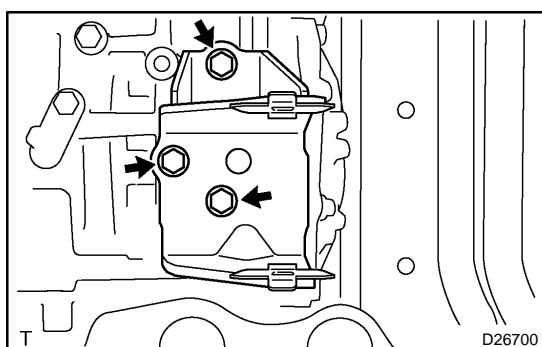

37. INSTALL TRANSVERSE ENGINE ENGINE MOUNTING BRACKET

- (a) Install the engine mounting bracket LH to the transaxle with the 3 bolts.

Torque: 52 N·m (530 kgf·cm, 38 ft·lbf)

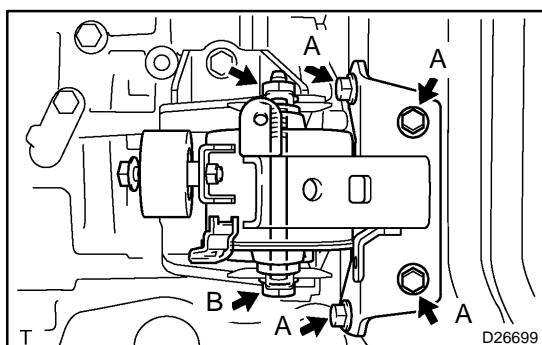

38. INSTALL TRANSVERSE ENGINE ENGINE MOUNTING INSULATOR

- (a) Install the engine mounting insulator LH with the 5 bolts and nut.

Torque:

Bolt A: 52 N·m (530 kgf·cm, 38 ft·lbf)

Bolt B: 80 N·m (816 kgf·cm, 59 ft·lbf)

39. **INSTALL FRONT SUSPENSION CROSSMEMBER SUB-ASSY (See page 26-13)**
SST 09670-00010
40. **CONNECT STEERING INTERMEDIATE SHAFT (See page 51-18)**
41. **INSTALL COLUMN HOLE COVER SILENCER SHEET (See page 51-18)**
42. **CONNECT RETURN TUBE SUB-ASSY (See page 51-18)**
SST 09023-12700
43. **CONNECT PRESSURE FEED TUBE ASSY (See page 51-18)**
SST 09023-12700
44. **INSTALL FRONT DRIVE SHAFT ASSY LH (See page 30-6)**
45. **INSTALL FRONT DRIVE SHAFT ASSY RH**

HINT:

Install the RH side by the same procedures as LH side.

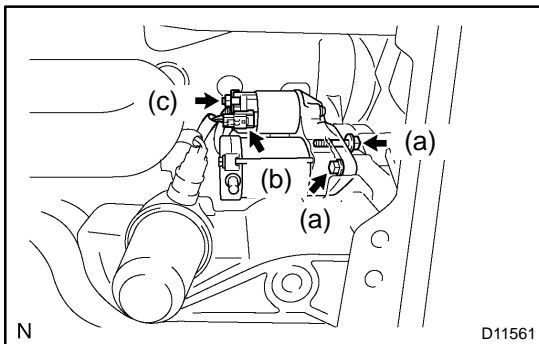
**46. INSTALL STARTER ASSY**

- (a) Install the starter assy and 2 bolts to the transaxle.
Torque: 37 N·m (378 kgf·cm, 27 ft·lbf)
- (b) Connect the starter connector.
- (c) Install the wire and nut to starter assy.
Torque: 9.8 N·m (100 kgf·cm, 87 in·lbf)

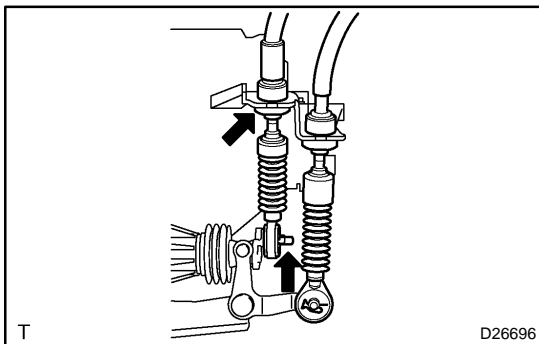
**47. CONNECT FLOOR SHIFT CABLE TRANSMISSION CONTROL SHIFT**

- (a) Connect the shift cable end, and install the washer and clip.

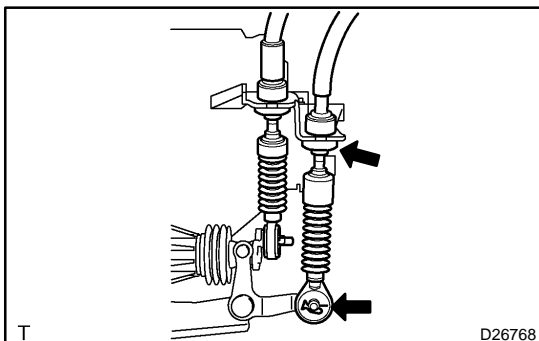
**48. CONNECT FLOOR SHIFT CABLE TRANSMISSION CONTROL SELECT**

- (a) Connect the select cable end, and install the washer and clip.

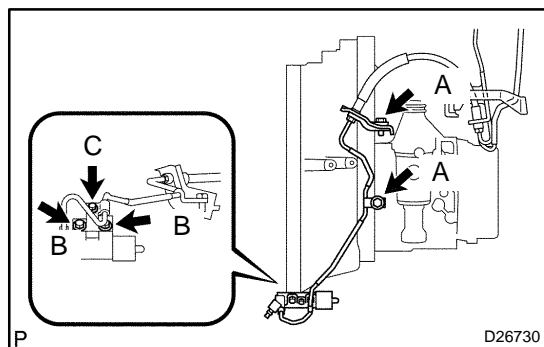
**49. CONNECT CLUTCH RELEASE CYLINDER ASSY**

- (a) Install the release cylinder with the 5 bolts.

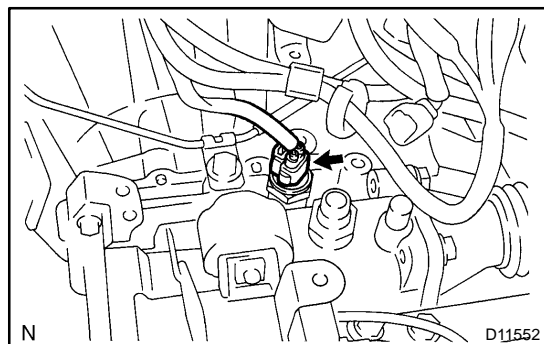
Torque:**Bolt A: 25 N·m (250 kgf·cm, 19 ft·lbf)****Bolt B: 12 N·m (120 kgf·cm, 9 ft·lbf)****Bolt C: 5.0 N·m (51 kgf·cm, 44 in·lbf)****50. CONNECT CONNECTOR**

- (a) Connect the back-up lamp switch connector.

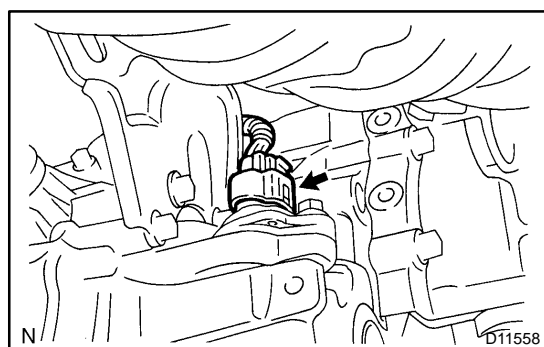

- (b) w/o ABS:

Connect the speed sensor connector.

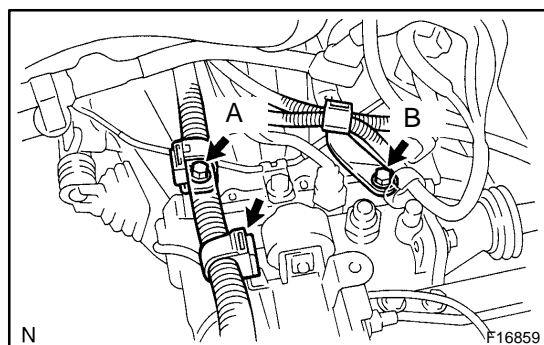
**51. CONNECT WIRE HARNESS**

- (a) Install the 2 wire harness clamps to the transaxle with the 2 bolts.

Torque:**Bolt A: 25.5 N·m (260 kgf·cm, 19 ft·lbf)****Bolt B: 12.8 N·m (131 kgf·cm, 9 ft·lbf)**

- (1) Connect the wire harness clamp.

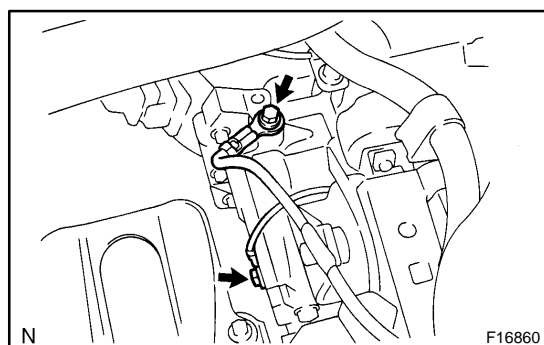

- (b) Install the 2 bolts and 2 ground cables.

Torque: 13 N·m (133 kgf·cm, 10 ft·lbf)

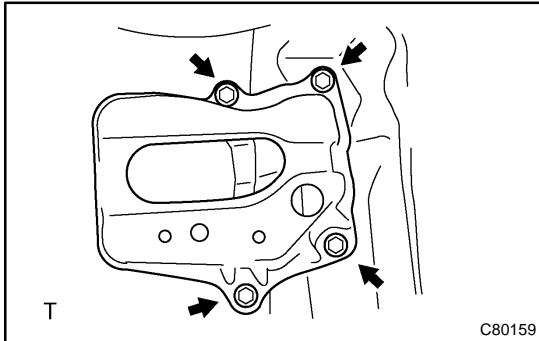
52. INSTALL CRUISE CONTROL ACTUATOR ASSY (W/ CRUISE CONTROL) (See page 82-4)**53. INSTALL BATTERY CARRIER**

(a) Install the battery carrier and 4 bolts.

Torque: 13 N·m (133 kgf·cm, 10 ft·lbf)**54. INSTALL BATTERY TRAY****55. INSTALL BATTERY****56. INSTALL BATTERY CLAMP SUB-ASSY**

Torque:

Bolt: 5.0 N·m (51 kgf·cm, 44 in·lbf)**Nut: 3.5 N·m (36 kgf·cm, 31 in·lbf)****57. INSTALL AIR CLEANER ASSY**

Torque: 7.0 N·m (71 kgf·cm, 62 in·lbf)

58. INSTALL CYLINDER HEAD COVER NO.2

Torque: 7.0 N·m (71 kgf·cm, 62 in·lbf)

59. INSTALL HOOD SUB-ASSY

Torque: 13 N·m (133 kgf·cm, 10 ft·lbf)

60. INSPECT HOOD SUB-ASSY**61. ADJUST HOOD SUB-ASSY (See page 75-1)****62. ADD TRANSAXLE OIL (See page 41-2)****63. INSPECT TRANSAXLE OIL (See page 41-2)****64. BLEED POWER STEERING FLUID (See page 51-3)****65. INSTALL FRONT WHEELS**

Torque: 103 N·m (1,050 kgf·cm, 76 ft·lbf)

66. PLACE FRONT WHEELS FACING STRAIGHT AHEAD**67. INSTALL EXHAUST PIPE (See page 15-2)****68. INSTALL ENGINE UNDER COVER LH****69. INSTALL ENGINE UNDER COVER RH****70. INSPECT FRONT WHEEL ALIGNMENT (See page 26-5)****71. CHECK ABS SPEED SENSOR SIGNAL (See page 05-297)**

MANUAL TRANSAXLE ASSY (C59) COMPONENTS

4107E-01

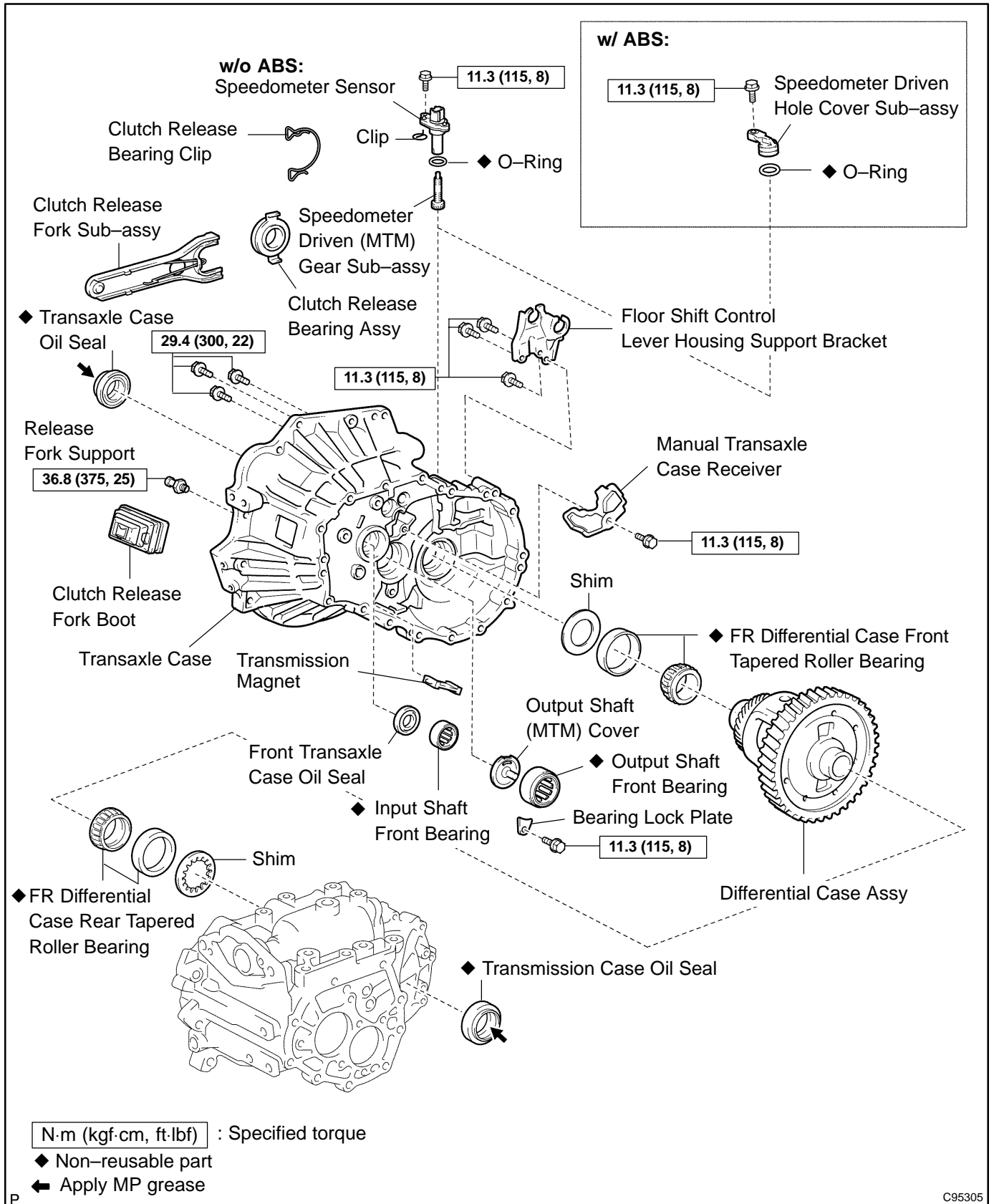

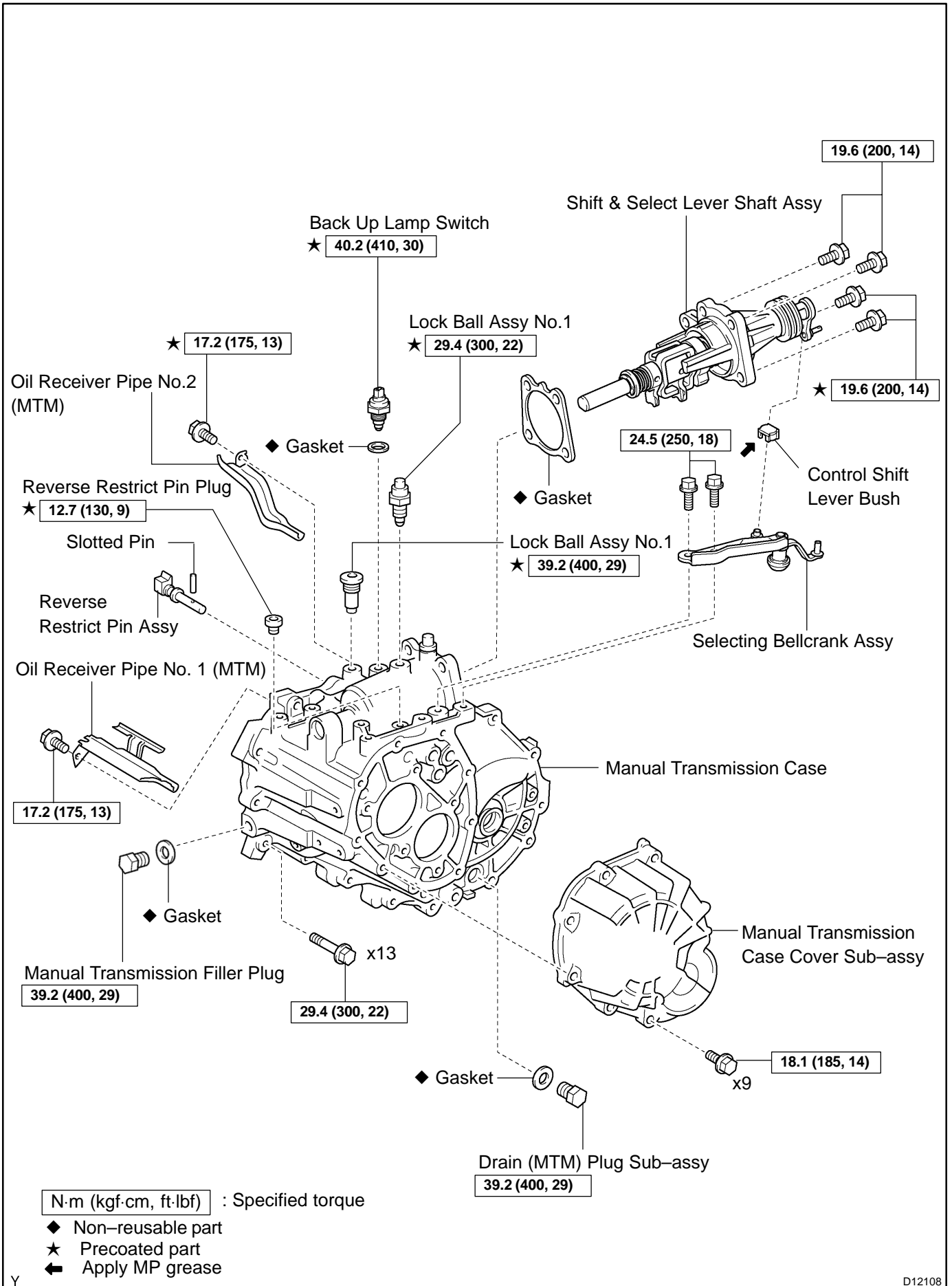

OVERHAUL

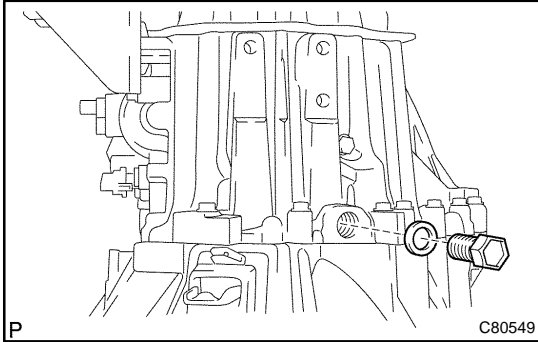

- 1. REMOVE MANUAL TRANSMISSION FILLER PLUG**
 - (a) Remove the manual transmission filler plug and gasket from the manual transmission case.

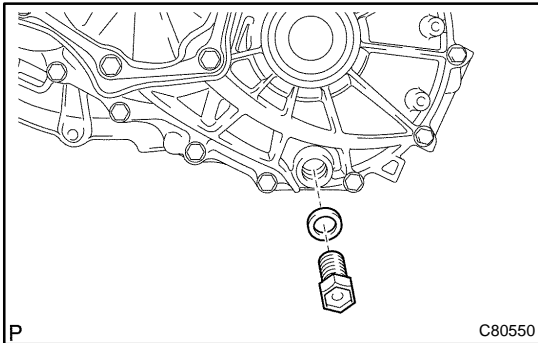

- 2. REMOVE DRAIN (MTM) PLUG SUB-ASSY**
 - (a) Remove the drain (MTM) plug sub-assy and gasket from the manual transmission case.

- 3. REMOVE SPEEDOMETER SENSOR (W/O ABS)**

- (a) Remove the bolt and speedometer sensor from the transaxle case.
- (b) Remove the O-ring from the speedometer sensor.

- 4. REMOVE SPEEDOMETER DRIVEN (MTM) GEAR SUB-ASSY (W/O ABS)**

- (a) Remove the clip and speedometer driven (MTM) gear sub-assy from the speedometer sensor.

- 5. REMOVE SPEEDOMETER DRIVEN HOLE COVER SUB-ASSY (W/ ABS)**

- (a) Remove the bolt and speedometer driven hole cover sub-assy from the transaxle case.
- (b) Remove the O-ring from the speedometer driven hole cover.

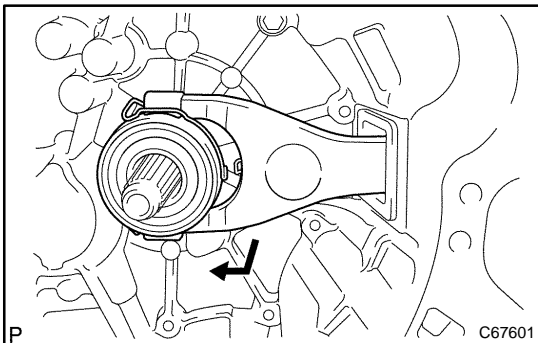

- 6. REMOVE CLUTCH RELEASE FORK SUB-ASSY**
 - (a) Remove the clutch release fork sub-assy with clutch release bearing assy from the transaxle case.

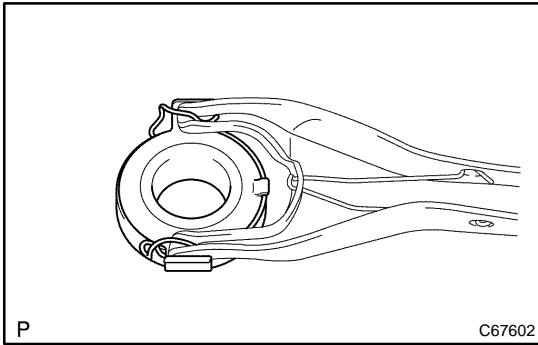

7. REMOVE CLUTCH RELEASE BEARING ASSY

- (a) Remove the clutch release bearing clip and clutch release bearing assy from the clutch release fork sub-assy.

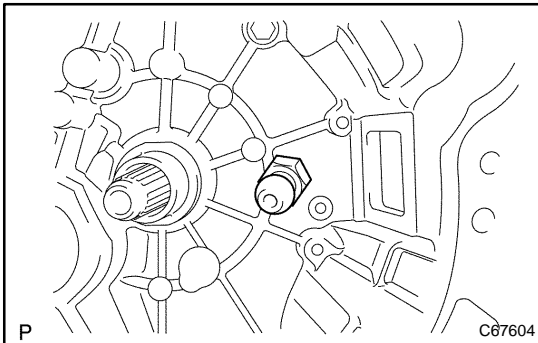

8. REMOVE RELEASE FORK SUPPORT

- (a) Remove the clutch release fork support from the transaxle case.

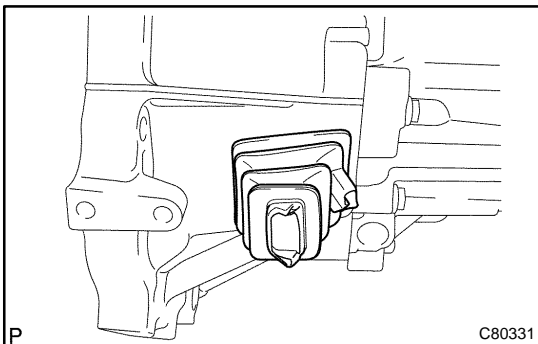

9. REMOVE CLUTCH RELEASE FORK BOOT

- (a) Remove the clutch release fork boot from the transaxle case.

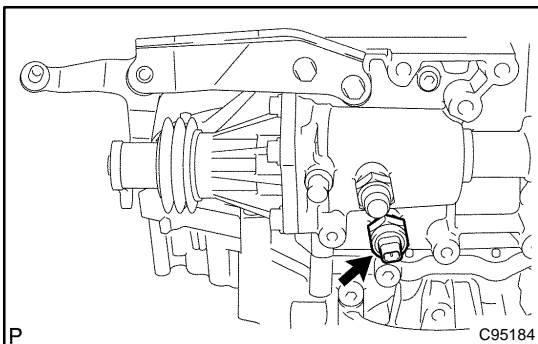

10. REMOVE BACK UP LAMP SWITCH ASSY

- (a) Remove the back up lamp switch assy and gasket from the manual transmission case.

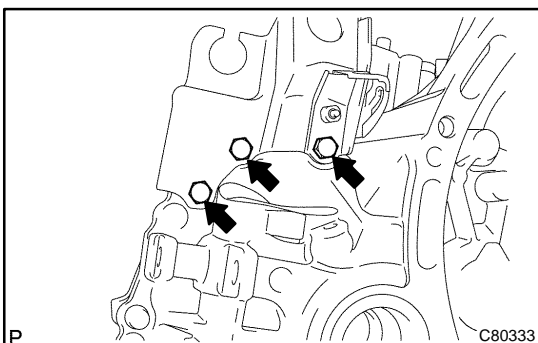

11. REMOVE FLOOR SHIFT CONTROL LEVER HOUSING SUPPORT BRACKET

- (a) Remove the 3 bolts and floor shift control lever housing support bracket from the transaxle case.

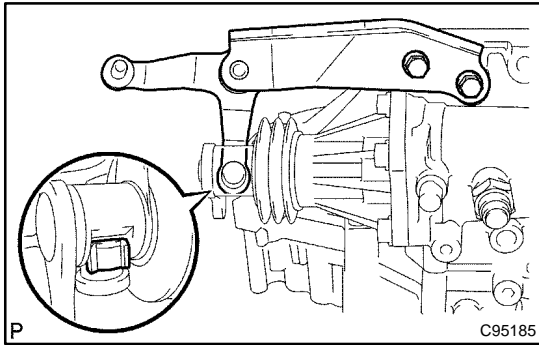
**12. REMOVE SELECTING BELL CRANK ASSY**

- (a) Remove the 2 bolts and selecting bellcrank assy from the manual transmission case.
- (b) Remove the control shift lever bush.

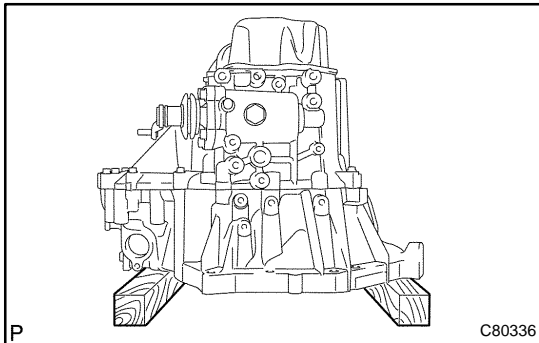
**13. FIX MANUAL TRANSAXLE ASSY**

- (a) Using 2 wooden blocks, fix the manual transaxle assy.

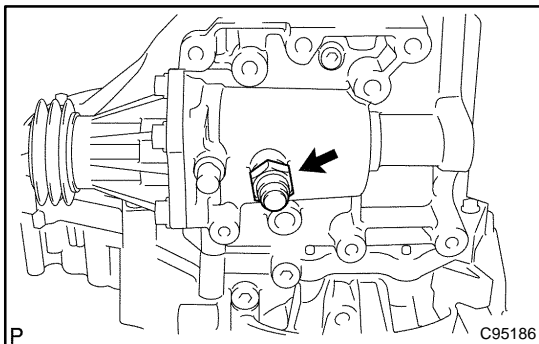
**14. REMOVE LOCK BALL ASSY NO.1**

- (a) Remove the lock ball assy No.1 from the manual transmission case.

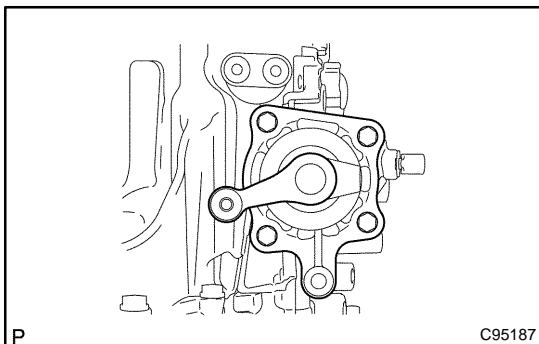
**15. REMOVE SHIFT & SELECT LEVER SHAFT ASSY**

- (a) Remove the 4 bolts, shift & select lever shaft assy and gasket from the manual transmission case.

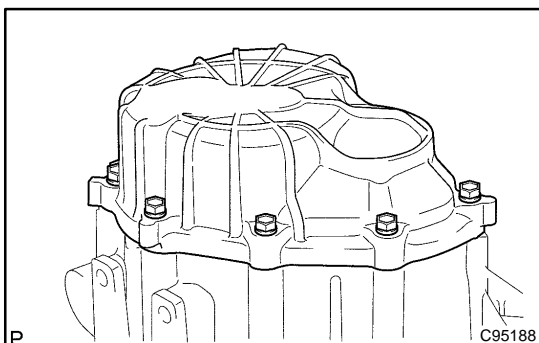
**16. REMOVE MANUAL TRANSMISSION CASE COVER SUB-ASSY**

- (a) Remove the 9 bolts.

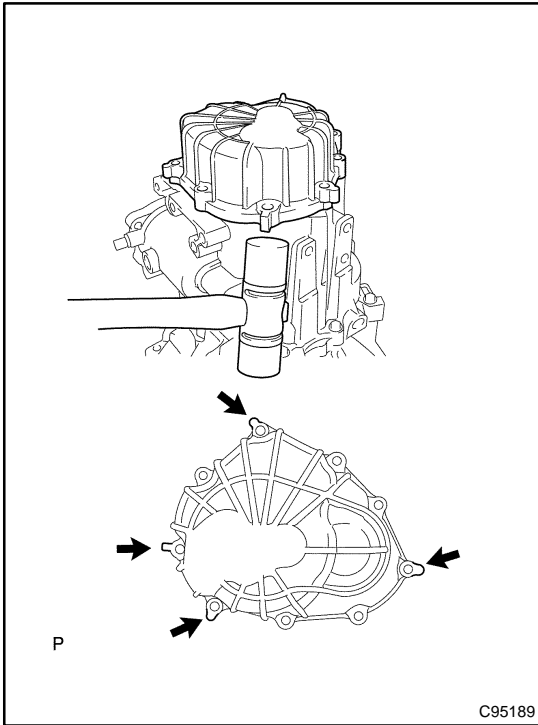

- (b) Using a plastic hammer, carefully tap the projection of the manual transmission case cover sub-assy to remove it from the manual transmission case.

NOTICE:

Do not damage the manual transmission case.

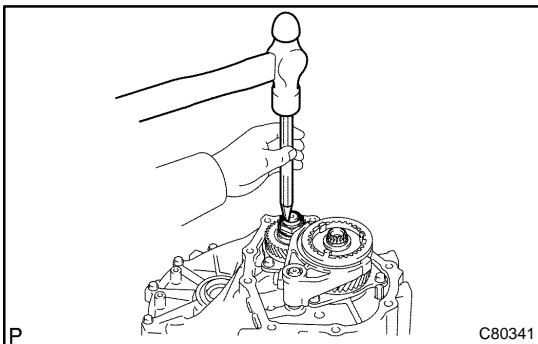

17. REMOVE MANUAL TRANSMISSION OUTPUT SHAFT REAR SET NUT

- (a) Using a chisel and a hammer, loosen the staked part of the manual transmission output shaft rear set nut.

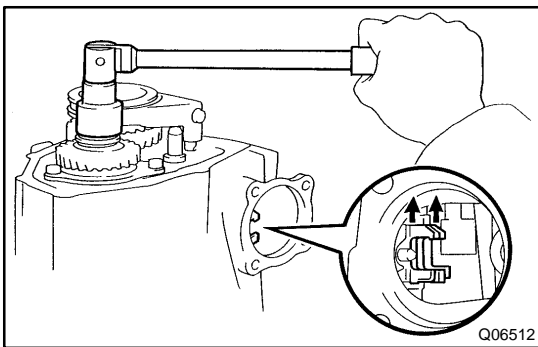

- (b) Engage the gear to the double meshing.
 (c) Remove the manual transmission output shaft rear set nut.
 (d) Disengage the double meshing of the gear.

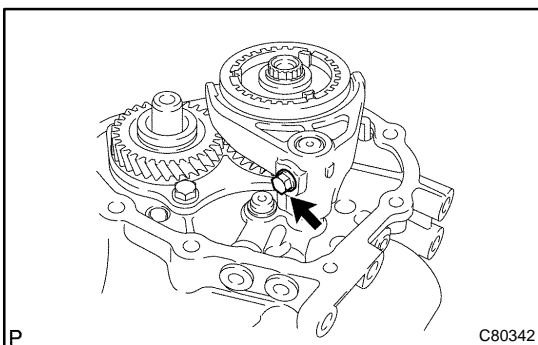

18. REMOVE GEAR SHIFT FORK NO.3

- (a) Remove the gear shift fork lock bolt from the gear shift fork No.3.

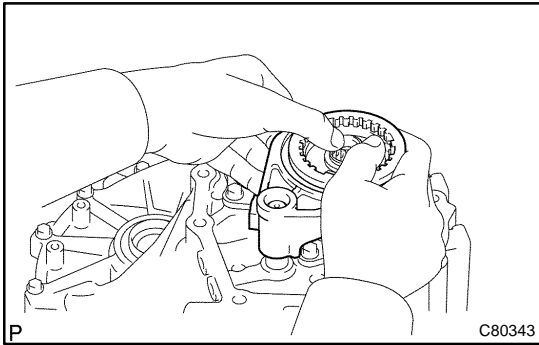

- (b) Remove the transmission hub sleeve No.3 with gear shift fork No.3 from the transmission clutch hub No.3.

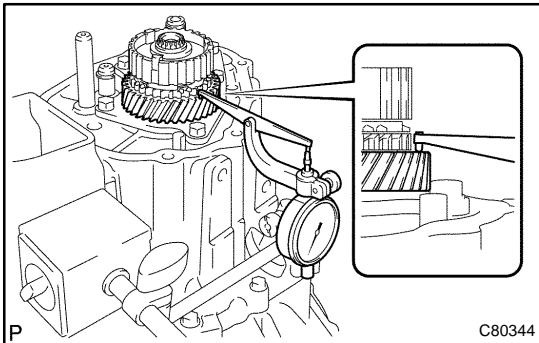

19. INSPECT 5TH GEAR THRUST CLEARANCE

- (a) Using a dial indicator, measure the 5th gear thrust clearance.

5th gear thrust clearance:

Standard clearance: mm (in.)	Maximum clearance: mm (in.)
0.10 – 0.57 (0.0039 – 0.0224)	0.57 (0.0224)

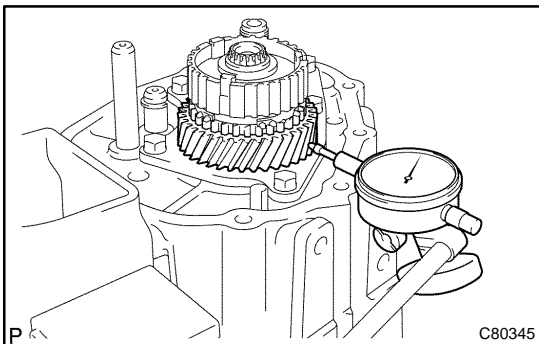

20. INSPECT 5TH GEAR RADIAL CLEARANCE

- (a) Using a dial indicator, measure the 5th gear radial clearance.

5th gear radial clearance: mm (in.)

Standard clearance: mm (in.)	Maximum clearance: mm (in.)
KOYO made: 0.015 – 0.058 (0.0006 – 0.0023)	KOYO made: 0.058 (0.0023)
NSK made: 0.015 – 0.056 (0.0006 – 0.0022)	NSK made: 0.056 (0.0022)

If the clearance exceeds the maximum, replace the gear, needle roller bearing or shaft.

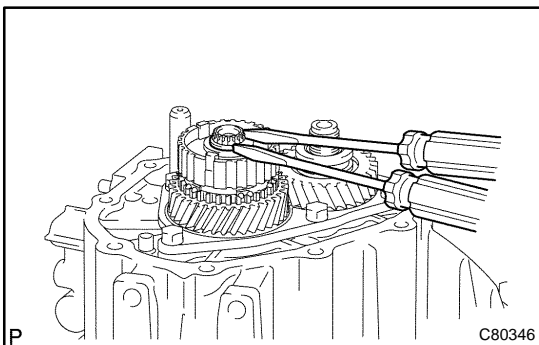

21. REMOVE TRANSMISSION CLUTCH HUB NO.3

- (a) Using 2 screwdrivers and a hammer, tap out the snap ring.

HINT:

Using a waste to prevent the snap ring from being scattered.

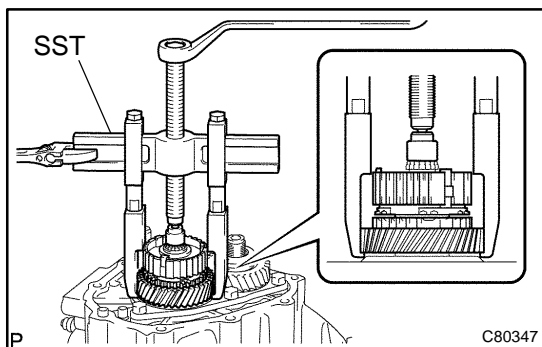

- (b) Using SST, remove the transmission clutch hub No.3, 5th gear and synchronizer ring No.3 from the input shaft.
 SST 09950-40011 (09951-04020, 09952-04010, 09953-04030, 09954-04010, 09955-04071, 09957-04010), 09950-60010 (09951-00200)

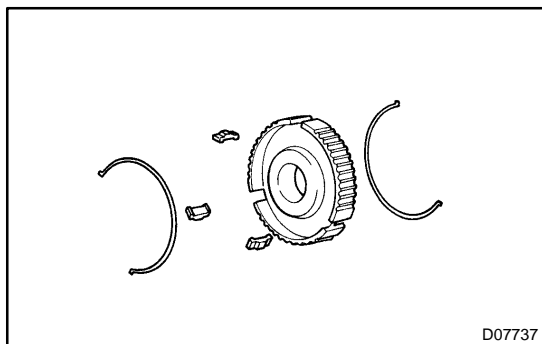

- (c) Remove the 3 synchromesh shifting keys and 2 synchromesh shifting key springs from the transmission clutch hub No.3.

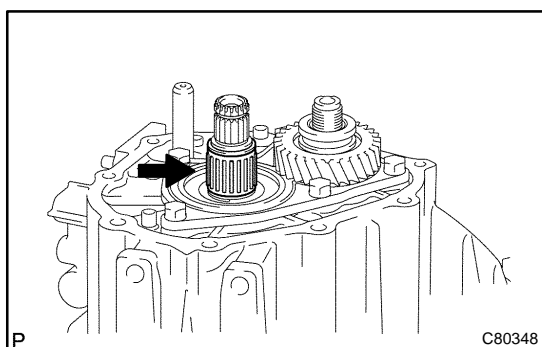

22. REMOVE 5TH GEAR NEEDLE ROLLER BEARING

- (a) Remove the 5th gear needle roller bearing and 5th gear bearing spacer from the input shaft.

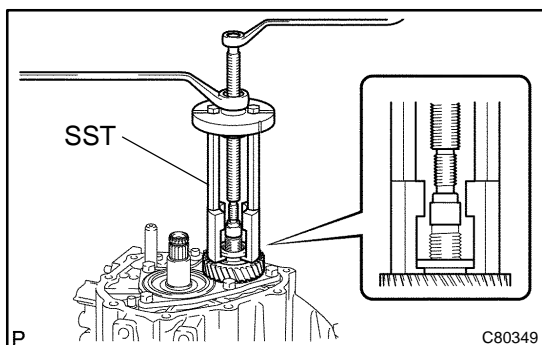

23. REMOVE 5TH DRIVEN GEAR

- (a) Using SST, remove the 5th driven gear from the output shaft.
 SST 09950-30012 (09951-03010, 09953-03010, 09954-03010, 09955-03011, 09957-04010), 09950-60010 (09951-00190)

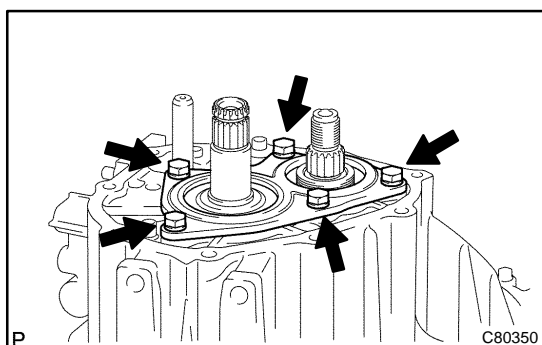

24. REMOVE BEARING RETAINER REAR (MTM)

- (a) Remove the 5 bolts and bearing retainer rear (MTM) from the manual transmission case.

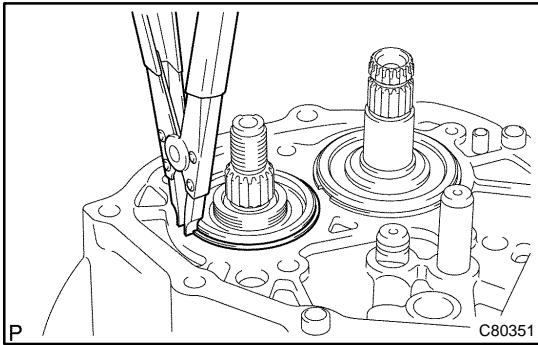

25. REMOVE OUTPUT SHAFT REAR BEARING HOLE SNAP RING

- (a) Using a snap ring expander, remove the output shaft rear bearing hole snap ring from the output shaft.

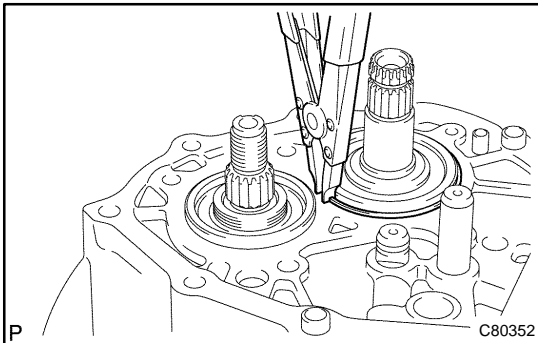

26. REMOVE INPUT SHAFT REAR BEARING HOLE SNAP RING

- (a) Using a snap ring expander, remove the input shaft rear bearing hole snap ring from the input shaft.

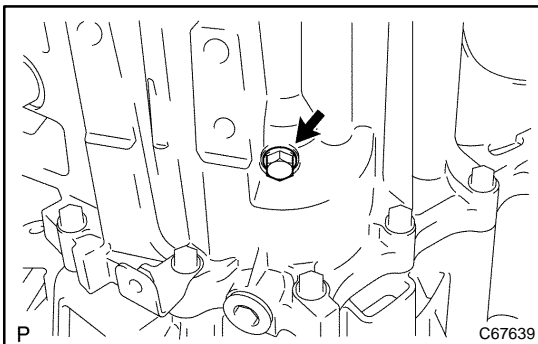

27. REMOVE REVERSE IDLER GEAR SHAFT BOLT

- (a) Remove the reverse idler gear shaft bolt and gasket from the manual transmission case.

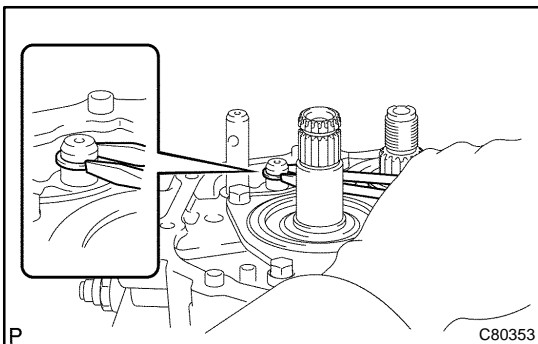

28. REMOVE SHIFT FORK SHAFT SHAFT SNAP RING

- (a) Using 2 screwdrivers and a hammer, tap out the snap ring from the gear shift fork shaft No.2.

HINT:

Using a waste to prevent the snap ring from being scattered.

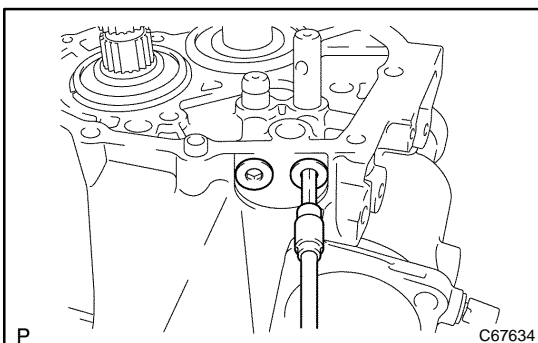

29. REMOVE SHIFT DETENT BALL

- (a) Using a hexagon wrench, remove the 2 shift detent ball plugs from the manual transmission case.

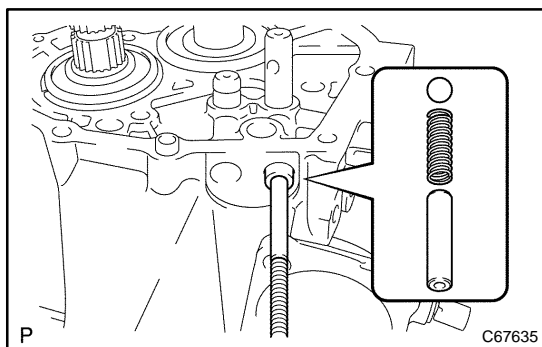

- (b) Using a magnetic finger, remove the 2 seats, 2 springs and 2 shift detent balls from the manual transmission case.

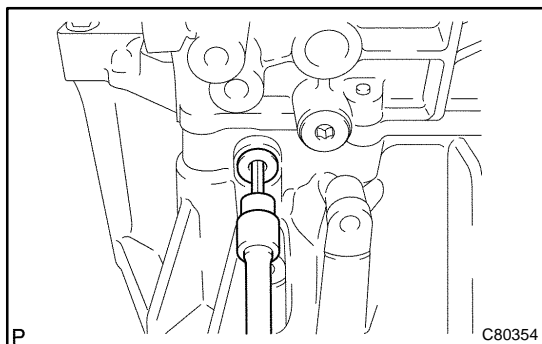

- (c) Using a hexagon wrench, remove the shift detent ball plug from the transaxle case.

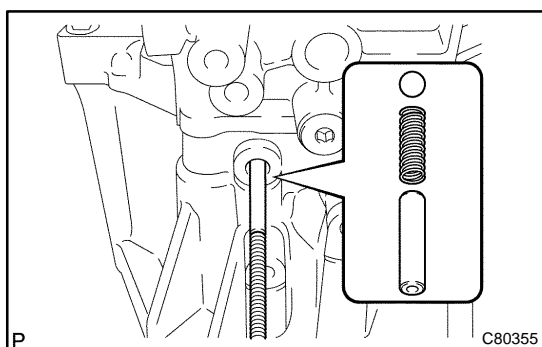

- (d) Using a magnetic finger, remove the seat, spring and shift detent ball from the transaxle case.

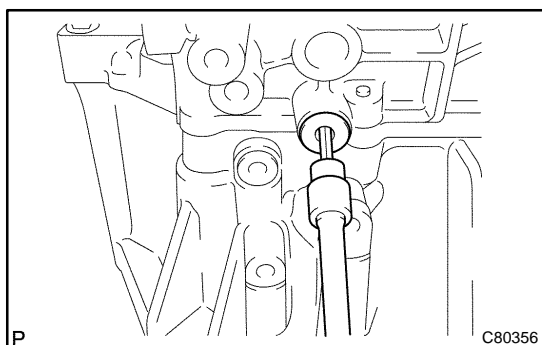

30. REMOVE LOCK BALL ASSY NO.1

- (a) Using a hexagon wrench, remove the lock ball assy No.1 from the manual transmission case.

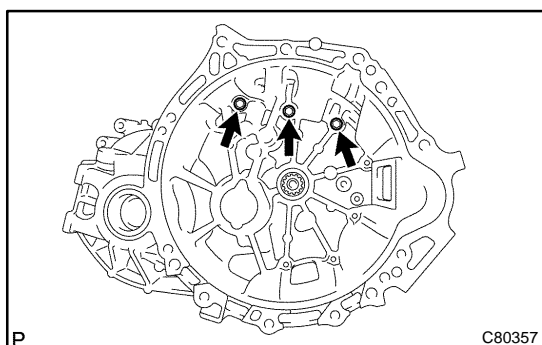

31. REMOVE MANUAL TRANSMISSION CASE

- (a) Remove the 3 bolts from the transaxle case side.

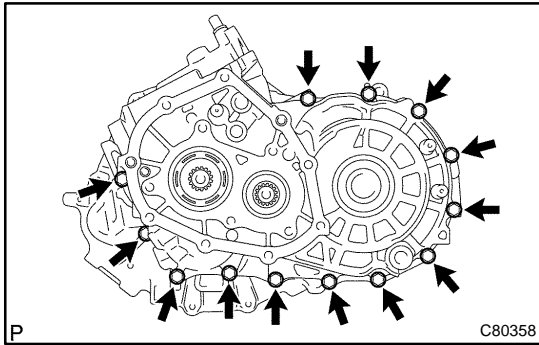

- (b) Remove the 13 bolts from the manual transmission case side.



- (c) Using a brass bar and a hammer, carefully tap the projection of the manual transmission case to remove it from the transaxle case.

NOTICE:

Do not damage the manual transmission case and transaxle case.

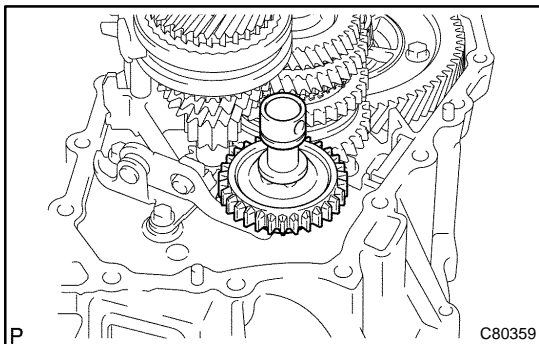

32. REMOVE REVERSE IDLER GEAR SUB-ASSY

- (a) Remove the reverse idler gear sub-assy, thrust washer and reverse idler gear shaft from the transaxle case.

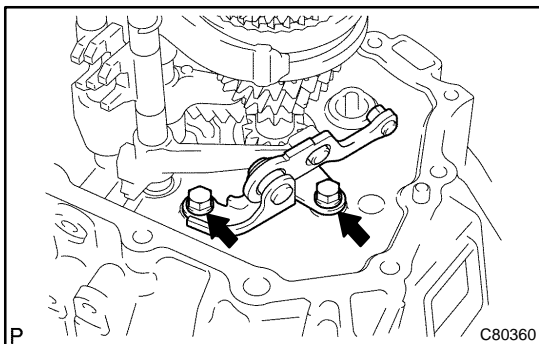

33. REMOVE REVERSE SHIFT ARM BRACKET ASSY

- (a) Remove the 2 bolts and reverse shift arm bracket assy from the transaxle case.

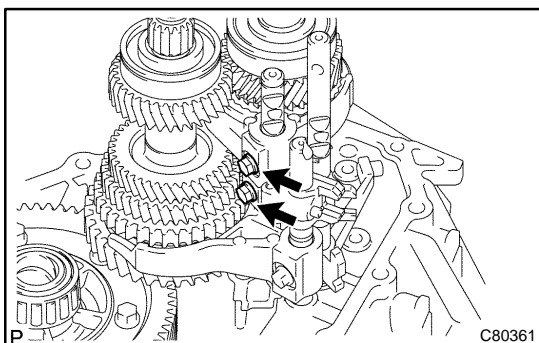

34. REMOVE GEAR SHIFT FORK SHAFT NO.2

- (a) Remove the 2 bolts from the gear shift fork No. 2 and gear shift head No.1.

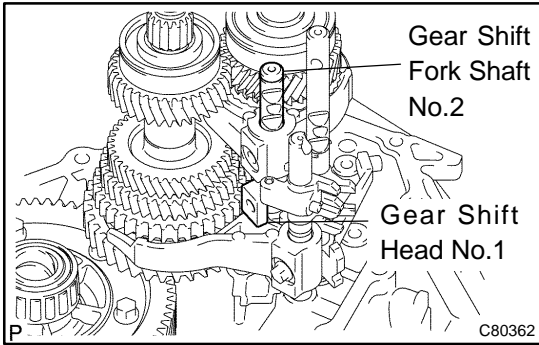

- (b) Remove the gear shift fork shaft No.2 and gear shift head No.1 from the transaxle case.

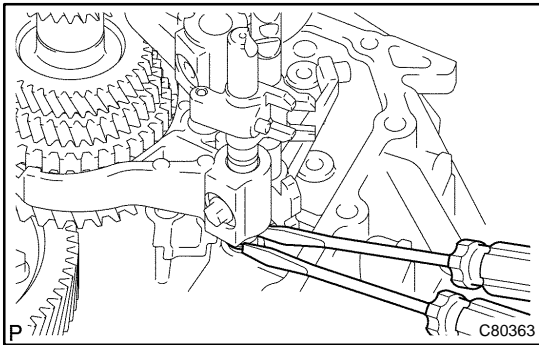

35. REMOVE GEAR SHIFT FORK SHAFT SUB-ASSY NO.1

- (a) Using 2 screwdrivers and a hammer, tap out the snap rings.

HINT:

Using a waste to prevent the snap ring from being scattered.

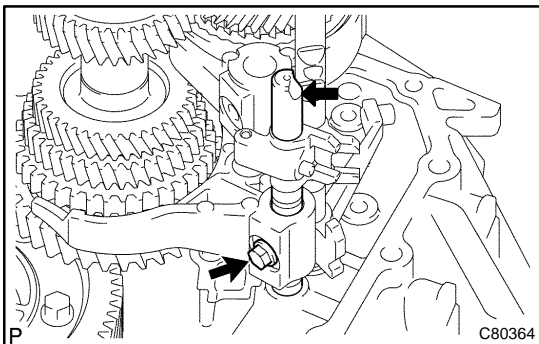

- (b) Remove the gear shift fork lock bolt and gear shift fork shaft sub-assy No.1 from the gear shift fork No.1.

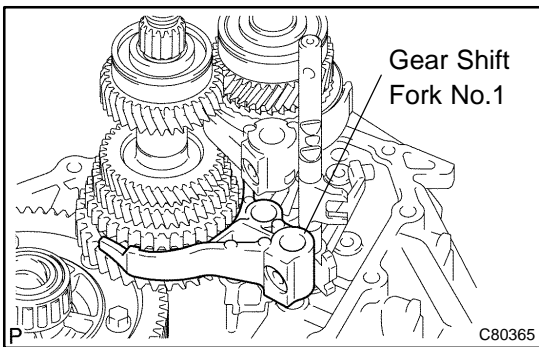

- (c) Remove the gear shift fork No.1.

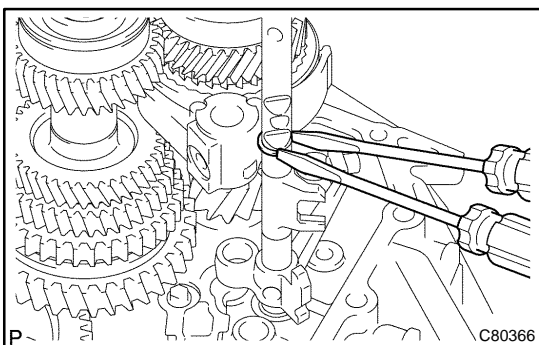

36. REMOVE GEAR SHIFT FORK SHAFT NO.3

- (a) Using 2 screwdrivers and a hammer, tap out the snap ring from the gear shift fork shaft No.3.

HINT:

Using a waste to prevent the snap ring from being scattered.

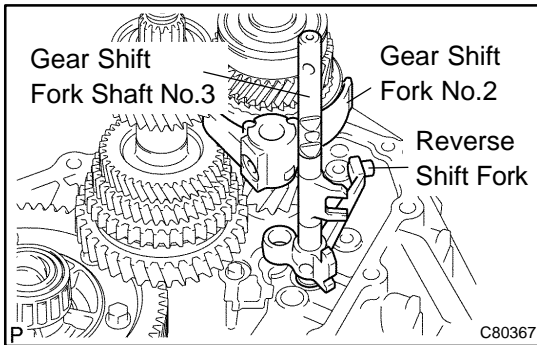

- (b) Remove the shift fork shaft No.3 with reverse shift fork and gear shift fork No.2 from the transaxle case.

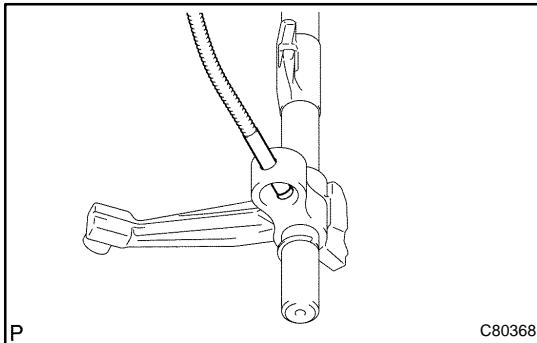

- (c) Using a magnetic finger, remove the 2 balls from the reverse shift fork.

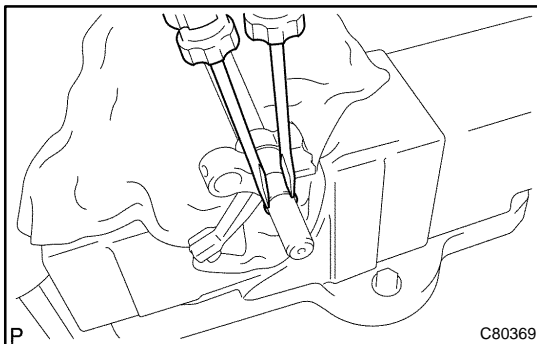

- (d) Using 2 screwdrivers and a hammer, tap out the snap ring.

HINT:

Using a waste to prevent the snap ring from being scattered.

- (e) Remove the reverse shift fork from the gear shift fork shaft No.3.

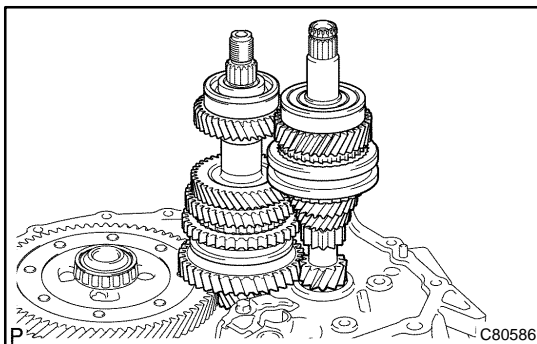

37. REMOVE INPUT SHAFT ASSY

- (a) Remove the input and output shaft assy from the transaxle case.

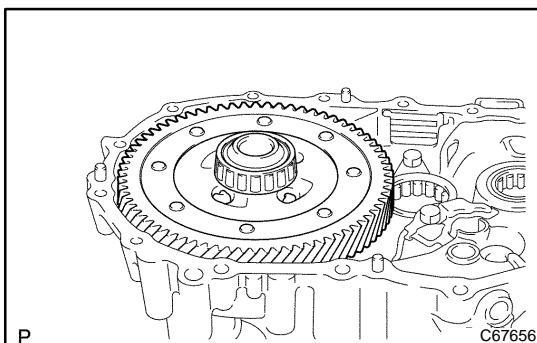

38. REMOVE DIFFERENTIAL CASE ASSY

- (a) Remove the differential case assy from the transaxle case.

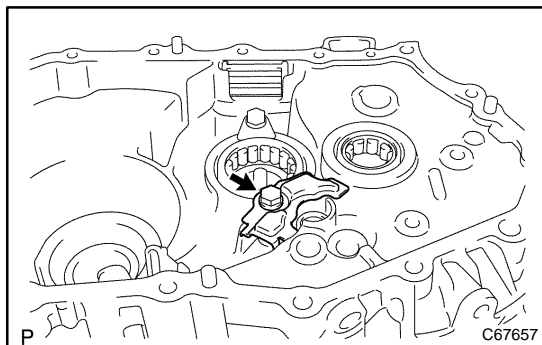
**39. REMOVE MANUAL TRANSAXLE CASE RECEIVER**

- (a) Remove the bolt and manual transaxle case receiver from the transaxle case.

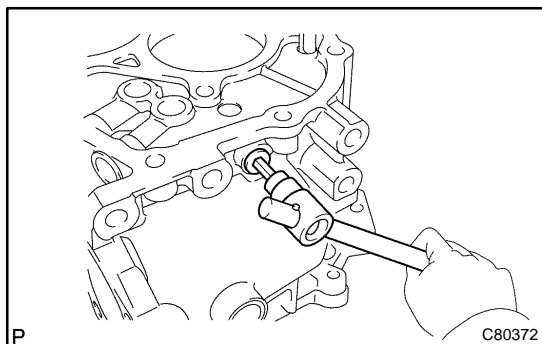
**40. REMOVE REVERSE RESTRICT PIN ASSY**

- (a) Using a hexagon wrench, remove the reverse restrict pin plug from the manual transmission case.

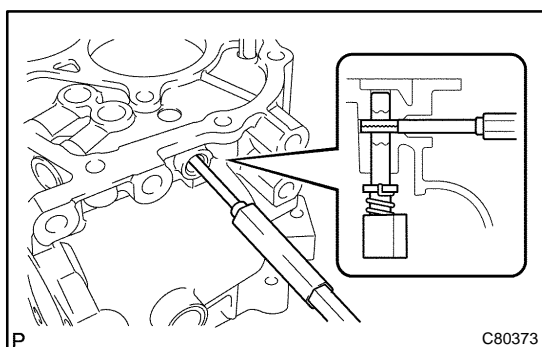

- (b) Using a pin punch (ϕ 5 mm) and a hammer, drive out the slotted spring pin and remove the reverse restrict pin assy from the manual transmission case.

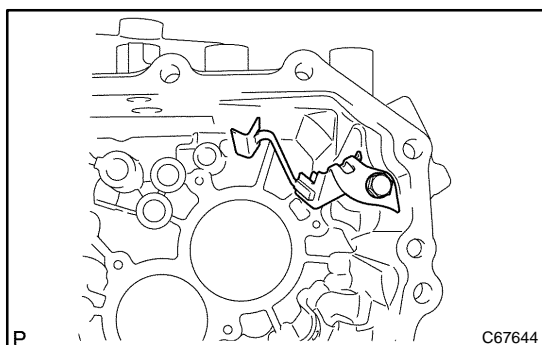
**41. REMOVE OIL RECEIVER PIPE NO.1 (MTM)**

- (a) Remove the bolt and oil receiver pipe No.1 (MTM) from the manual transmission case.

NOTICE:

Be careful not to damage the oil receiver pipe No.1 (MTM).

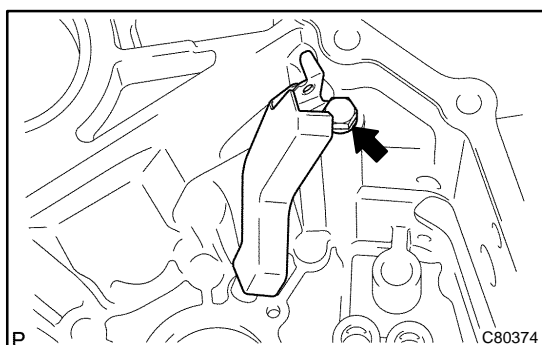
**42. REMOVE OIL RECEIVER PIPE NO.2 (MTM)**

- (a) Remove the bolt and oil receiver pipe No.2 (MTM) from the manual transmission case.

NOTICE:

Be careful not to damage the oil receiver pipe No.2 (MTM).

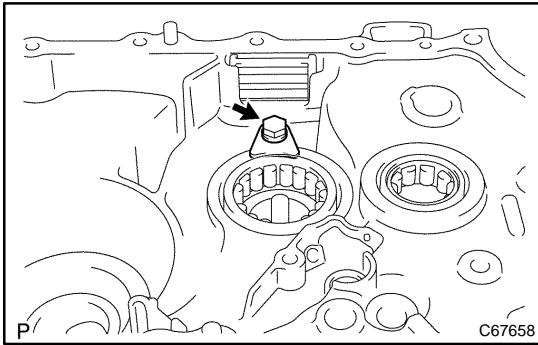
**43. REMOVE BEARING LOCK PLATE**

- (a) Remove the bolt and bearing lock plate from the transaxle case.

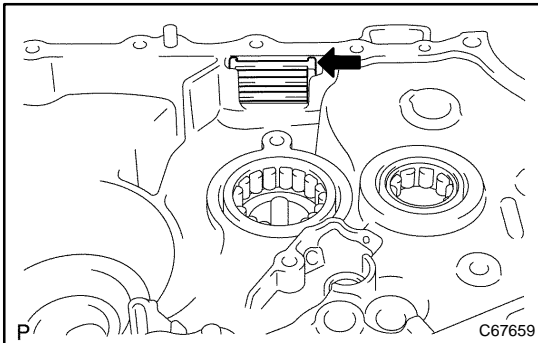
**44. REMOVE TRANSMISSION MAGNET**

- (a) Remove the transmission magnet from the transaxle case.

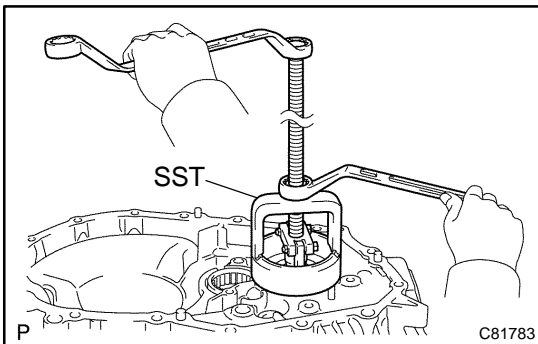
**45. REMOVE INPUT SHAFT FRONT BEARING**

- (a) Using SST, remove the input shaft front bearing from the transaxle case.

SST 09612-65014 (09612-01050, 09612-01060)

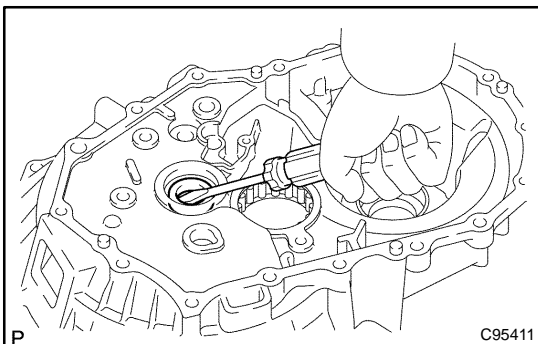
**46. REMOVE FRONT TRANSAXLE CASE OIL SEAL**

- (a) Using a screwdriver, remove the front transaxle case oil seal from the transaxle case.

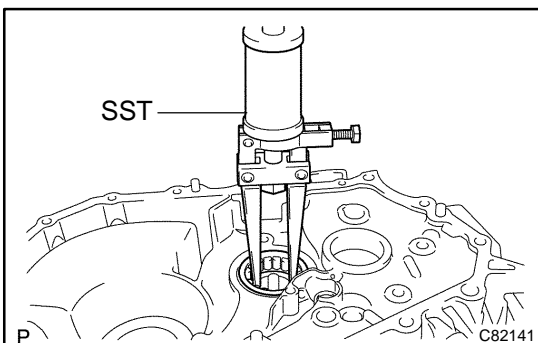
**47. REMOVE OUTPUT SHAFT FRONT BEARING**

- (a) Using SST, remove the output shaft front bearing from the transaxle case.

SST 09308-00010

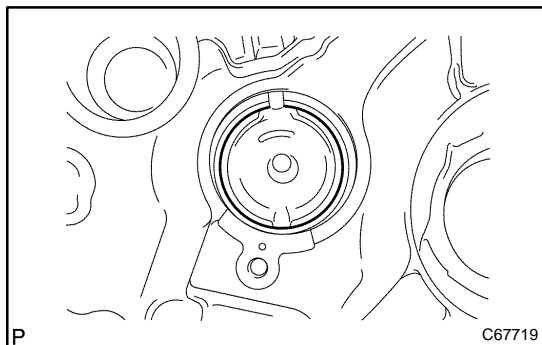
**48. REMOVE OUTPUT SHAFT (MTM) COVER**

- (a) Remove the output shaft (MTM) cover from the transaxle case.

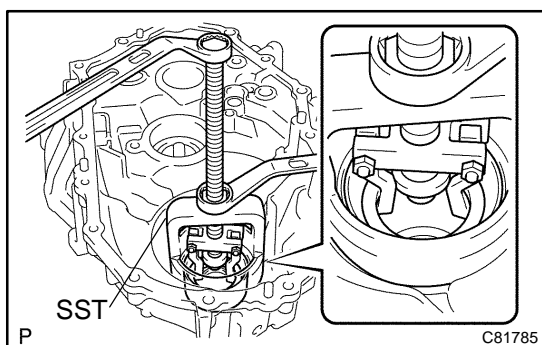
**49. REMOVE FR DIFFERENTIAL CASE FRONT TAPERED ROLLER BEARING**

- (a) Using SST, remove the FR differential case front tapered roller bearing (outer race) and shim from the transaxle case.

SST 09612-65014 (09612-01040, 09612-01050)

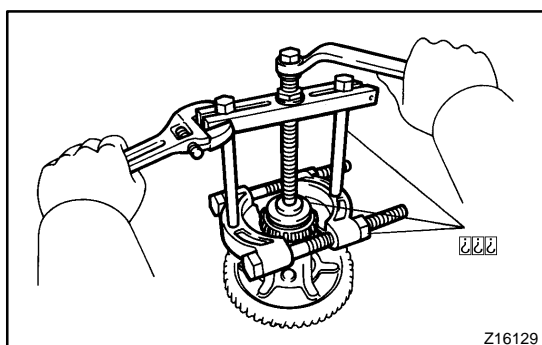

- (b) Using SST, remove FR differential case front tapered roller bearing (inner race) from the front differential case.

SST 09950-00020, 09950-00030, 09950-40011
(09957-04010), 09950-60010 (09951-00360)

NOTICE:

Be careful not to damage bearing.

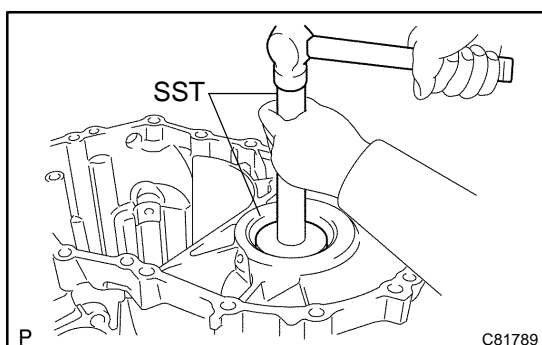
**50. REMOVE TRANSAXLE CASE OIL SEAL**

- (a) Using SST and a hammer, drive out the transaxle case oil seal from the transaxle case.

SST 09950-60010 (09951-00530), 09950-70010
(09951-07150)

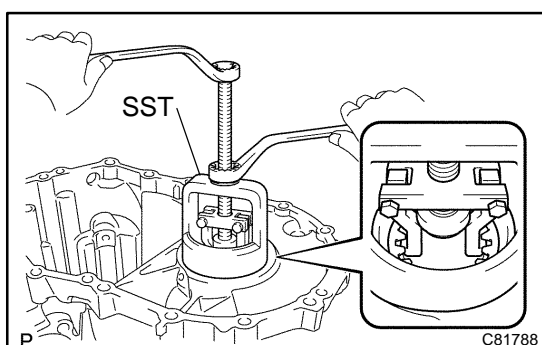
**51. REMOVE FR DIFFERENTIAL CASE REAR TAPERED ROLLER BEARING**

- (a) Using SST, remove the FR differential case rear tapered roller bearing (outer race) and shim from the manual transmission case.

SST 09612-65014 (09612-01040, 09612-01050)

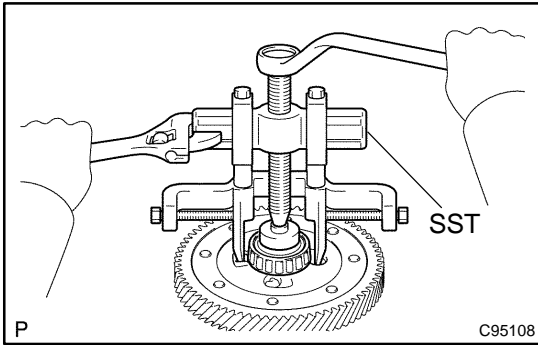

- (b) Using SST and a hammer, remove the FR differential case rear tapered roller bearing (inner race) from the front differential case.

SST 09950-40011 (09951-04010, 09952-04010, 09953-04020, 09954-04010, 09955-04061, 09957-04010, 09958-04011), 09950-60010 (09951-00360)

NOTICE:

Be careful not to damage bearing.

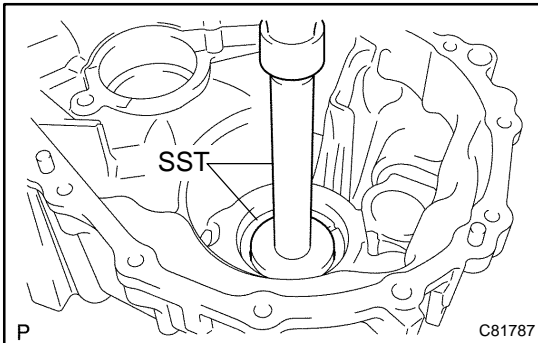

52. REMOVE TRANSMISSION CASE OIL SEAL

- (a) Using SST and a hammer, remove the transmission case oil seal from the manual transmission case.

SST 09950-60010 (09951-00600), 09950-70010 (09951-07100)

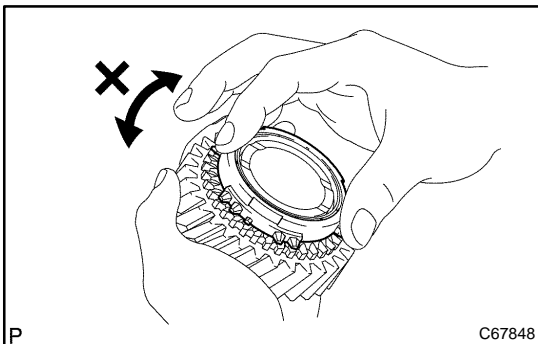

53. INSPECT SYNCHRONIZER RING NO.3

- (a) Check for wear or damage.
 (b) Check the braking effect of the synchronizer ring. Turn the synchronizer ring in one direction while pushing it to the gear cone, check that the ring locks.

If the braking effect is insufficient, apply a small amount of the fine lapping compound between the synchronizer ring and gear cone. Lightly rub the synchronizer ring and gear cone together.

NOTICE:

Ensure the file lapping compound is completely washed off after rubbing.

- (c) Check again the braking effect of the synchronizer ring.

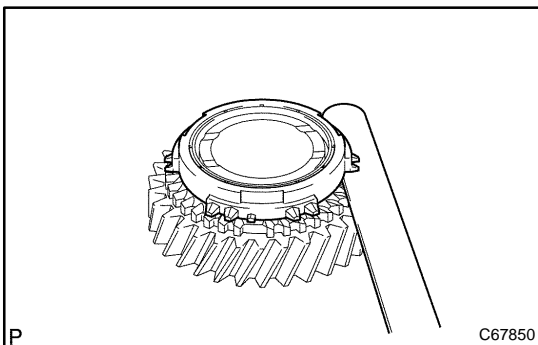

- (d) Using a feeler gauge, measure the clearance between the synchronizer ring back and gear spline end.

Minimum clearance: 0.75 mm (0.0295 in.)

If the clearance is less than minimum, replace the synchronizer ring and gear cone by applying a small amount of the fine lapping compound on gear cone.

NOTICE:

Ensure the fine lapping compound is completely washed off after rubbing.

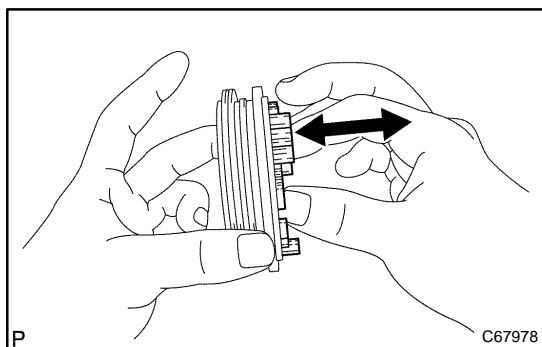
**54. INSPECT TRANSMISSION HUB SLEEVE NO.3**

- (a) Check the sliding condition between the transmission hub sleeve No. 3 and transmission clutch hub No.3.
- (b) Check that spline gear's of the transmission hub sleeve No.3 is not worn down.

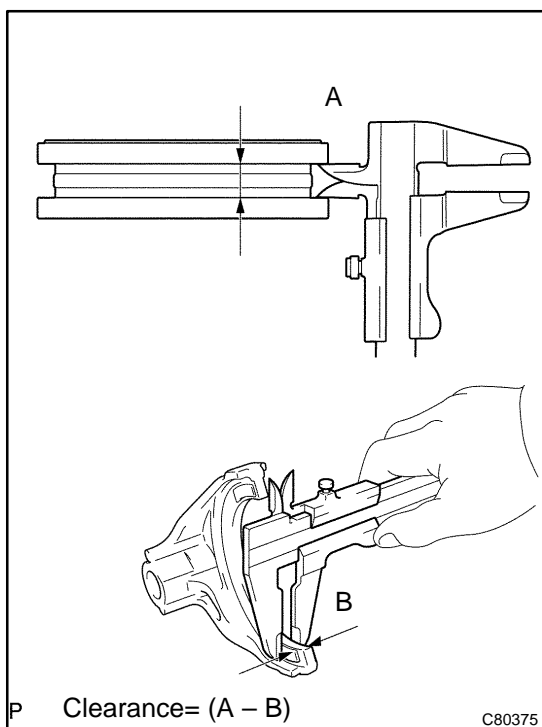

- (c) Using a vernier calipers, inspect the transmission hub sleeve No.3 and gear shift fork No.3 as shown in the illustration.

Standard clearance:**0.3 – 0.5 mm (0.012 – 0.020 in.)**

If the clearance is out of specification, replace the transmission hub sleeve No.3 and gear shift fork No.3.

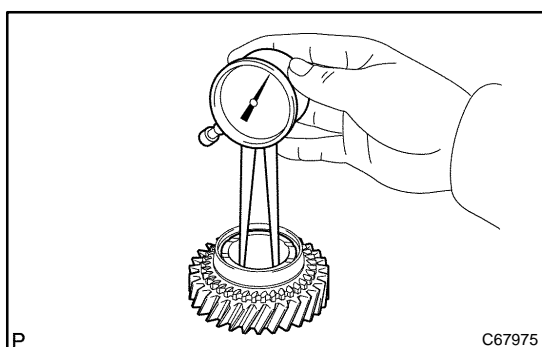
**55. INSPECT 5TH GEAR**

- (a) Using a caliper gauge, inspect 5th gear as shown in the illustration.

5th gear inner diameter:

Standard inner diameter: mm (in.)	Maximum inner diameter: mm (in.)
29.915 – 29.931 (1.1778 – 1.1783)	29.931 (1.1783)

If the inner diameter exceeds the maximum, replace the 5th gear.

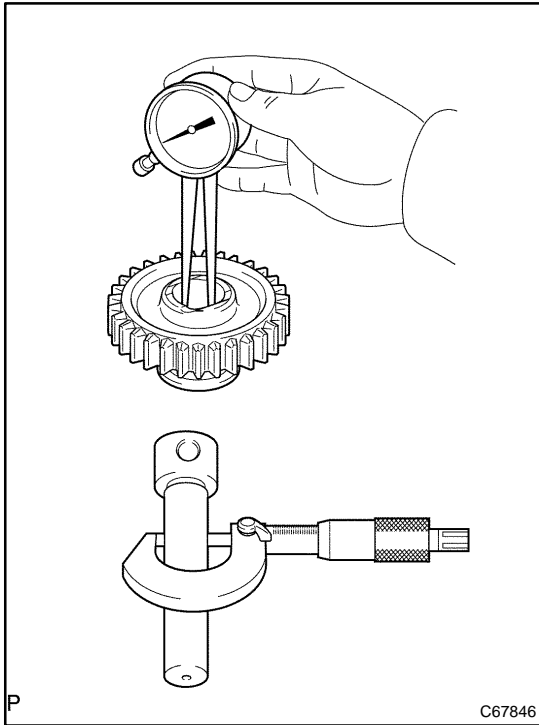
**56. INSPECT REVERSE IDLER GEAR SUB-ASSY**

- (a) Using a caliper gauge, inspect the reverse idler gear sub-assy as shown in the illustration.

Reverse idler gear sub-assy inner diameter:

Standard inner diameter: mm (in.)	Maximum inner diameter: mm (in.)
18.040 – 18.058 (0.7102 – 0.7109)	18.058 (0.7109)

If the inner diameter exceeds the maximum, replace the reverse idler gear sub-assy.

- (b) Using a micrometer, inspect the reverse idler gear shaft as shown in the illustration.

Reverse idler gear shaft outer diameter:

Standard inner diameter: mm (in.)	Minimum outer diameter: mm (in.)
17.966 – 17.984 (0.7073 – 0.7080)	17.966 (0.7073)

If the outer diameter is below the minimum, replace the reverse idler gear shaft.

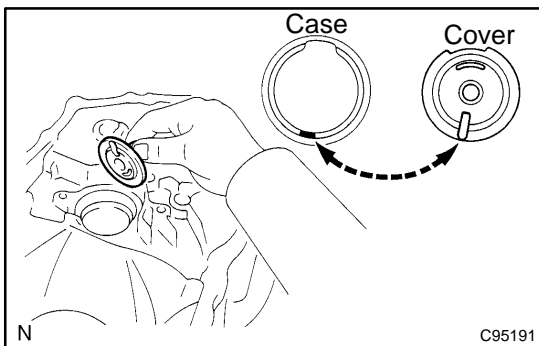
**57. INSTALL OUTPUT SHAFT (MTM) COVER**

- (a) Coat the output shaft (MTM) cover with MP grease, install it to the transaxle case.

NOTICE:

Install the output shaft (MTM) cover projection into the case side hollow.

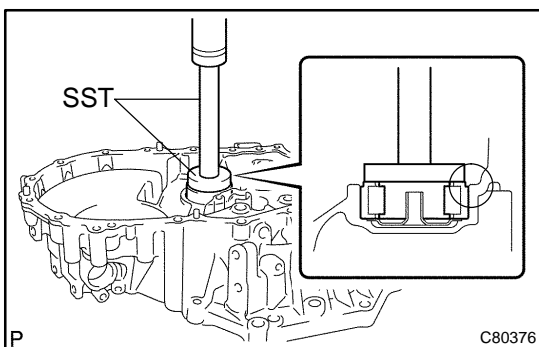
**58. INSTALL OUTPUT SHAFT FRONT BEARING**

- (a) Coat a new output shaft front bearing with gear oil, using SST and a press, install it to the transaxle case.

SST 09950-60010 (09951-00550), 09950-70010 (09951-07150)

NOTICE:

- Be sure to install a new bearing in the correct direction, as shown in the illustration.
- When replacing the output shaft front bearing, replace the output shaft front bearing inner race along with it.

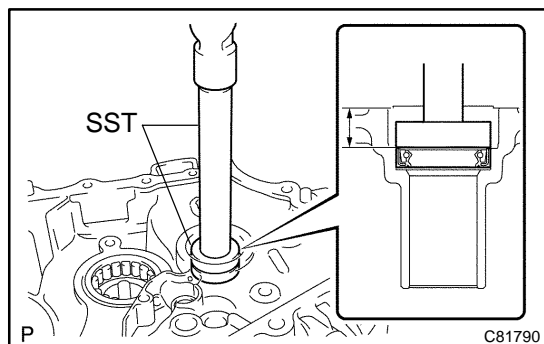
**59. INSTALL FRONT TRANSAXLE CASE OIL SEAL**

- (a) Using SST and a hammer, install a new front transaxle case oil seal to the transaxle case.
SST 09950-60010 (09951-00370), 09950-70010 (09951-07150)

Drive in depth: 15.6 – 16.0 mm (0.6142 – 0.6299 in.)

- (b) Coat the lip of the front transaxle case oil seal with MP grease.

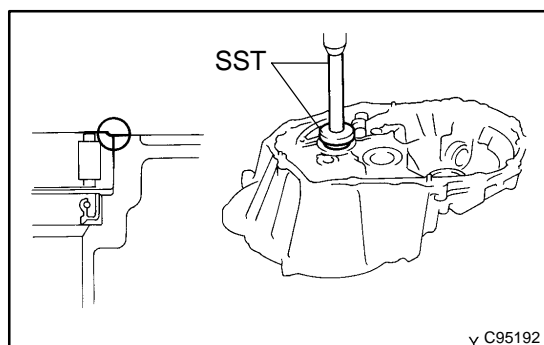
**60. INSTALL INPUT SHAFT FRONT BEARING**

- (a) Coat a new input shaft front bearing with MP grease, using SST and a press, install it to the transaxle case.
SST 09950-60010 (09951-00420), 09950-70010 (09951-07150)

Drive in depth: 0 – 0.3 mm (0 – 0.012 in.)

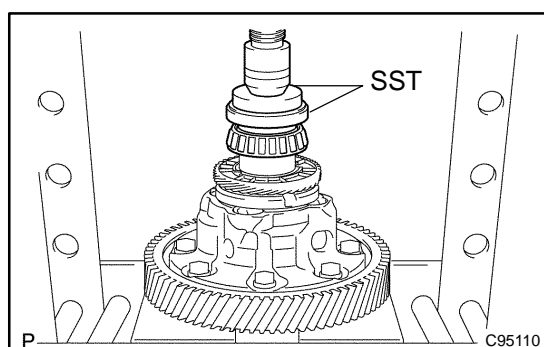
**61. INSTALL FR DIFFERENTIAL CASE FRONT TAPERED ROLLER BEARING**

- (a) Using SST and a press, install a new FR differential case front tapered roller bearing (inner race) to the front differential case.

SST 09350-32014 (09351-32120), 09950-60010 (09951-00530)

- (b) Using SST and a press, install a new FR differential case front tapered roller bearing (outer race) with shim to the transaxle case.

SST 09950-60020 (09951-00680), 09950-70010 (09951-07150)

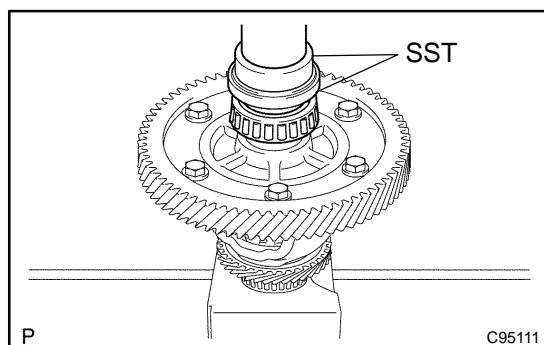
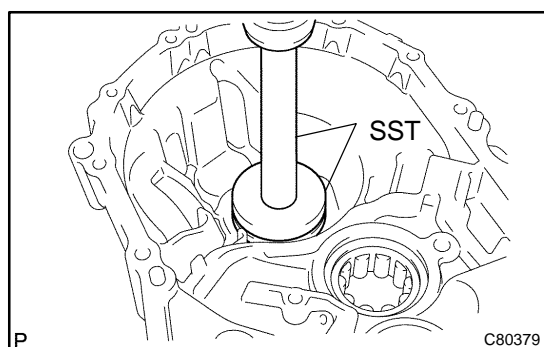
**62. INSTALL FR DIFFERENTIAL CASE REAR TAPERED ROLLER BEARING**

- (a) Using SST and a press, install a new FR differential case rear tapered roller bearing (inner race) to the front differential case.

SST 09350-32014 (09351-32120), 09950-60010 (09951-00530)

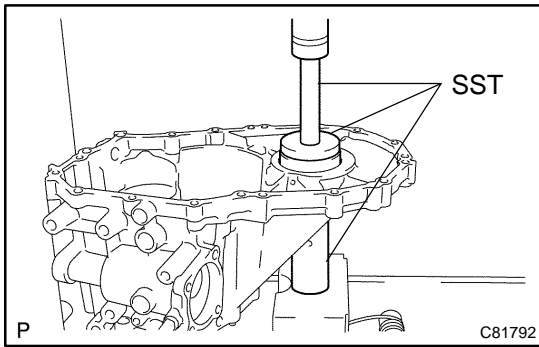

- (b) Using SST and a press, install a new FR differential case rear tapered roller bearing (outer race) with shim to the manual transmission case.

SST 09309-36010, 09950-60020 (09951-00710),
09950-70010 (09951-07150)

HINT:

Use a shim of the same thickness with the removed one.

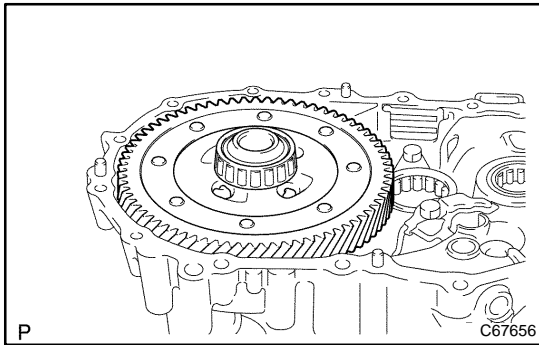

63. ADJUST DIFFERENTIAL SIDE BEARING RRELOAD

- (a) Coat the differential case assy with gear oil, install it to the transaxle case.

- (b) Install the manual transmission case with 16 bolts.

Torque: 29.4 N·m (300 kgf·cm, 22 ft·lbf)

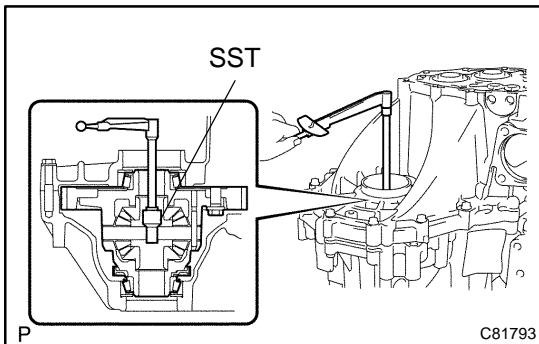

- (c) Using SST and a torque wrench, turn the differential case assy to the right and left 2 or 3 times to allow the bearings to settle.

SST 09564-32011

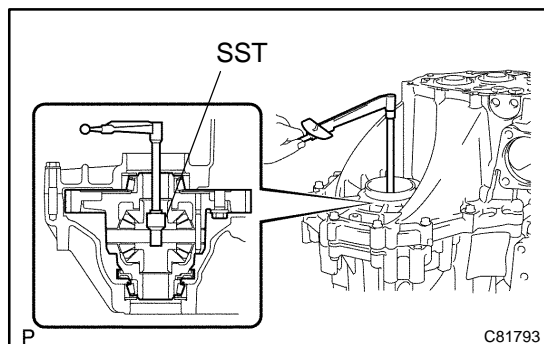

(d) Using SST and a torque wrench, measure the preload.

SST 09564-32011

Preload (at starting):

New bearing:

0.78 – 1.57 N·m (8 – 16 kgf·cm, 6.9 – 13.9 in.-lbf)

If the preload is out of specification, select another shim.

Shim thickness:

Mark	Thickness: mm (in.)	Mark	Thickness: mm (in.)
AA	2.10 (0.0827)	LL	2.60 (0.1024)
BB	2.15 (0.0846)	MM	2.65 (0.1043)
CC	2.20 (0.0866)	NN	2.70 (0.1063)
DD	2.25 (0.0886)	PP	2.75 (0.1083)
EE	2.30 (0.0906)	QQ	2.80 (0.1102)
FF	2.35 (0.0925)	RR	2.85 (0.1122)
GG	2.40 (0.0945)	SS	2.90 (0.1142)
HH	2.45 (0.0965)	TT	2.95 (0.1161)
JJ	2.50 (0.0984)	UU	3.00 (0.1181)
KK	2.55 (0.1004)	-	-

HINT:

The preload will change by about 0.3 – 0.4 N·m (3 – 4 kgf·cm, 2.6 – 3.5 in.-lbf) corresponding to a change of 0.05 mm (0.0020 in.) in shim thickness.

- (e) Remove the 16 bolts and manual transmission case from the transaxle case.
- (f) Remove the differential case assy from the transaxle case.

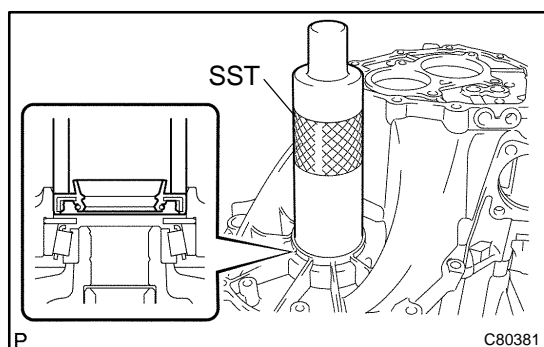

64. INSTALL TRANSMISSION CASE OIL SEAL

(a) Using SST and a hammer, install a new transmission case oil seal to the manual transmission case.

SST 09316-60011 (09316-00011)

Drive in depth: 9.9 ± 0.3 mm (0.390 ± 0.012 in.)

(b) Coat the lip of the transmission case oil seal with MP grease.

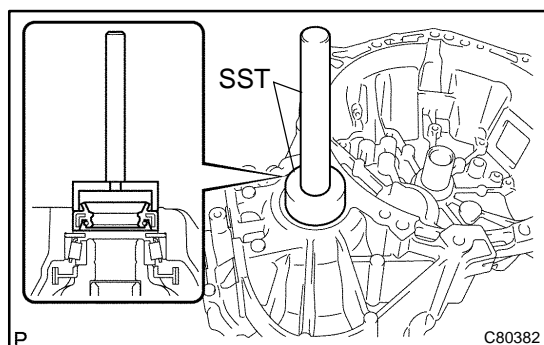

65. INSTALL TRANSAXLE CASE OIL SEAL

(a) Using SST and a hammer, install a new transaxle case oil seal in the transaxle case.

SST 09710-20011 (09710-06071), 09950-70010 (09951-07150)

Drive in depth: 1.9 ± 0.3 mm (0.075 ± 0.012 in.)

(b) Coat the lip of the transaxle case oil seal with MP grease.

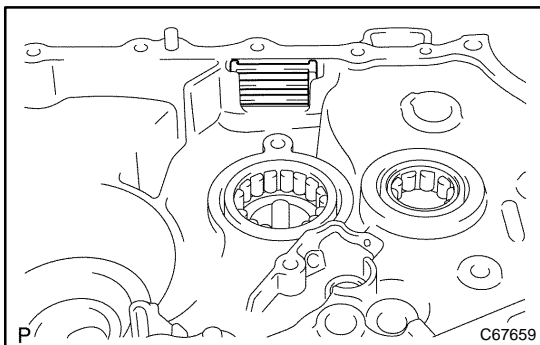
**66. INSTALL TRANSMISSION MAGNET**

- (a) Clean the transmission magnet, install it to the transaxle case.

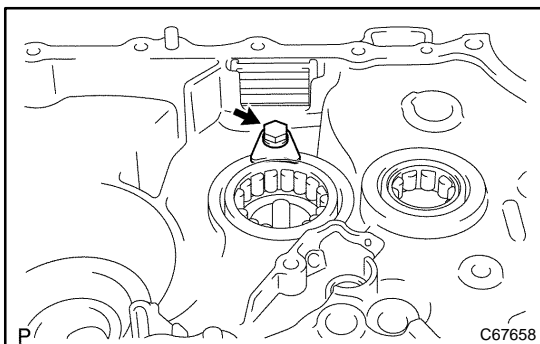
**67. INSTALL BEARING LOCK PLATE**

- (a) Install the bearing lock plate with the bolt.
Torque: 11.3 N·m (115 kgf·cm, 8 ft·lbf)

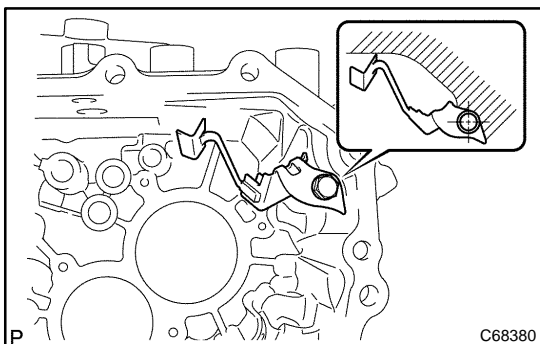
**68. INSTALL OIL RECEIVER PIPE NO.1 (MTM)**

- (a) Install the oil receiver pipe No.1 (MTM) with bolt to the manual transmission case.
Torque: 17.2 N·m (175 kgf·cm, 13 ft·lbf)

NOTICE:

- Prevent the oil receiver pipe No.1 (MTM) from being deformed.
- Install the oil receiver pipe No.1 (MTM) while placing it against the manual transmission case, as shown in the illustration.

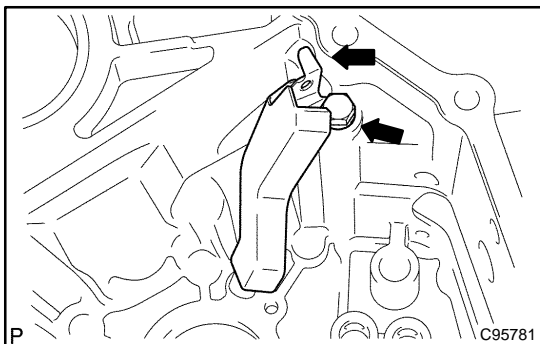
**69. INSTALL OIL RECEIVER PIPE NO.2 (MTM)**

- (a) Install the oil receiver pipe No.2 (MTM) with bolt to the manual transmission case.
Torque: 17.2 N·m (175 kgf·cm, 13 ft·lbf)

NOTICE:

- Prevent the oil receiver pipe No.2 (MTM) from being deformed.
- Install the oil receiver pipe No.2 (MTM) while placing it against the manual transmission case, as shown in the illustration.

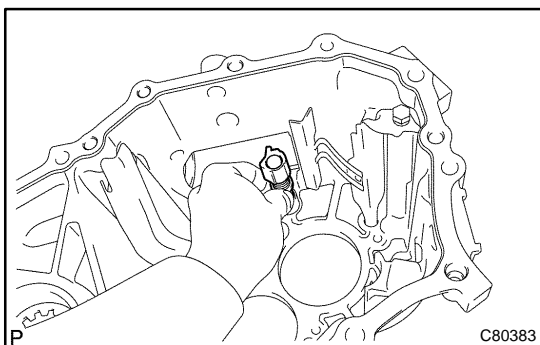
**70. INSTALL REVERSE RESTRICT PIN ASSY**

- (a) Install the reverse restrict pin assy to the manual transmission case.

NOTICE:

Do not set the reverse restrict pin assy in incorrect orientation.

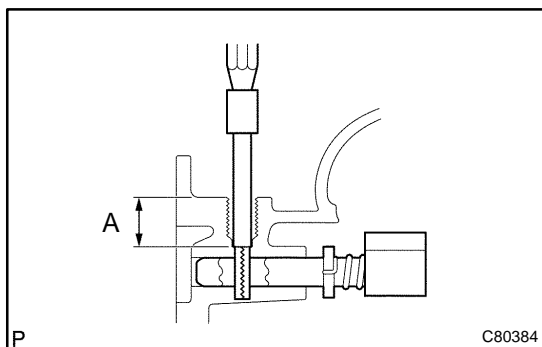

- (b) Using a pin punch (ϕ 5 mm) and hammer, install the slotted pin to the reverse restrict pin assy.

Drive in depth (A):

15.5 – 16.5 mm (0.6102 – 0.6496 in.)

- (c) Apply sealant to the reverse restrict pin plug.

Sealant:

Part No. 08833-00080, THREE BOND 1344, LOCTITE 242 or equivalent

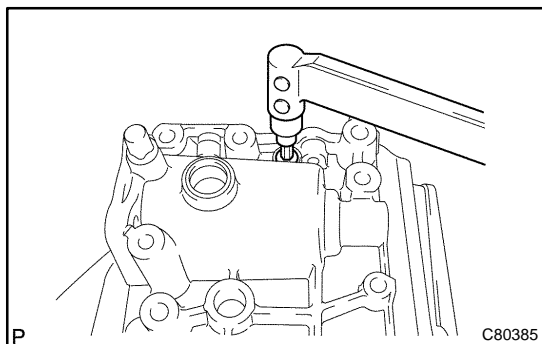

- (d) Using a hexagon wrench and a torque wrench, install the reverse restrict pin plug to the manual transmission case.

Torque: 12.7 N·m (130 kgf·cm, 9 ft·lbf)

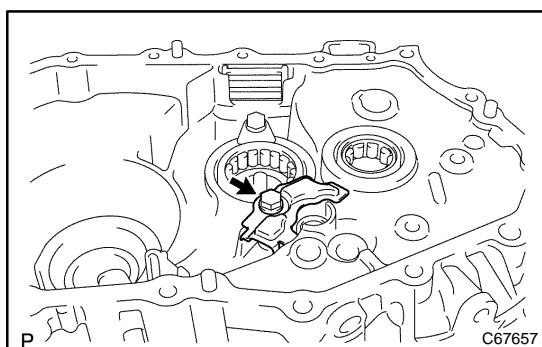

71. INSTALL MANUAL TRANSAXLE CASE RECEIVER

- (a) Install the manual transaxle case receiver with the bolt to the transaxle case.

Torque: 11.3 N·m (115 kgf·cm, 8 ft·lbf)

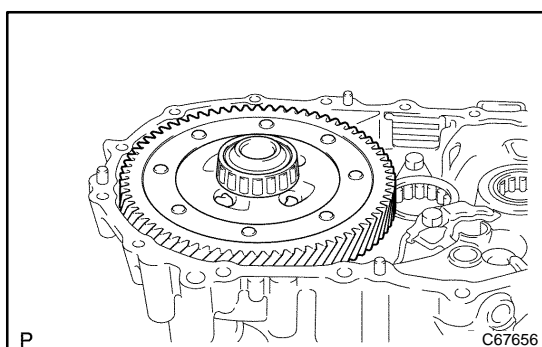

72. INSTALL DIFFERENTIAL CASE ASSY

- (a) Coat the differential case tapered roller bearing with gear oil, install the differential case assy to the transaxle case.

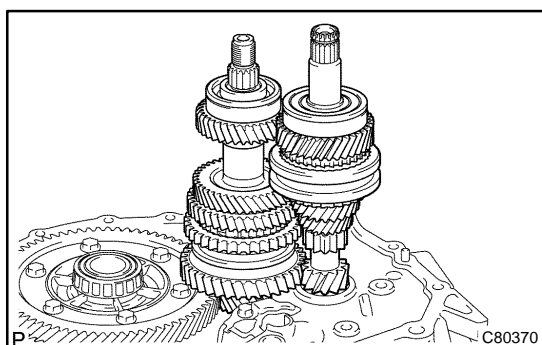

73. INSTALL INPUT SHAFT ASSY

- (a) Coat the sliding and rotating surface of the input and output shafts with gear oil, install them to the transaxle case.

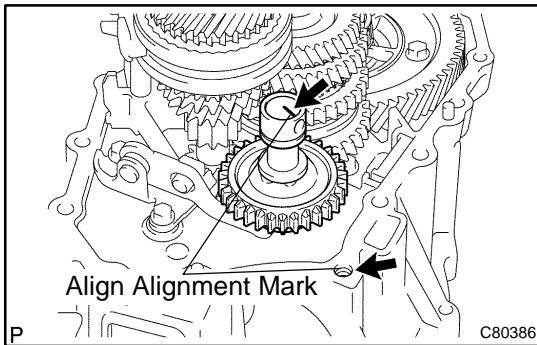
**74. INSTALL REVERSE IDLER GEAR SUB-ASSY**

- (a) Coat the reverse idler gear sub-assy, thrust washer and reverse idler gear shaft with gear oil, install them as shown in the illustration.

HINT:

Align the mark on the reverse idler gear shaft with the bolt hole shown in the illustration.

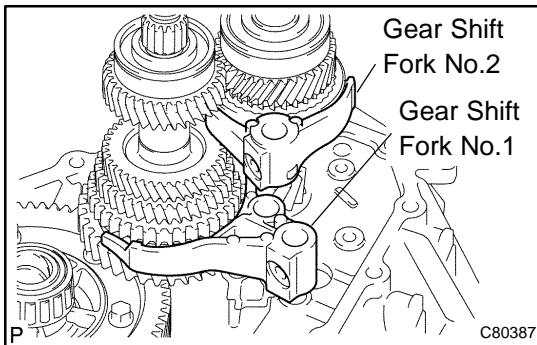
**75. INSTALL GEAR SHIFT FORK SHAFT SUB-ASSY NO.1**

- (a) Coat the gear shift fork No.1 and gear shift fork No.2 with gear oil, install them.

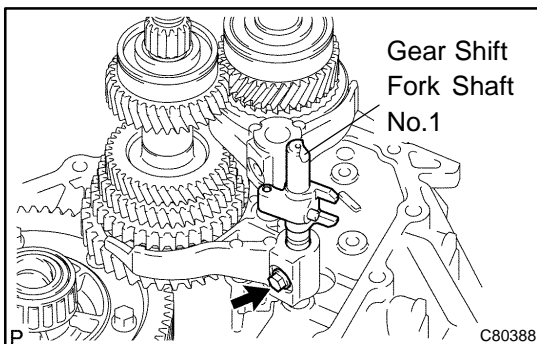

- (b) Coat the gear shift fork shaft sub-assy No.1 with gear oil, install it.

- (c) Apply sealant to the shift fork lock bolt.

Sealant:

Part No. 08833-00080, THREE BOND 1344, LOCTITE 242 or equivalent

- (d) Install the gear shift fork lock bolt.

Torque: 15.7 N·m (160 kgf·cm, 12 ft·lbf)

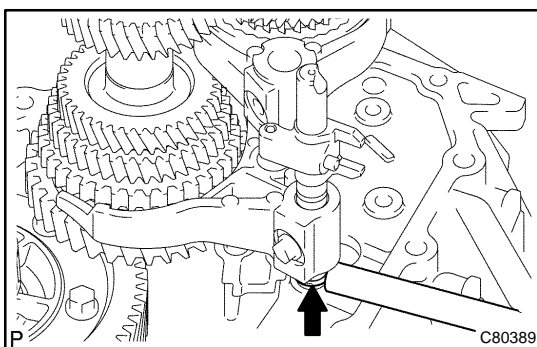

- (e) Using a brass bar and a hammer, install the shaft snap ring to the gear shift fork shaft No.1.

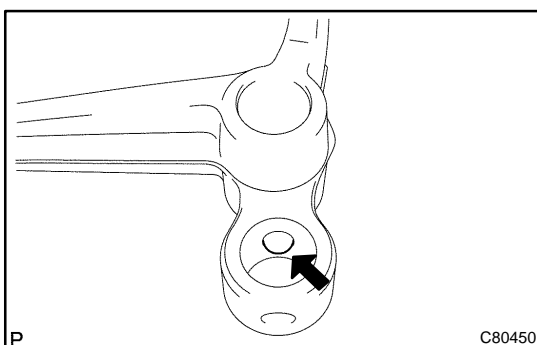
**76. INSTALL GEAR SHIFT FORK SHAFT NO.3**

- (a) Coat the 2 balls with MP grease, install them to the reverse shift fork.

- (b) Install the reverse shift fork to the gear shift fork shaft No.3.

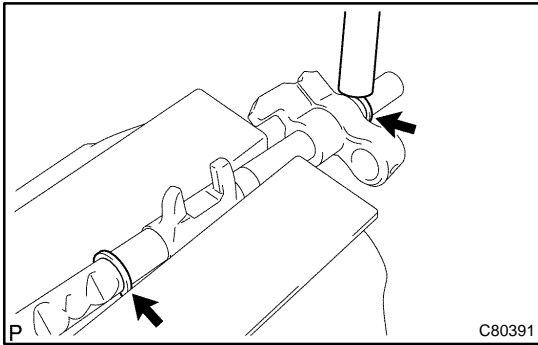

- (c) Using a brass bar and a hammer, install the 2 shift fork shaft snap rings to the gear shift fork shaft No.3.

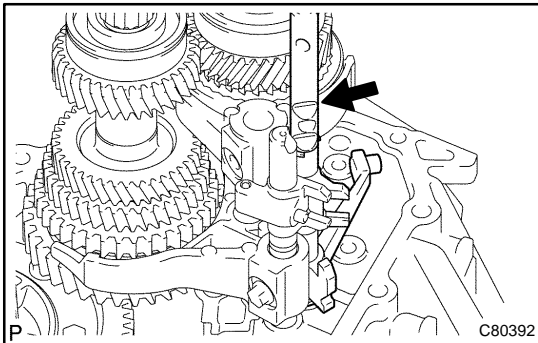

- (d) Coat the gear shift fork shaft No.3 with gear oil, install it.

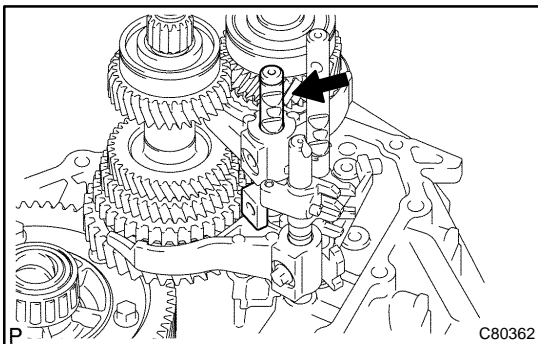

77. INSTALL GEAR SHIFT FORK SHAFT NO.2

- (a) Coat the gear shift head No.1 and gear shift fork shaft No.2 with gear oil, install them.

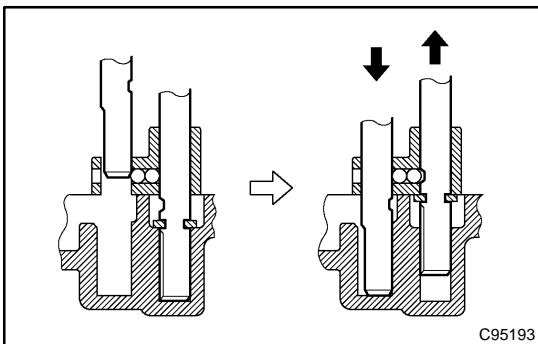

NOTICE:

To avoid the interference of the 2 shift fork balls, lift up the gear shift fork shaft NO.3 at the position shown in the illustration.

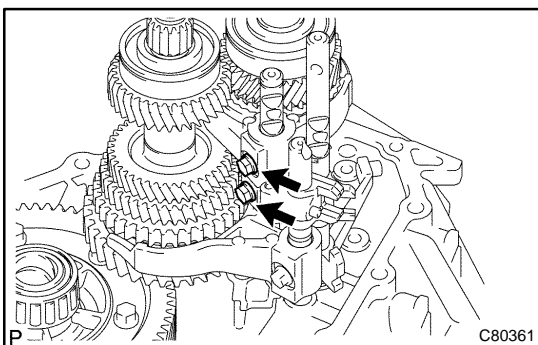

- (b) Coat the 2 shift lock bolts with sealant, install them to the gear shift fork No.2 and gear shift head No.1.

Sealant:

Part No. 08833-00080, THREE BOND 1344, LOCTITE 242 or equivalent

Torque: 15.7 N·m (160 kgf·cm, 12 ft·lbf)

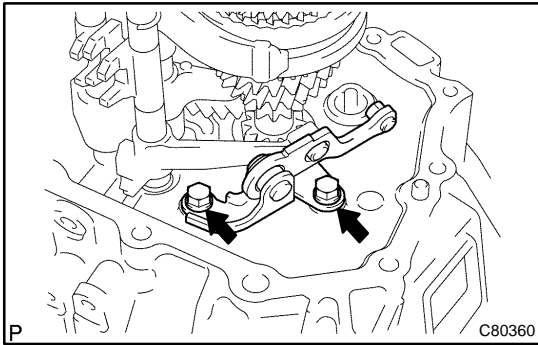

- 78. INSTALL REVERSE SHIFT ARM BRACKET ASSY**
 (a) Install the reverse shift arm bracket assy with 2 bolts to the transaxle case.
Torque: 17.2 N·m (175 kgf·cm, 13 ft·lbf)

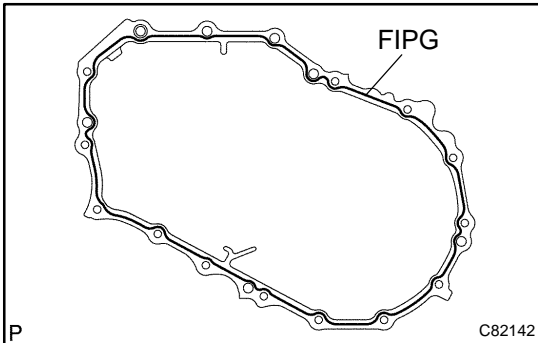

- 79. INSTALL MANUAL TRANSMISSION CASE**
 (a) Apply FIPG to the manual transmission case, as shown in the illustration.
FIPG:
Part No. 08826-00090, THREE BOND 1281 or equivalent

NOTICE:

Parts must be assembled within 10 minutes of application. Otherwise, the packing (FIPG) material must be removed and reapplied.

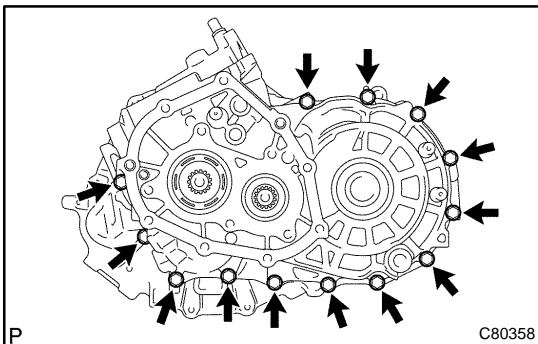

- (b) Coat the 13 bolts with sealant, install them to the manual transmission case.
Sealant:
Part No. 08833-00080, THREE BOND 1344, LOCTITE 242 or equivalent
Torque: 29.4 N·m (300 kgf·cm, 22 ft·lbf)

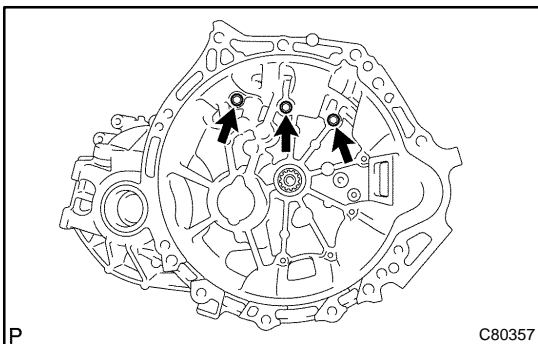

- (c) Coat the 3 bolts with sealant, install them to the transaxle case.
Sealant:
Part No. 08833-00080, THREE BOND 1344, LOCTITE 242 or equivalent
Torque: 29.4 N·m (300 kgf·cm, 22 ft·lbf)

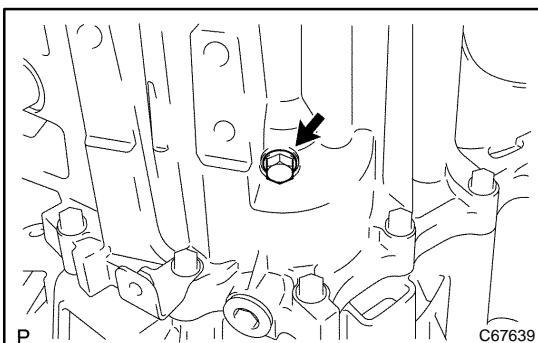

- 80. INSTALL REVERSE IDLER GEAR SHAFT BOLT**
 (a) Coat the reverse idler gear shaft bolt with sealant, install it with a new gasket.
Sealant:
Part No. 08833-00080, THREE BOND 1344, LOCTITE 242 or equivalent
Torque: 29.4 N·m (300 kgf·cm, 22 ft·lbf)

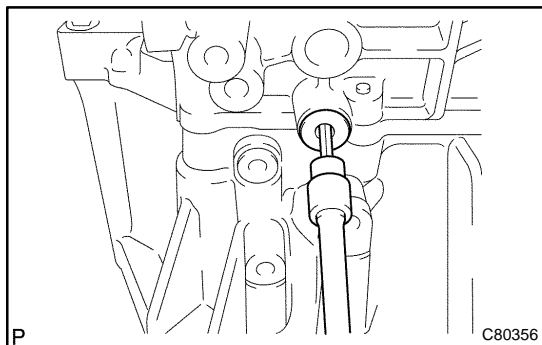
**81. INSTALL LOCK BALL ASSY NO.1**

- (a) Coat the lock ball assy No.1 with sealant, install it with using a hexagon wrench.

Sealant:

Part No. 08833-00080, THREE BOND 1344, LOCTITE 242 or equivalent

Torque: 39.2 N·m (400 kgf·cm, 29 ft·lbf)

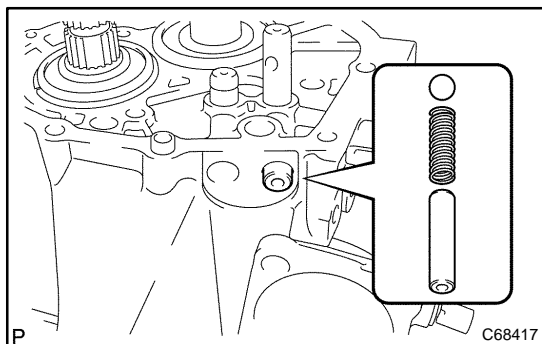
**82. INSTALL SHIFT DETENT BALL**

- (a) Install the 2 shift detent balls, 2 springs with 2 seats to the manual transmission case.

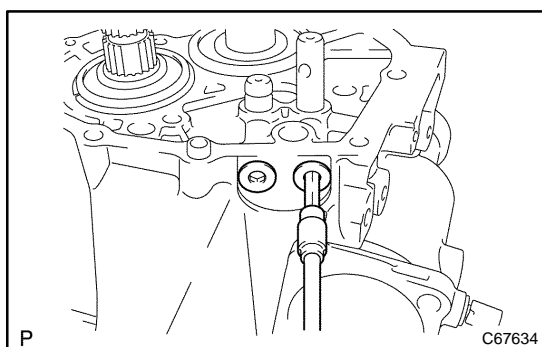

- (b) Coat the 2 shift detent ball plugs with sealant, install them with using a hexagon wrench.

Sealant:

Part No. 08833-00080, THREE BOND 1344, LOCTITE 242 or equivalent

Torque: 24.5 N·m (250 kgf·cm, 18 ft·lbf)

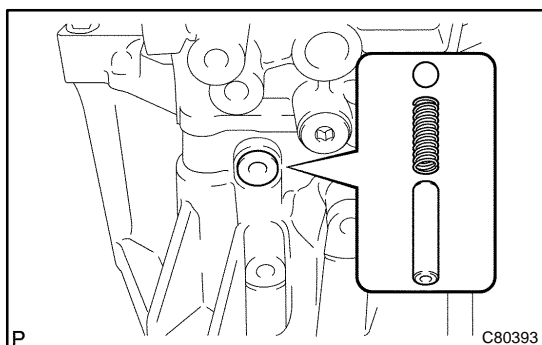

- (c) Install the shift detent ball, spring and seat to the transaxle case.

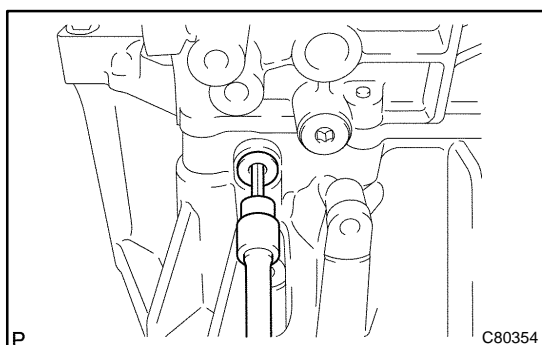

- (d) Coat the shift detent ball plug with sealant, install it with using a hexagon wrench.

Sealant:

Part No. 08833-00080, THREE BOND 1344, LOCTITE 242 or equivalent

Torque: 24.5 N·m (250 kgf·cm, 18 ft·lbf)

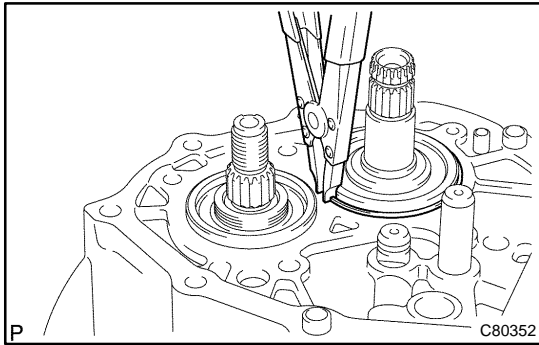

83. INSTALL INPUT SHAFT REAR BEARING HOLE SNAP RING

- (a) Using a snap ring expander, install the input shaft rear bearing hole snap ring to the input shaft.

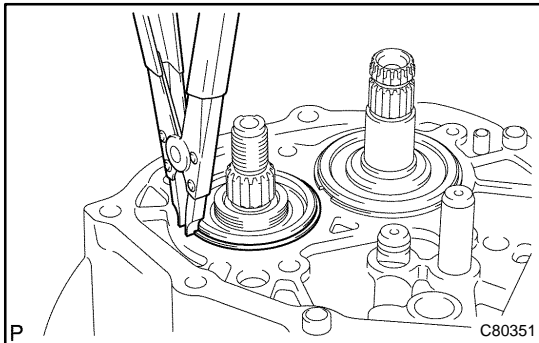

84. INSTALL OUTPUT SHAFT REAR BEARING HOLE SNAP RING

- (a) Using a snap ring expander, install the output shaft rear bearing hole snap ring to the output shaft.

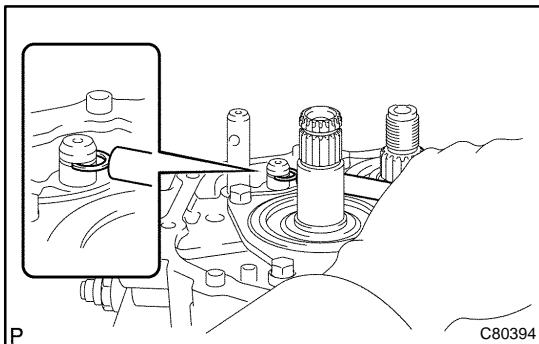

85. INSTALL SHIFT FORK SHAFT SHAFT SNAP RING

- (a) Using a brass bar and a hammer, install the shift fork shaft shaft snap ring to the shift fork shaft No.2.

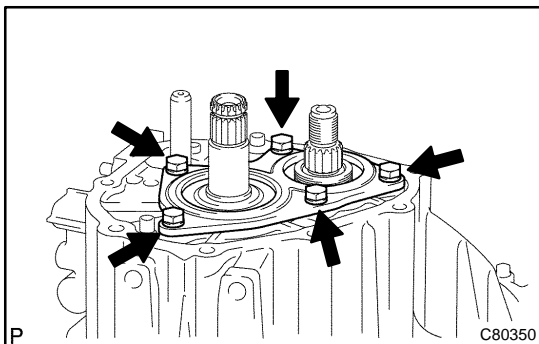

86. INSTALL BEARING RETAINER REAR (MTM)

- (a) Coat the 5 bolts with sealant, install them and bearing retainer rear (MTM) to the manual transmission case.
Torque: 27.4 N·m (279 kgf·cm, 20 ft·lbf)

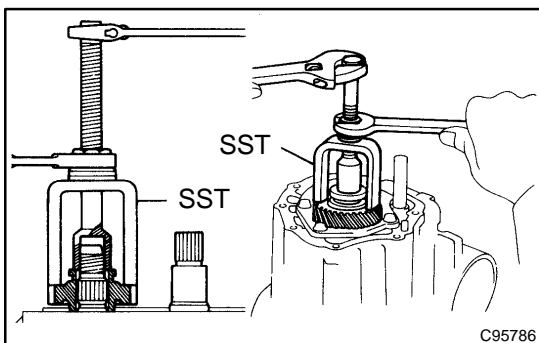

87. INSTALL 5TH DRIVEN GEAR

- (a) Using SST, install the 5th driven gear to the output shaft.
 SST 09309-12020

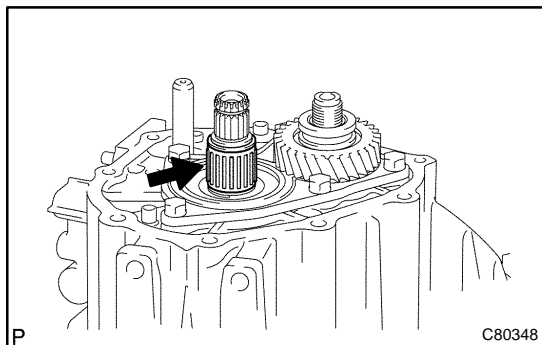
**88. INSTALL 5TH GEAR NEEDLE ROLLER BEARING**

- (a) Coat the 5th gear needle roller bearing and 5th gear bearing spacer with gear oil, install them to the input shaft.

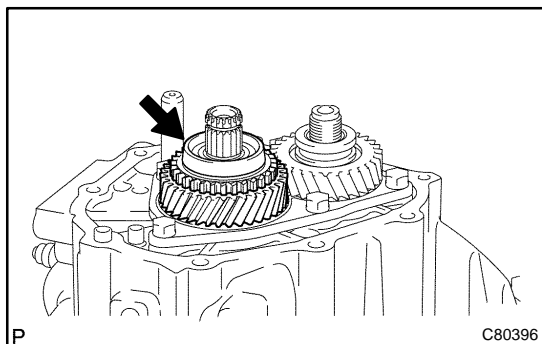
**89. INSTALL 5TH GEAR**

- (a) Coat the 5th gear with gear oil, install it to the input shaft.

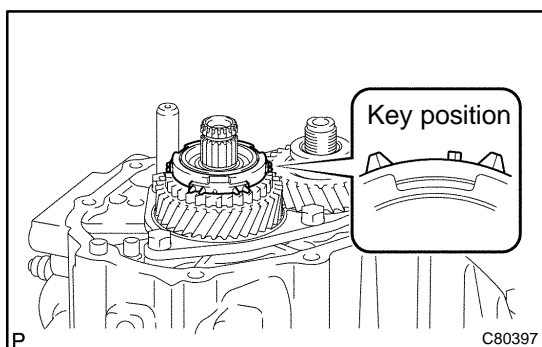
**90. INSTALL SYNCHRONIZER RING NO.3**

- (a) Coat the synchronizer ring No.3 with gear oil, install it to the 5th gear.

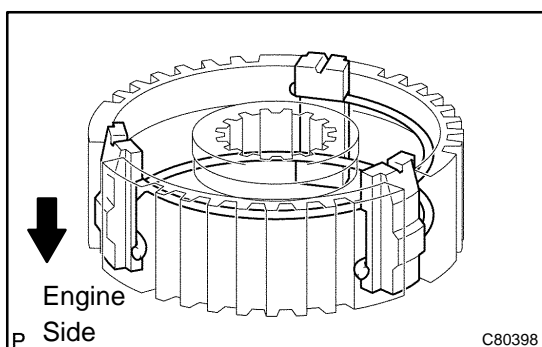
**91. INSTALL TRANSMISSION CLUTCH HUB NO.3**

- (a) Install the 3 synchromesh shifting keys and 2 synchromesh shifting key springs to the transmission clutch hub No.3.

HINT:

Do not set both openings of the shifting key springs in the same position.

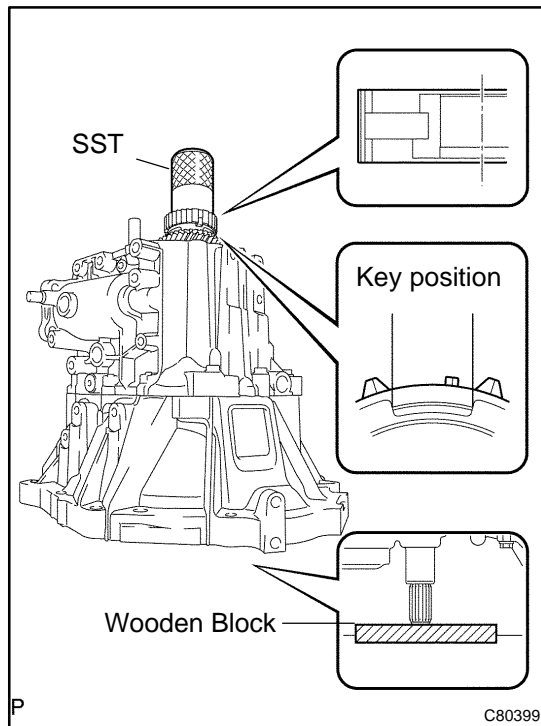

- (b) Using SST and a hammer, install the transmission clutch hub No.3 to the input shaft.

SST 09636-20010

HINT:

- Before driving in the No.3 clutch hub assy, place the suitable sized wooden block on the rear side of the input shaft, as shown in the illustration.
- When driving it in, fix the input shaft firmly so that it is not pushed downward. Otherwise the input shaft rear bearing is over loaded, it might be damaged.

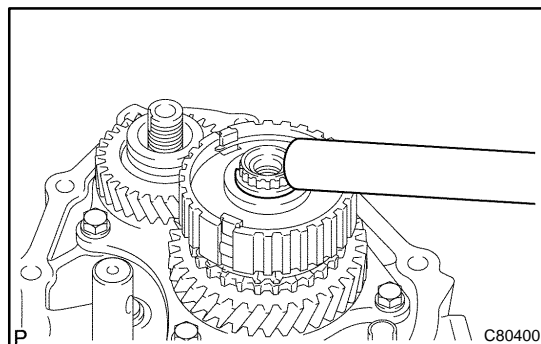

- (c) Select a snap ring from the table below that will make the thrust clearance of the transmission clutch hub No.3 below 0.1 mm (0.0039 in.).

Snap ring thickness:

Mark	Thickness: mm (in.)	Mark	Thickness: mm (in.)
A	2.25 (0.0886)	E	2.49 (0.0980)
B	2.31 (0.0909)	F	2.55 (0.1004)
C	2.37 (0.0933)	G	2.61 (0.1028)
D	2.43 (0.0957)	-	-

- (d) Using a brass bar and a hammer, install the snap ring to the input shaft.

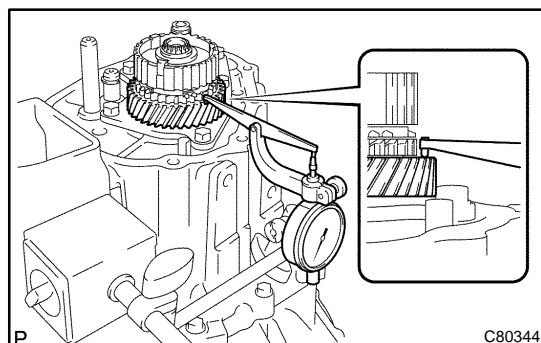

92. INSPECT 5TH GEAR THRUST CLEARANCE

- (a) Using a dial indicator, measure the 5th gear thrust clearance.

5th gear thrust clearance:

Standard clearance: mm (in.)	Maximum clearance: mm (in.)
0.10 – 0.57 (0.0039 – 0.0224)	0.57 (0.0224)

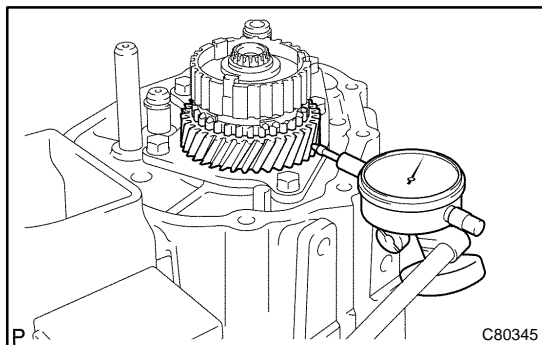

93. INSPECT 5TH GEAR RADIAL CLEARANCE

- (a) Using a dial indicator, measure the 5th gear radial clearance.

5th gear radial clearance:

Standard clearance: mm (in.)	Maximum clearance: mm (in.)
KOYO made: 0.015 - 0.058 (0.0006 - 0.0023)	KOYO made: 0.058 (0.0023)
NSK made: 0.015 - 0.056 (0.0006 - 0.0022)	NSK made: 0.056 (0.0022)

If the clearance exceed the maximum value, replace the gear, needle roller bearing or shaft.

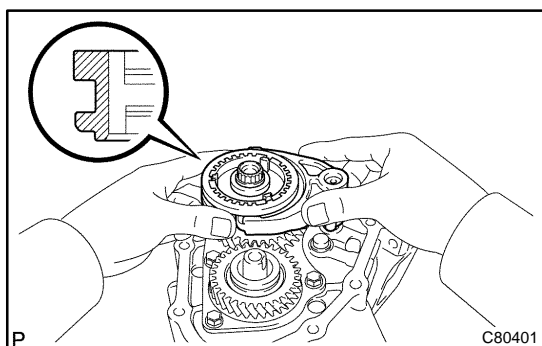

94. INSTALL GEAR SHIFT FORK NO.3

- (a) Coat the transmission clutch hub sleeve No.3 with gear oil, install it and gear shift fork No.3 to the transmission clutch hub No.3.

HINT:

Do not set the transmission clutch hub No.3 in incorrect orientation.

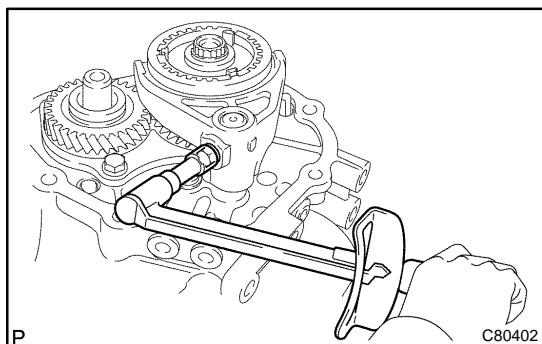

- (b) Coat the gear shift lock fork ball with sealant, install it to the gear shift fork No.3.

Sealant:

Part No. 08833-00080, THREE BOND 1344, LOCTITE 242 or equivalent

Torque: 15.7 N·m (160 kgf·cm, 12 ft·lbf)

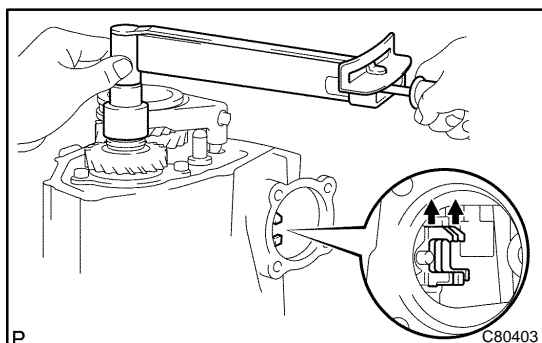

95. INSTALL MANUAL TRANSMISSION OUTPUT SHAFT REAR SET NUT

- (a) Engage the gear double meshing.
(b) Install a new manual transmission output shaft rear set nut.

Torque: 117.6 N·m (1,200 kgf·cm, 87 ft·lbf)

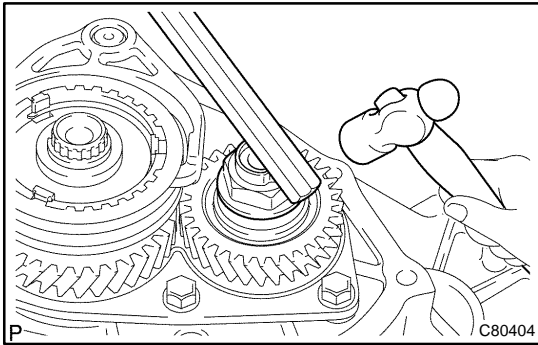

- (c) Using a chisel and a hammer, stake the manual transmission output shaft rear set nut.
- (d) Disengage the gear double meshing.

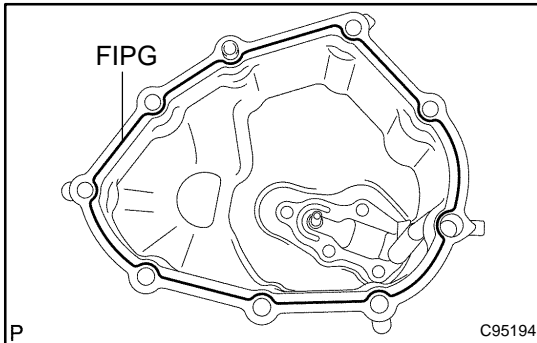

96. INSTALL MANUAL TRANSMISSION CASE COVER SUB-ASSY

- (a) Apply FIPG to the manual transmission case cover sub-assy as shown in the illustration.

FIPG:

Part No. 08826-00090, THREE BOND 1281 or equivalent

NOTICE:

Parts must be assembled within 10 minutes of application. Otherwise, the packing (FIPG) material must be removed and reapplied.

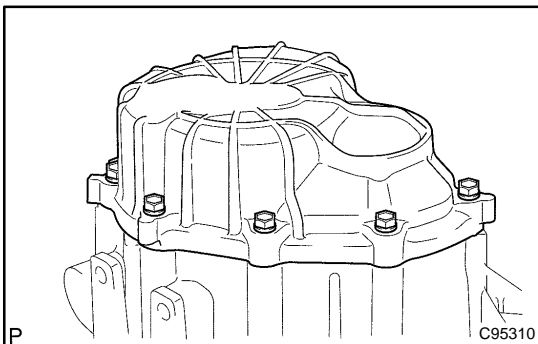

- (b) Install the manual transmission case cover sub-assy with the 9 bolts to the manual transmission case.

Torque: 18.1 N·m (185 kgf·cm, 14 ft·lbf)

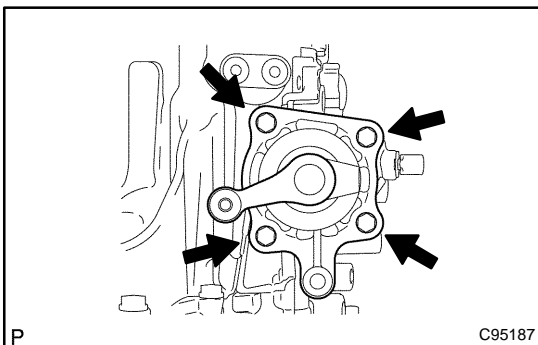

97. INSTALL SHIFT & SELECT LEVER SHAFT ASSY

- (a) Coat the 4 bolts with sealant, install them, new gasket and shift & select lever shaft assy to the manual transmission case.

Sealant:

Part No. 08833-00080, THREE BOND 1344, LOCTITE 242 or equivalent

Torque: 19.6 N·m (200 kgf·cm, 14 ft·lbf)

NOTICE:

Set the claws of the shift interlock plate into the shift head part of the gear shift fork shaft securely.

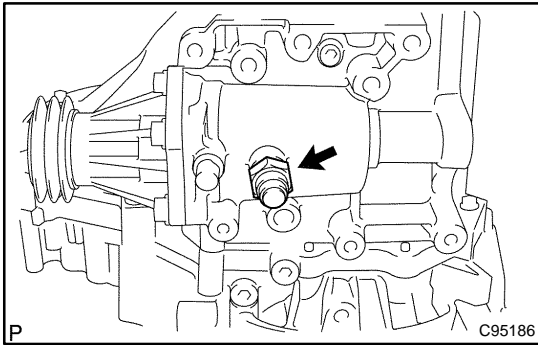
**98. INSTALL LOCK BALL ASSY NO.1**

- (a) Coat the lock ball assy No.1 with sealant, install it to the manual transmission case.

Sealant:

Part No. 08833-00080, THREE BOND 1344, LOCTITE 242 or equivalent

Torque: 29.4 N·m (300 kgf·cm, 22 ft·lbf)

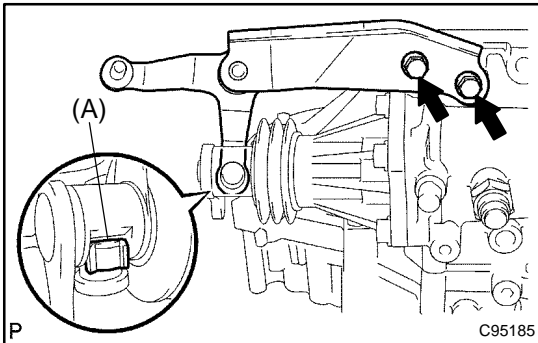
**99. INSTALL SELECTING BELL CRANK ASSY**

- (a) Install the selecting bellcrank assy with control shift lever bush with the 2 bolts to the manual transmission case.

Torque: 24.5 N·m (250 kgf·cm, 18 ft·lbf)

NOTICE:

Apply MP grease to the inside circumferential surface of the control shift lever bush (A).

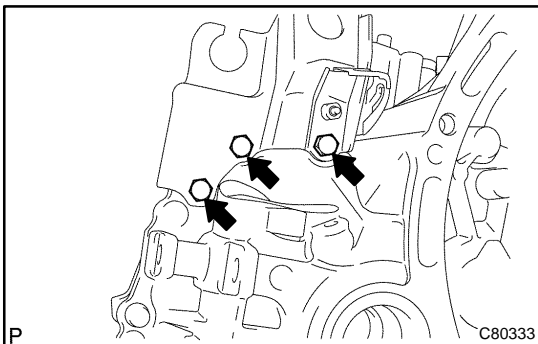
**100. INSTALL FLOOR SHIFT CONTROL LEVER HOUSING SUPPORT BRACKET**

- (a) Install the floor shift control lever housing support bracket with the 3 bolts to the transaxle case.

Torque: 11.3 N·m (115 kgf·cm, 8 ft·lbf)

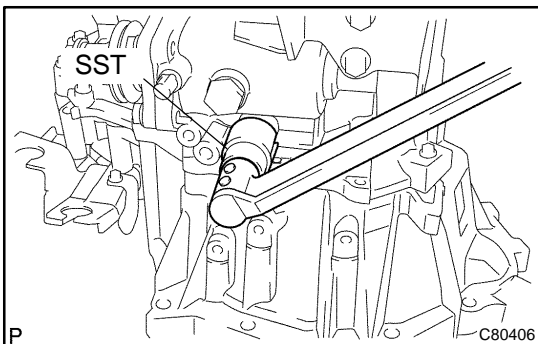
**101. INSTALL BACK UP LAMP SWITCH ASSY**

- (a) Using SST, install the backup lamp switch assy with a new gasket to the manual transmission case.

Torque: 40.2 N·m (410 kgf·cm, 30 ft·lbf)

SST 09817-16011

102. INSTALL SPEEDOMETER DRIVEN HOLE COVER SUB-ASSY (W/ ABS)

- (a) Install a new O-ring to the speedometer driver hole cover sub-assy.
 (b) Install the speedometer driver hole cover sub-assy with the bolt.

Torque: 11.3 N·m (115 kgf·cm, 8 ft·lbf)

103. INSTALL SPEEDOMETER DRIVEN (MTM) GEAR SUB-ASSY (W/O ABS)

- (a) Install the speedometer driven (MTM) gear sub-assy with clip to the speedometer sensor.

104. INSTALL SPEEDOMETER SENSOR (W/O ABS)

- (a) Install a new O-ring to the speedometer sensor.
 (b) Install the speedometer sensor with the bolt.

Torque: 11.3 N·m (115 kgf·cm, 8 ft·lbf)

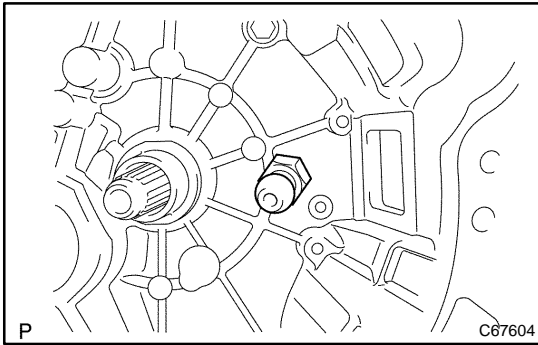
**105. INSTALL RELEASE FORK SUPPORT**

- (a) Install the release fork support to the transaxle case.
Torque: 36.8 N·m (375 kgf·cm, 25 ft·lbf)

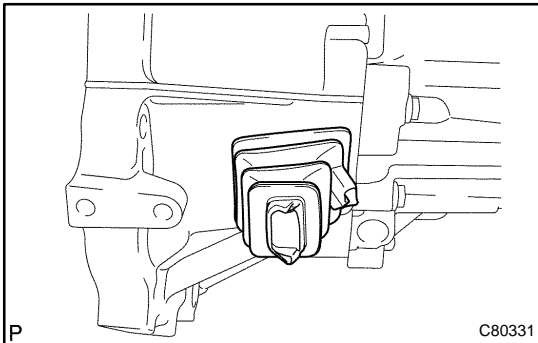
**106. INSTALL CLUTCH RELEASE FORK BOOT**

- (a) Install the clutch release fork boot to the transaxle case.

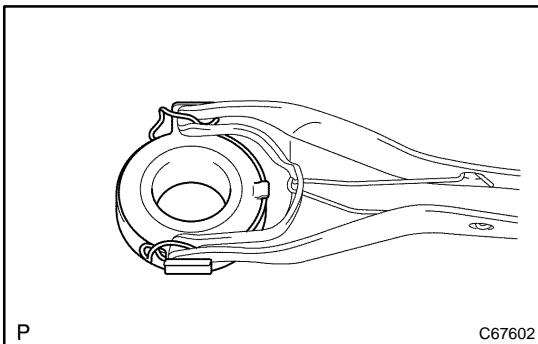
**107. INSTALL CLUTCH RELEASE BEARING ASSY**

- (a) Coat the clutch release bearing assy with the release hub grease, install it to the clutch release fork sub-assy.

Sealant:

Part No. 08887-01806, RELEASE HUB GREASE or equivalent

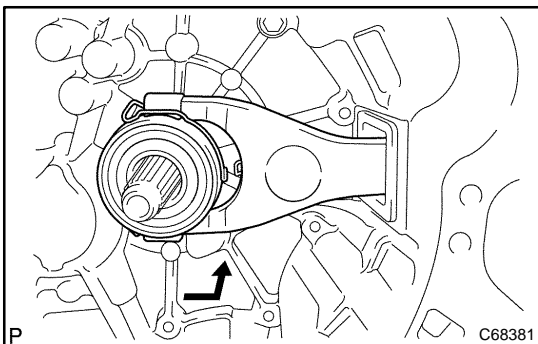
**108. INSTALL CLUTCH RELEASE FORK SUB-ASSY**

- (a) Install the clutch release fork sub-assy to the input shaft.
 (b) Apply clutch spline grease to spline of the input shaft.

Sealant:

Part No. 08887-01806, CLUTCH SPLINE GREASE or equivalent

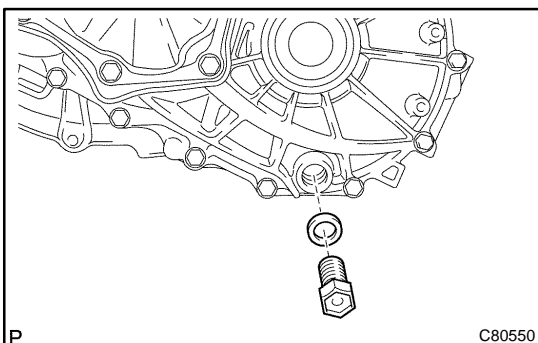
**109. INSTALL DRAIN (MTM) PLUG SUB-ASSY**

- (a) Install a new gasket with the drain (MTM) plug sub-assy.
Torque: 39.2 N·m (400 kgf·cm, 29 ft·lbf)

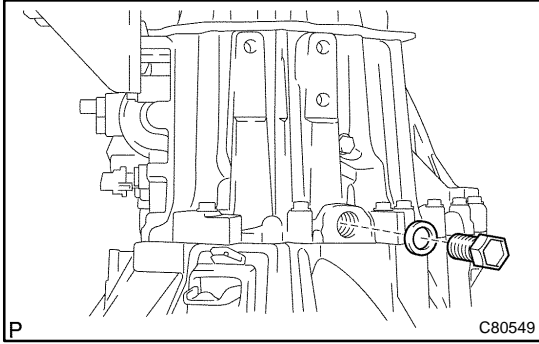
**110. INSTALL MANUAL TRANSMISSION FILLER PLUG**

- (a) Install a new gasket with the manual transmission filler plug.

Torque: 39.2 N·m (400 kgf·cm, 29 ft·lbf)

OVERHAUL

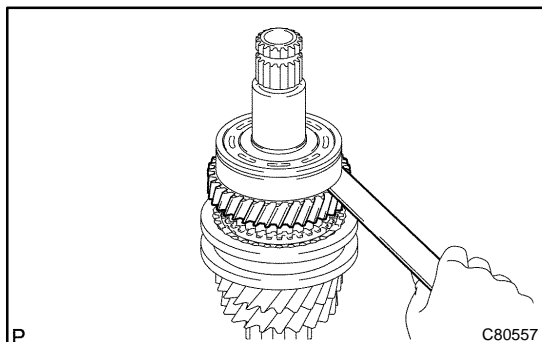
**1. INSPECT 4TH GEAR THRUST CLEARANCE**

- (a) Using a feeler gauge, measure the 4th gear thrust clearance.

4th gear thrust clearance:

Standard clearance: mm (in.)	Maximum clearance: mm (in.)
0.10 - 0.55 (0.0039 - 0.0217)	0.55 (0.0217)

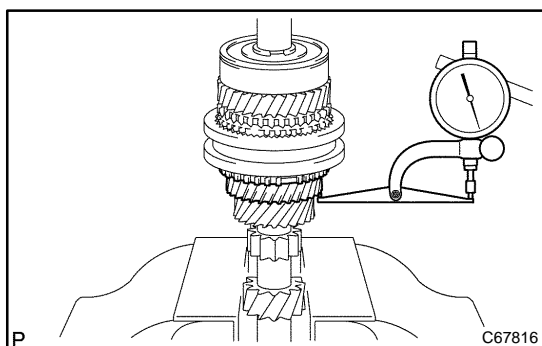
**2. INSPECT 3RD GEAR THRUST CLEARANCE**

- (a) Using a dial indicator, measure the 3rd gear thrust clearance.

3rd gear thrust clearance:

Standard clearance: mm (in.)	Maximum clearance: mm (in.)
0.10 - 0.35 (0.0039 - 0.0138)	0.35 (0.0138)

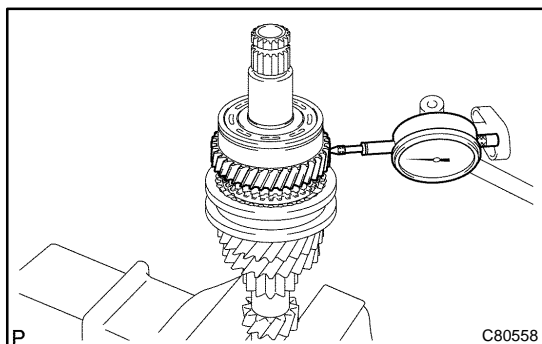
**3. INSPECT 4TH GEAR RADIAL CLEARANCE**

- (a) Using a dial indicator, measure the 4th gear radial clearance.

4th gear radial clearance:

	Standard clearance: mm (in.)	Maximum clearance: mm (in.)
KOYO made	0.015 - 0.058 (0.0006 - 0.0023)	0.058 (0.0023)
NSK made	0.015 - 0.056 (0.0006 - 0.0022)	0.056 (0.0022)

If the clearance exceeds the maximum, replace the gear, needle roller bearing or shaft.

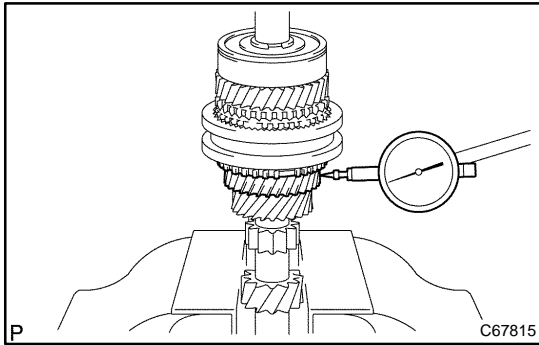

4. INSPECT 3RD GEAR RADIAL CLEARANCE

- (a) Using a dial indicator, measure the 3rd gear radial clearance.

3rd gear radial clearance:

	Standard clearance: mm (in.)	Maximum clearance: mm (in.)
KOYO made	0.015 - 0.058 (0.0006 - 0.0023)	0.058 (0.0023)
NSK made	0.015 - 0.056 (0.0006 - 0.0022)	0.0056 (0.0022)

If the clearance exceeds the maximum, replace the gear, needle roller bearing or shaft.

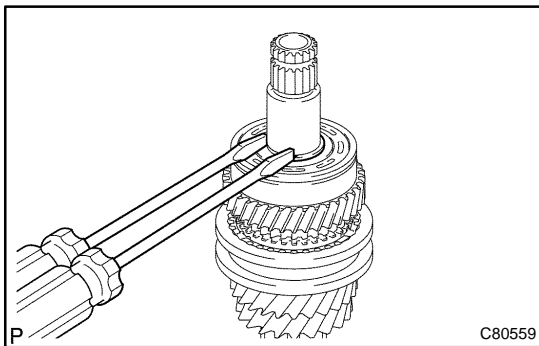

5. REMOVE 4TH GEAR

- (a) Using 2 screwdrivers and a hammer, tap out the snap ring.

HINT:

Using a waste to prevent the snap ring from being scattered.

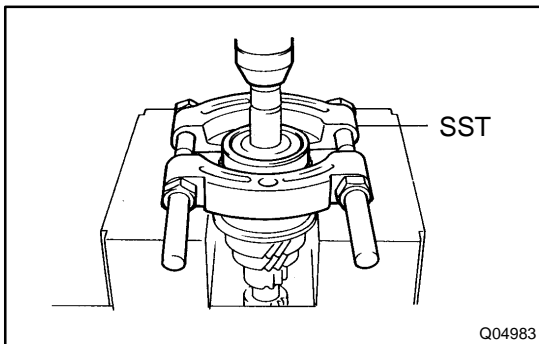

- (b) Using SST and a press, remove the input shaft radial ball bearing rear and 4th gear from the input shaft.

SST 09950-00020

NOTICE:

- Do not tighten SST excessively.
- Support the input shaft assy by hand so that it will not be dropped off.

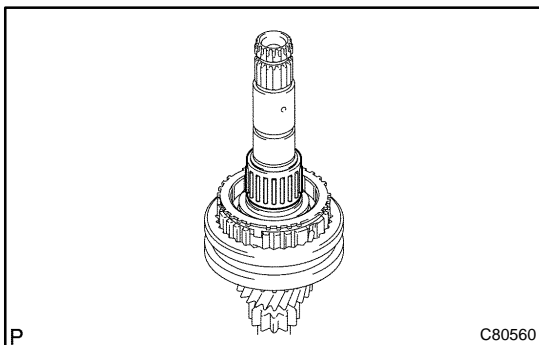

6. REMOVE 4TH GEAR NEEDLE ROLLER BEARING

- (a) Remove the 4th gear needle roller bearing and 4th gear bearing spacer from the input shaft.

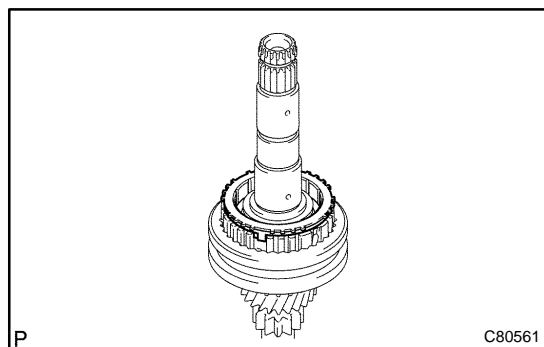
**7. REMOVE 4TH GEAR SYNCHRONIZER RING**

- (a) Remove the 4th gear synchronizer ring from the transmission clutch hub No.2.

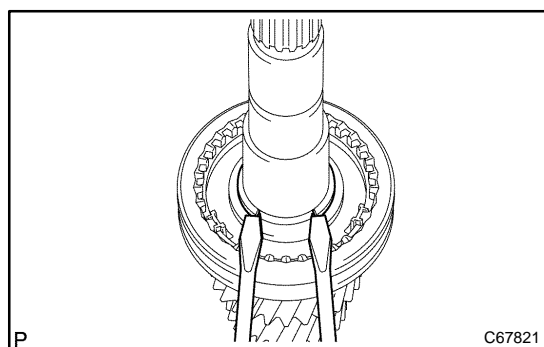
**8. REMOVE 3RD GEAR**

- (a) Using 2 screwdrivers and a hammer, tap out the snap ring.

HINT:

Using a waste to prevent the snap ring from being scattered.

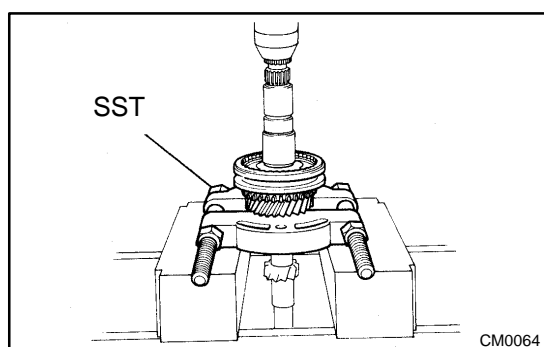

- (b) Using SST and a press, remove the transmission clutch hub No.2 and 3rd gear from the input shaft.

SST 09950-00020

NOTICE:

- Do not tighten SST excessively.
- Support the input shaft by hand so that it will not be dropped off.

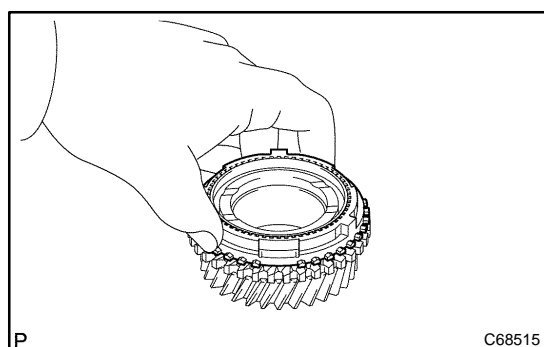
**9. REMOVE 3RD GEAR SYNCHRONIZER RING**

- (a) Remove the 3rd gear synchronizer ring from the 3rd gear.

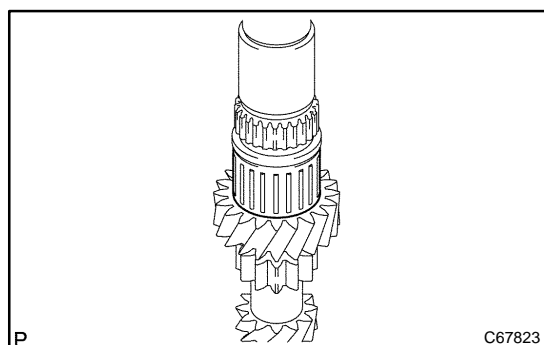
**10. REMOVE 3RD GEAR NEEDLE ROLLER BEARING**

- (a) Remove the 3rd gear needle roller bearing from the input shaft.

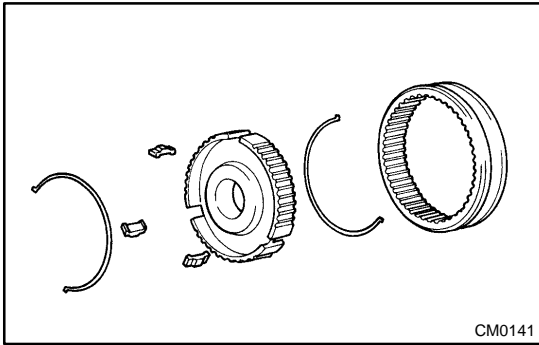

11. REMOVE TRANSMISSION HUB SLEEVE NO.2

- (a) Remove the transmission hub sleeve No.2, 3 synchromesh shifting keys and 2 synchromesh shifting key springs from the transmission clutch hub No.2.

HINT:

Using a waste to prevent the shifting key and shifting key spring from being scattered.

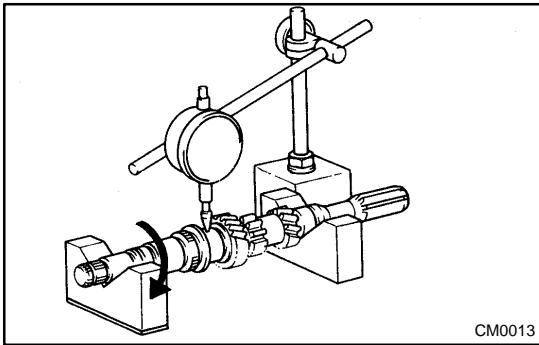

12. INSPECT INPUT SHAFT

- (a) Using a dial indicator, check the shaft runout.

Maximum runout: 0.015 mm(0.0006 in.)

If the runout exceeds the maximum, replace the input shaft.

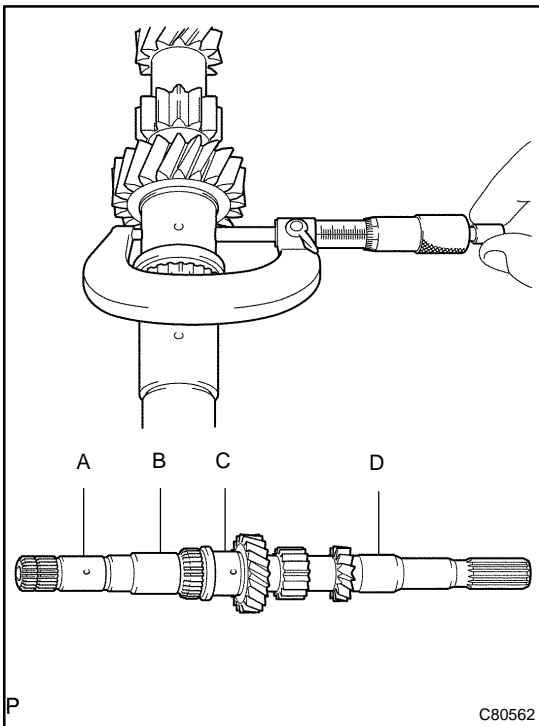

- (b) Using a micrometer, measure the outer diameter of the input shaft journal surface.

Input shaft outer diameter:

Part	Standard outer diameter: mm (in.)	Minimum outer diameter: mm (in.)
A	24.885 - 24.900 (0.9797 - 0.9803)	24.885 (0.9797)
B	28.985 - 29.000 (1.1411 - 1.1417)	28.985 (1.1411)
C	30.985 - 31.000 (1.2198 - 1.2204)	30.985 (1.2198)
D	24.985-25.000 (0.9836 - 0.9842)	24.985 (0.9836)

If the outer diameter is below the minimum, replace the input shaft.

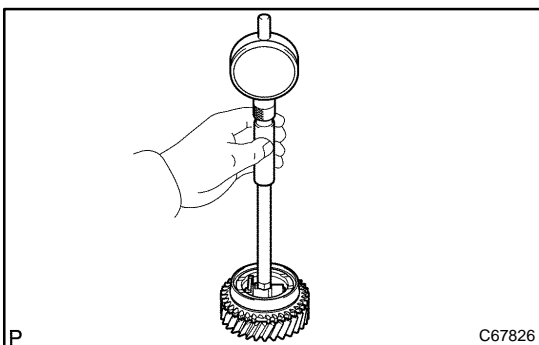

13. INSPECT 4TH GEAR

- (a) Using a cylinder gauge, measure the inside diameter of the 4th gear.

Standard inside diameter:

34.015 - 34.031 mm (1.3391 - 1.3398 in.)

Maximum inside diameter:

34.031 mm (1.3398 in.)

If the inside diameter exceeds the maximum, replace the 4th gear.

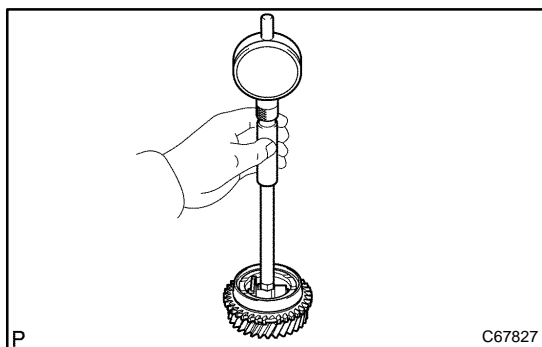
**14. INSPECT 3RD GEAR**

- (a) Using a cylinder gauge, measure the inside diameter of the 3rd gear.

Standard inside diameter:

36.015 – 36.031 mm (1.4179 – 1.4185 in.)

Maximum inside diameter:

36.031 mm (1.4185 in.)

If the inside diameter exceeds the maximum, replace the 3rd gear.

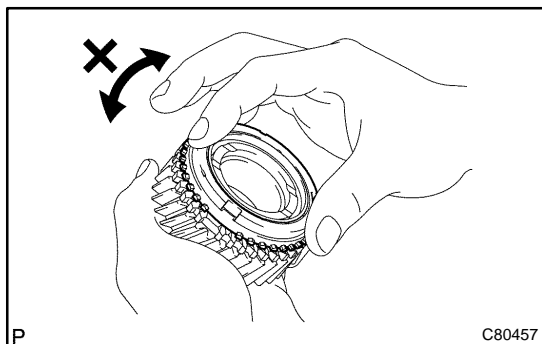
**15. INSPECT 3RD GEAR SYNCHRONIZER RING**

- (a) Check for wear or damage.
 (b) Check the braking effect of the 3rd gear synchronizer ring. Turn the 3rd gear synchronizer ring in one direction while pushing it to the gear cone. Check that the ring locks.

If the braking effect is insufficient, apply a small amount of the fine lapping compound between 3rd gear synchronizer ring and 3rd gear cone. Lightly rub the 3rd gear synchronizer ring and 3rd gear cone together.

NOTICE:

Ensure the fine lapping compound is completely washed off after rubbing.

- (c) Check again the braking effect of the synchronizer ring.

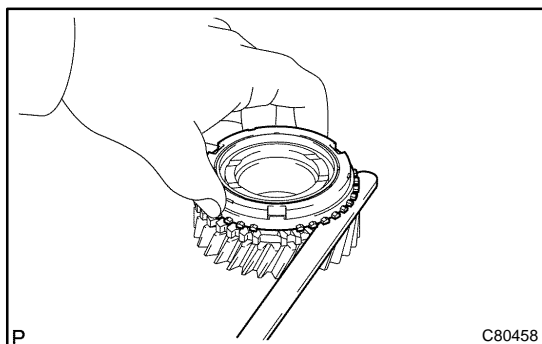

- (d) Using a feeler gauge, measure the clearance between 3rd gear synchronizer ring back and 3rd gear spline end.

Minimum clearance:

0.65 mm (0.0256 in.)

If the clearance below than the minimum, replace the 3rd gear synchronizer ring, and apply small amount of the fine lapping compound on gear cone.

NOTICE:

Ensure the fine lapping compound is completely washed off after rubbing.

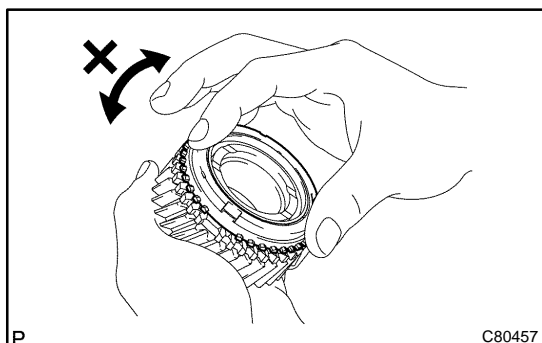
**16. INSPECT 4TH GEAR SYNCHRONIZER RING**

- (a) Check for wear or damage.
 (b) Check the braking effect of the 4th gear synchronizer ring. Turn the 4th gear synchronizer ring in one direction while pushing it to the gear cone. Check that the ring locks.

If the braking effect is insufficient, apply a small amount of the fine lapping compound between 4th gear synchronizer ring and 4th gear cone. Lightly rub the 4th gear synchronizer ring and 4th gear cone.

NOTICE:

Ensure the fine lapping compound is completely washed off after rubbing.

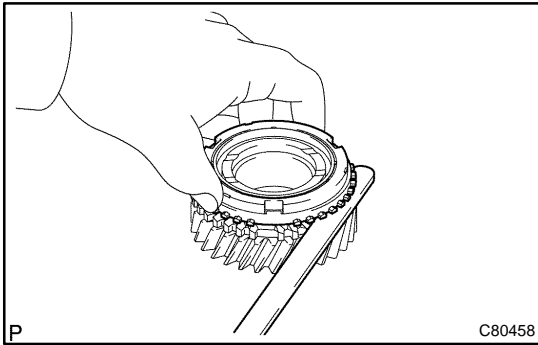

- (c) Using a feeler gauge, measure the clearance between 4th gear synchronizer ring back and 4th gear spline end.
Minimum clearance: 0.75 mm (0.0295 in.)

If the clearance below than the minimum, replace the 4th gear synchronizer ring, and apply small amount of the fine lapping compound on gear cone.

NOTICE:

Ensure the fine lapping compound is completely washed off after rubbing.

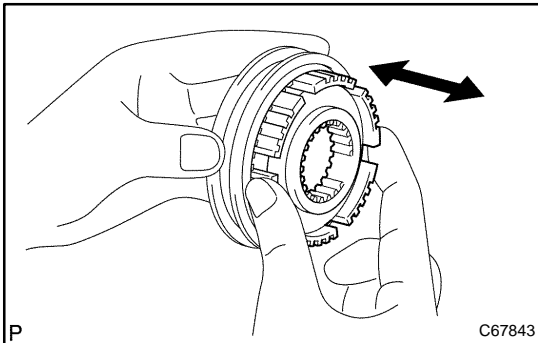

17. INSPECT TRANSMISSION HUB SLEEVE NO.2

- (a) Check the sliding condition between the transmission hub sleeve No.2 and transmission clutch hub No.2.
(b) Check that the spline gear's edges of the transmission hub sleeve No.2 is not worn down.

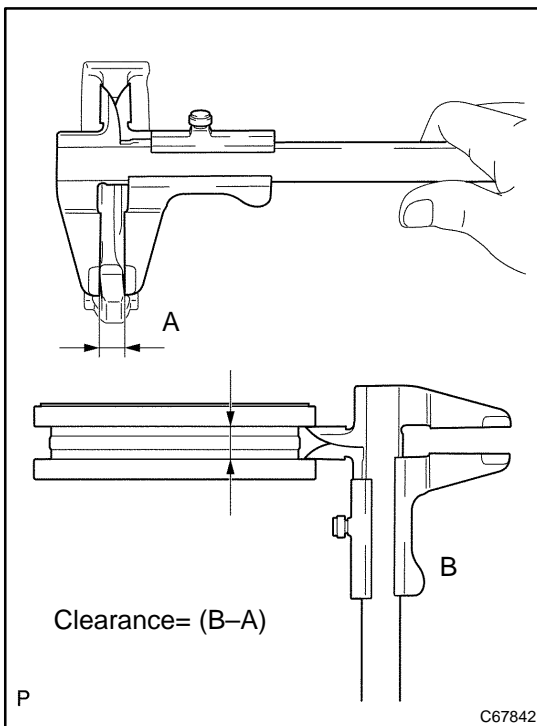

- (c) Using a vernier caliper, inspect the transmission hub sleeve No.2 and gear shift fork No.2 as shown in the illustration.

Standard clearance:

0.15 - 0.35 mm (0.0059 - 0.0137 in.)

If the clearance is out of specification, replace the transmission hub sleeve No.2 and gear shift fork No.2.

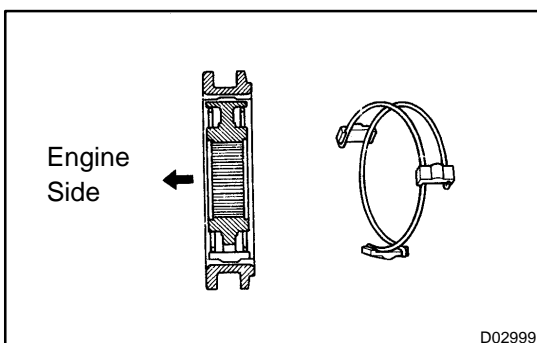

18. INSTALL TRANSMISSION HUB SLEEVE NO.2

- (a) Coat the transmission hub sleeve No.2 with gear oil, install it to the transmission clutch hub No.2.

NOTICE:

Do not set the transmission clutch hub sleeve No.2 and the transmission clutch hub No.2 in incorrect orientation.

- (b) Install the 2 synchromesh key springs with 3 synchromesh shifting keys to the transmission clutch hub No.2.

HINT:

Do not set the both openings of the shifting key springs in the same position.

19. INSTALL 3RD GEAR NEEDLE ROLLER BEARING

- (a) Coat the 3rd gear needle roller bearing with gear oil, install it to the input shaft.

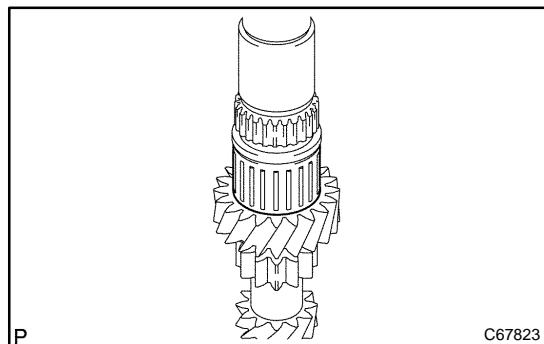

20. INSTALL 3RD GEAR

- (a) Coat the 3rd gear with gear oil, install it to the input shaft.

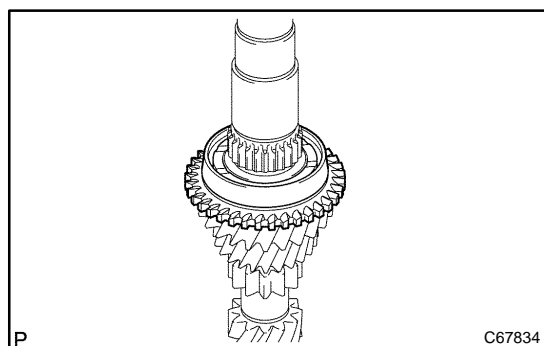

21. INSTALL 3RD GEAR SYNCHRONIZER RING

- (a) Coat the 3rd gear synchronizer ring with gear oil, install it to the 3rd gear.

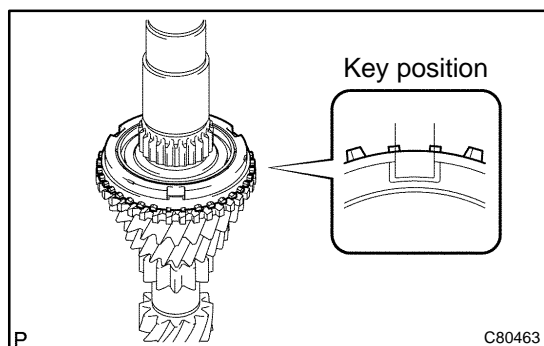

22. INSTALL TRANSMISSION CLUTCH HUB NO.2

- (a) Using SST and a press, install the transmission clutch hub No.2 to the input shaft.

SST 09316-60011 (09316-00021)

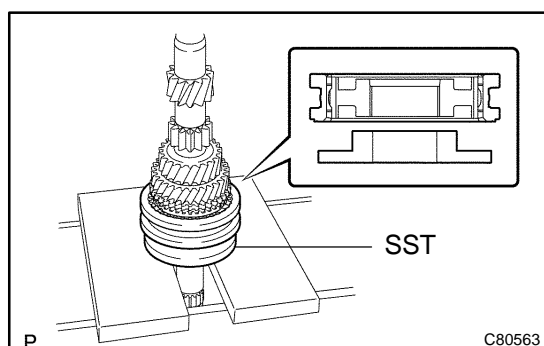

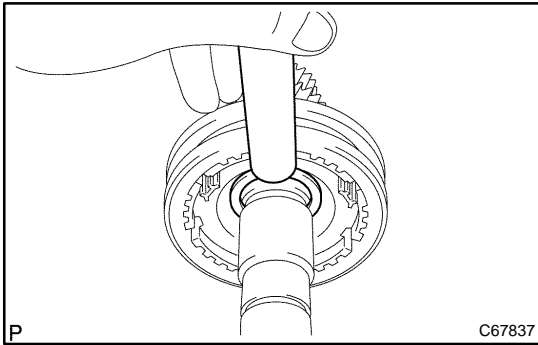

- (b) Select a snap ring from the table below that will make the thrust clearance of the transmission clutch hub No.2 below 0.1 mm (0.0039 in.).

Snap ring thickness:

Mark	Thickness: mm (in.)	Mark	Thickness: mm (in.)
0	2.30 (0.0906)	3	2.48 (0.0976)
1	2.36 (0.0929)	4	2.54 (0.1000)
2	2.42 (0.0953)	5	2.60 (0.1024)

- (c) Using a brass bar and a hammer, tap in the snap ring.

NOTICE:

Take care not to damage the journal surface of the input shaft.

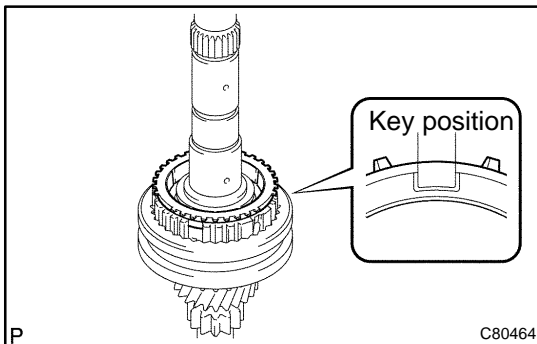

23. INSTALL 4TH GEAR SYNCHRONIZER RING

- (a) Coat the 4th gear synchronizer ring with gear oil, install it to the transmission clutch hub No.2.

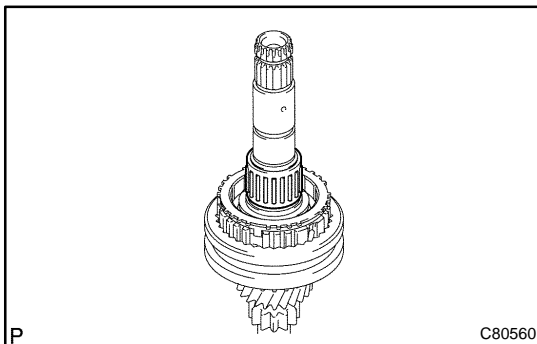

24. INSTALL 4TH GEAR NEEDLE ROLLER BEARING

- (a) Coat the 4th gear needle roller bearing and 4th gear bearing spacer with gear oil, install them to the input shaft.

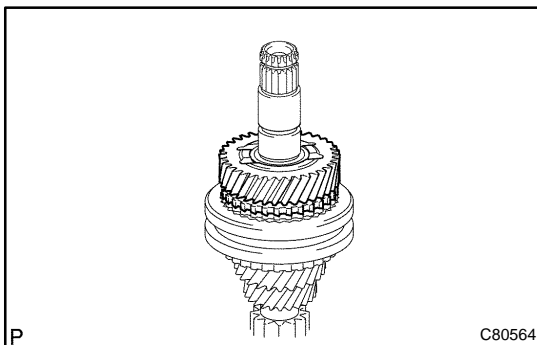

25. INSTALL 4TH GEAR

- (a) Coat the 4th gear with gear oil, install it to the input shaft.

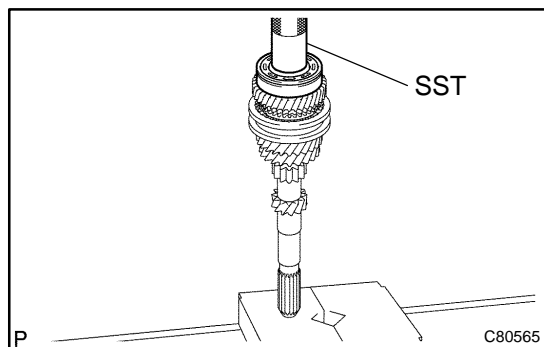

26. INSTALL INPUT SHAFT REAR RADIAL BALL BEARING

- (a) Using SST and a press, install the input shaft rear radial ball bearing to the input shaft.

SST 09636-20010

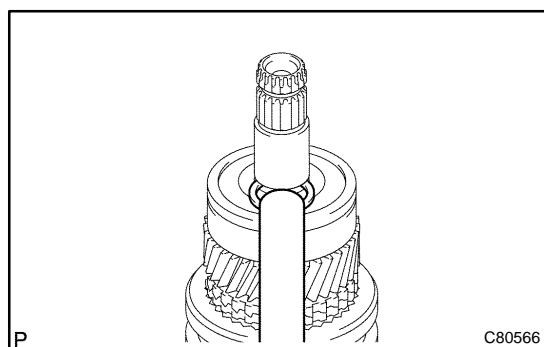

- (b) Select a snap ring from the table below that will make the thrust clearance of the input shaft rear radial ball bearing below 0.1 mm (0.0039 in.).

Snap ring thickness:

Mark	Thickness: mm (in.)	Mark	Thickness: mm (in.)
0	2.29 (0.0901)	3	2.47 (0.0972)
1	2.35 (0.0925)	4	2.53 (0.0996)
2	2.41 (0.0948)	5	2.59 (0.1019)

- (c) Using a brass bar and a hammer, tap in the snap ring.

NOTICE:

Take care not to damage the journal surface of the snap ring.

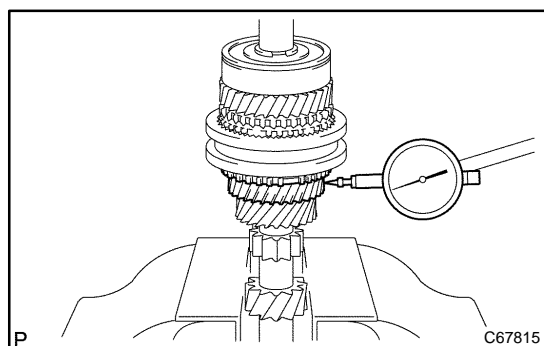

27. INSPECT 3RD GEAR RADIAL CLEARANCE

- (a) Using a dial indicator, measure the 3rd gear radial clearance.

3rd gear radial clearance:

	Standard clearance: mm (in.)	Maximum clearance: mm (in.)
KOYO made	0.015 - 0.058 (0.0006 - 0.0023)	0.058 (0.0023)
NSK made	0.015 - 0.056 (0.0006 - 0.0022)	0.056 (0.0022)

If the clearance exceeds the maximum, replace the gear, needle roller bearing or shaft.

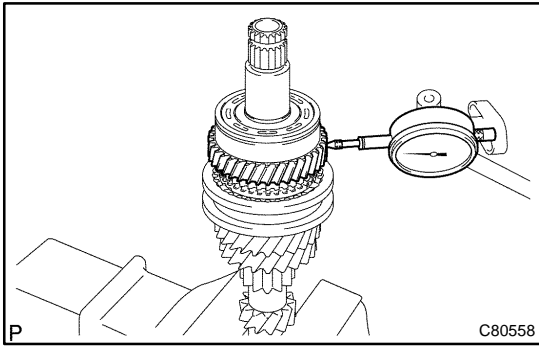

28. INSPECT 4TH GEAR RADIAL CLEARANCE

(a) Using a dial indicator, measure the 4th gear radial clearance.

4th gear radial clearance:

	Standard clearance: mm (in.)	Maximum clearance: mm (in.)
KOYO made	0.015 - 0.058 (0.0006 - 0.0023)	0.058 (0.0023)
NSK made	0.015 - 0.056 (0.0006 - 0.0022)	0.056 (0.0022)

If the clearance exceeds the maximum, replace the gear, needle roller bearing or shaft.

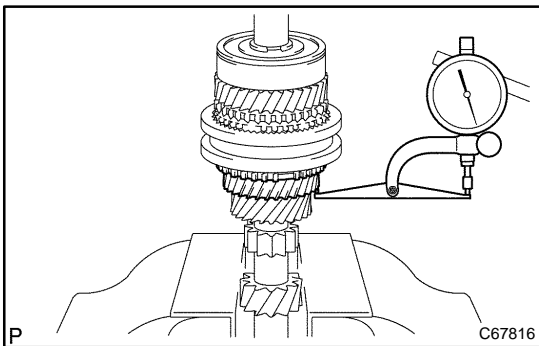

29. INSPECT 3RD GEAR THRUST CLEARANCE

(a) Using a dial indicator, measure the 3rd gear thrust clearance.

3rd gear thrust clearance:

Standard clearance: mm (in.)	Maximum clearance: mm (in.)
0.10 - 0.35 (0.0039 - 0.0138)	0.35 (0.0138)

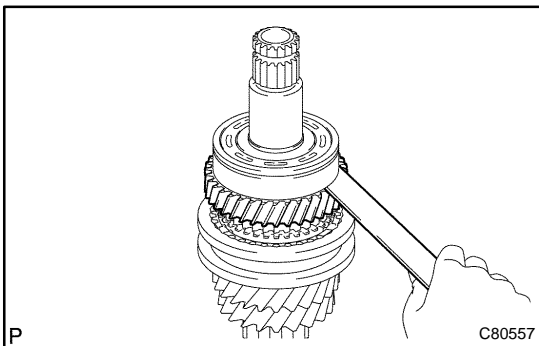

30. INSPECT 4TH GEAR THRUST CLEARANCE

(a) Using a feeler gauge, measure the 4th gear thrust clearance.

4th gear thrust clearance:

Standard clearance: mm (in.)	Maximum clearance: mm (in.)
0.10 - 0.55 (0.0039 - 0.0217)	0.55 (0.0217)

OUTPUT SHAFT ASSY (C59) COMPONENTS

41071-01

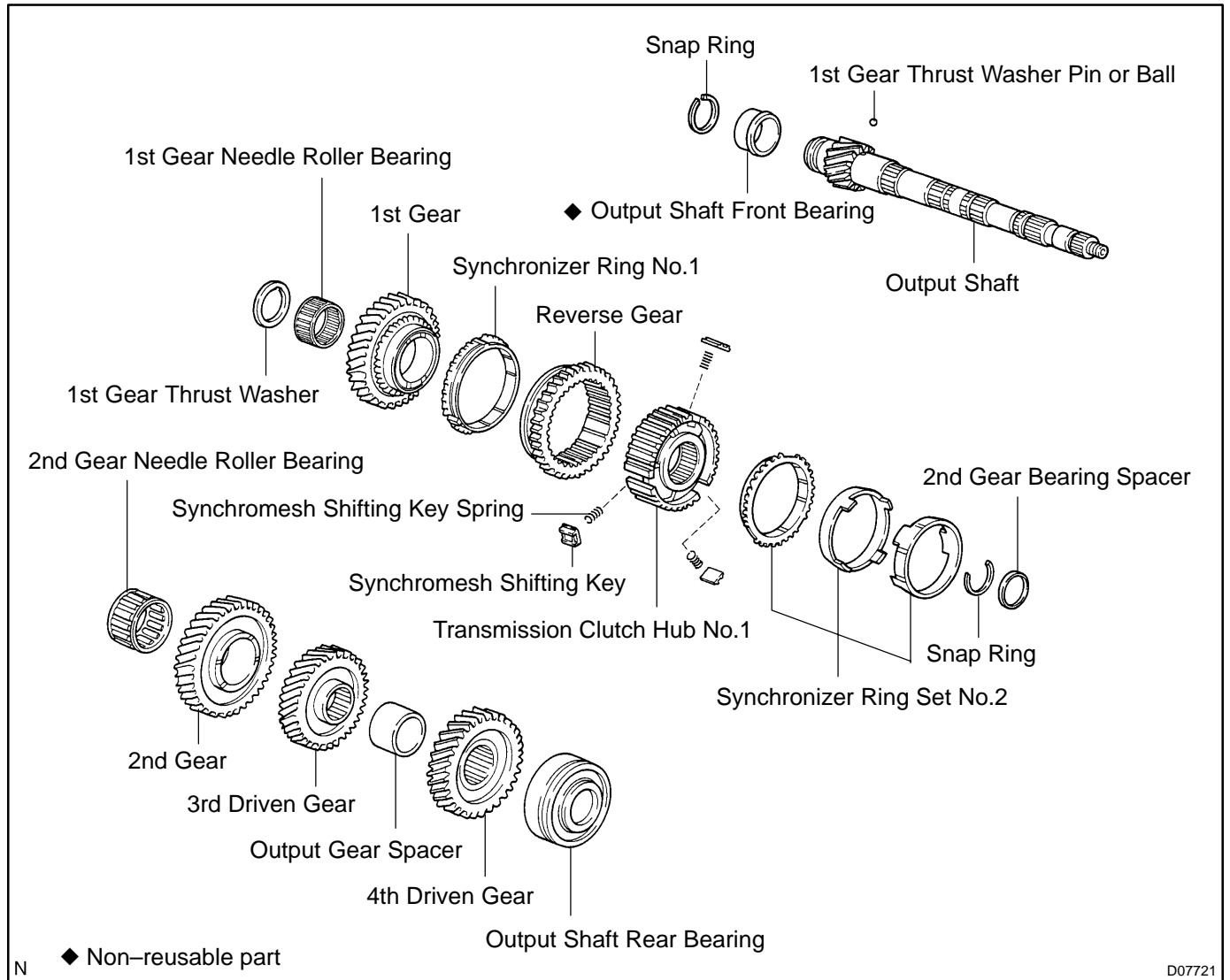

OVERHAUL

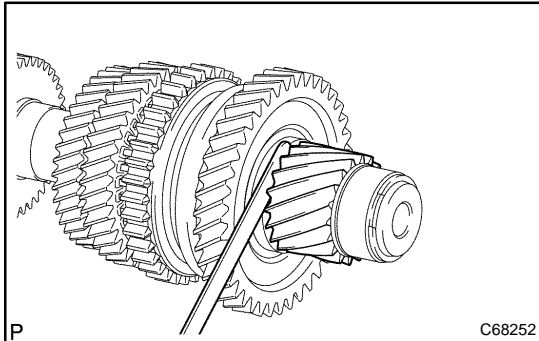

1. INSPECT 1ST GEAR THRUST CLEARANCE

- (a) Using a feeler gauge, measure the 1st gear thrust clearance.

Standard clearance:

0.10 – 0.40 mm (0.0039 – 0.0157 in.)

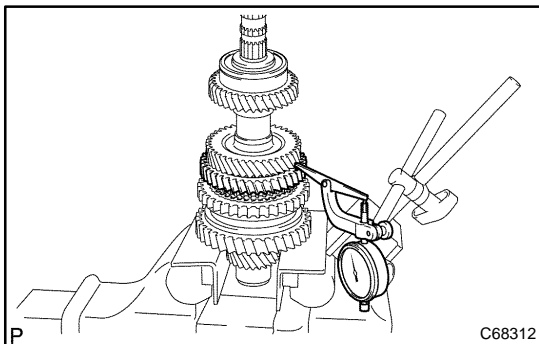

2. INSPECT 2ND GEAR THRUST CLEARANCE

- (a) Using a dial indicator, measure the 2nd gear thrust clearance.

Standard clearance:

0.10 – 0.45 mm (0.0039 – 0.0177 in.)

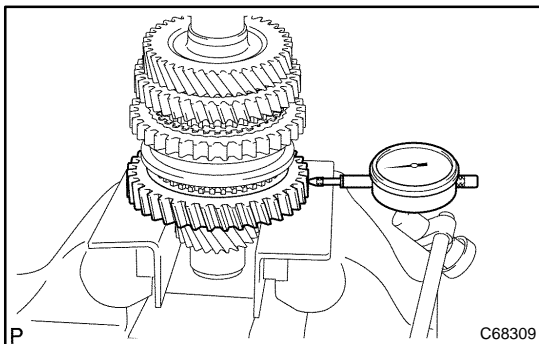

3. INSPECT 1ST GEAR RADIAL CLEARANCE

- (a) Using a dial indicator, measure the 1st gear radial clearance.

Standard clearance:

Bearing	Clearance: mm (in.)
KOYO made	0.015 – 0.058 (0.0006 – 0.0023)
NSK made	0.015 – 0.056 (0.0006 – 0.0022)

If the clearance is out of specification, replace the 1st gear needle roller bearing.

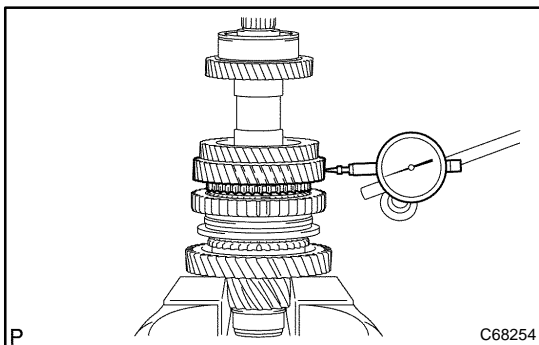

4. INSPECT 2ND GEAR RADIAL CLEARANCE

- (a) Using a dial indicator, measure the 2nd gear radial clearance.

Standard clearance:

Bearing	Clearance: mm (in.)
KOYO made	0.015 – 0.058 (0.0006 – 0.0023)
NSK made	0.015 – 0.056 (0.0006 – 0.0022)

If the clearance is out of specification, replace the 2nd gear needle roller bearing.

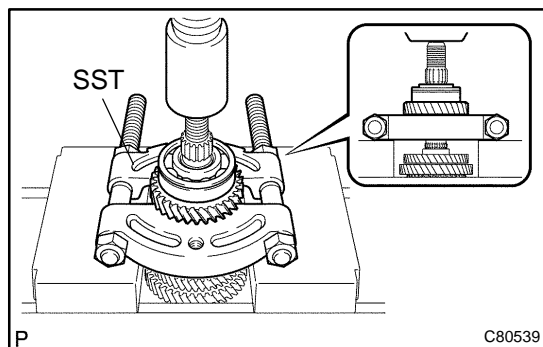
**5. REMOVE 4TH DRIVEN GEAR**

- (a) Using SST and a press, remove the output shaft rear bearing with 4th driven gear from the output shaft.
SST 09950-00020

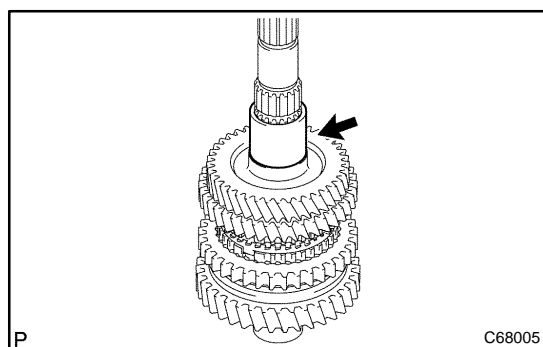
**6. REMOVE OUTPUT GEAR SPACER**

- (a) Remove the output gear spacer from the output shaft.

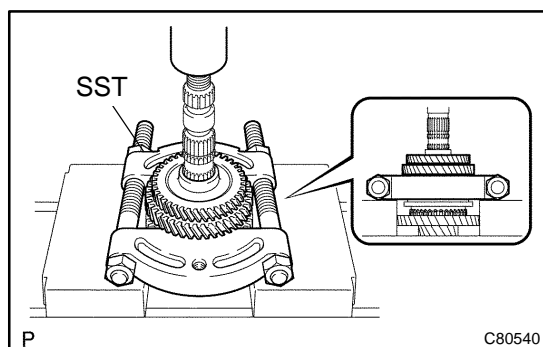
**7. REMOVE 2ND GEAR**

- (a) Using SST and a press, remove the 3rd driven gear with 2nd gear from the output shaft.
SST 09950-00020

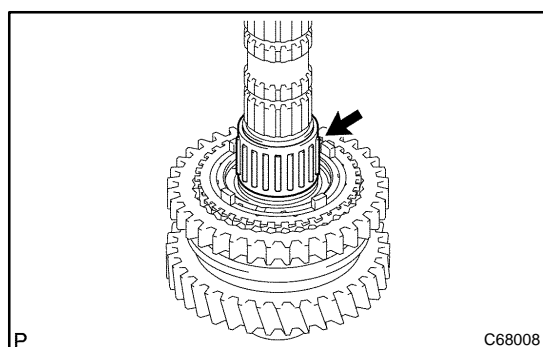
**8. REMOVE 2ND GEAR NEEDLE ROLLER BEARING**

- (a) Remove the 2nd gear needle roller bearing from the output shaft.

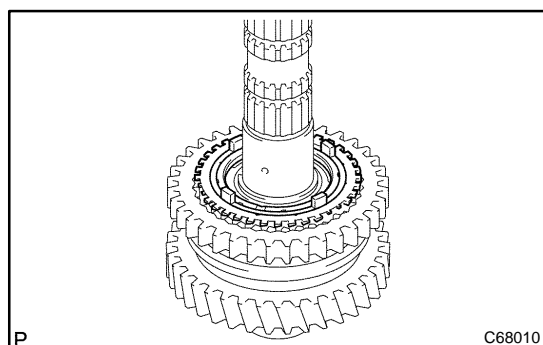
**9. REMOVE SYNCHRONIZER RING SET NO.2**

- (a) Remove the synchronizer ring set No.2 from the output shaft.

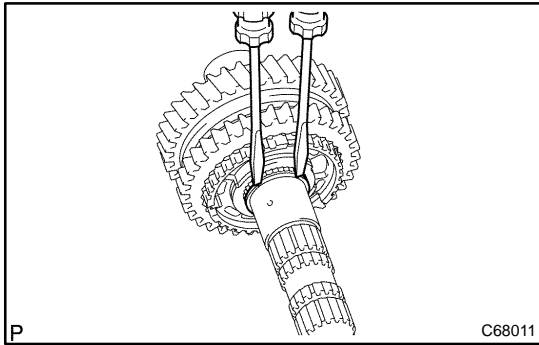
**10. REMOVE 1ST GEAR**

- (a) Using 2 screwdrivers and a hammer, tap out the snap ring.

HINT:

Using a waste to prevent the snap ring from being scattered.

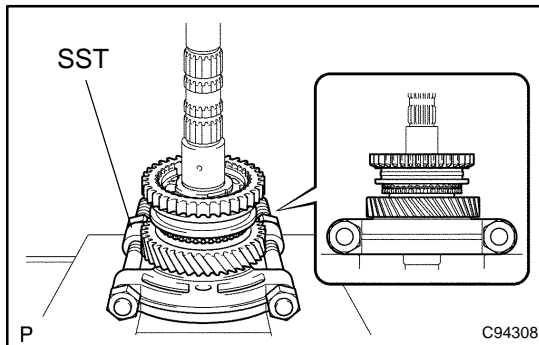

- (b) Using SST and a press, remove the transmission clutch hub No.1 with 1st gear from the output shaft.

SST 09950-00020

NOTICE:

- Do not tighten SST excessively.
- Support the input shaft by hand so that it will not be dropped off.

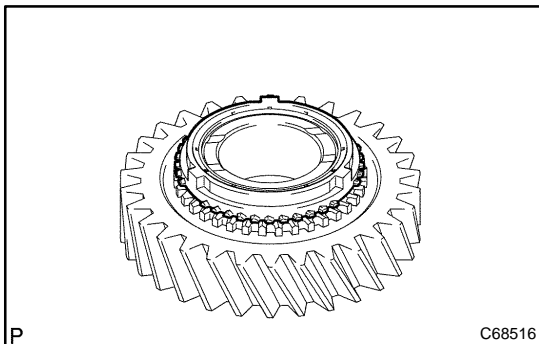
**11. REMOVE SYNCHRONIZER RING NO.1**

- (a) Remove the synchronizer ring No.1 from the 1st gear.

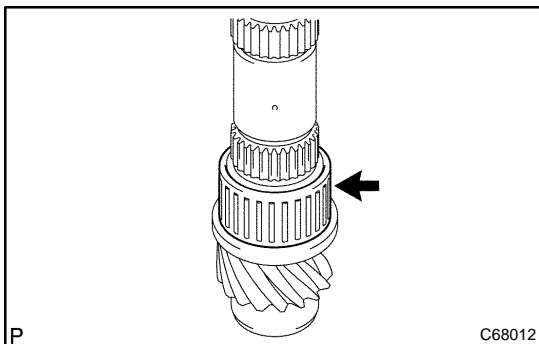
**12. REMOVE 1ST GEAR NEEDLE ROLLER BEARING**

- (a) Remove the 1st gear needle roller bearing from the output shaft.

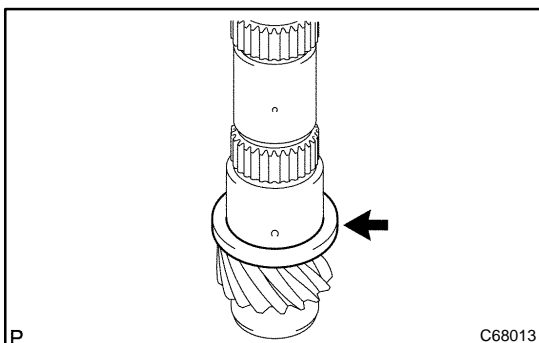
**13. REMOVE 1ST GEAR THRUST WASHER**

- (a) Remove the 1st gear thrust washer from the output shaft.

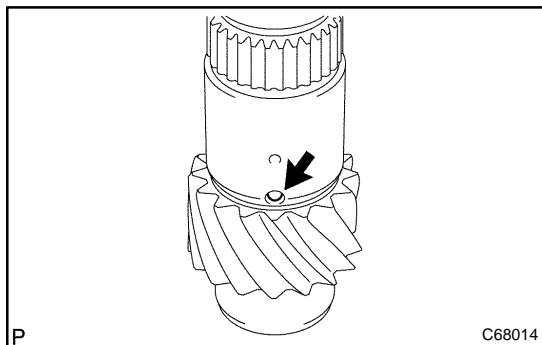

- 14. REMOVE 1ST GEAR THRUST WASHER PIN OR BALL**
 (a) Remove the 1st gear thrust washer pin or ball from the output shaft.

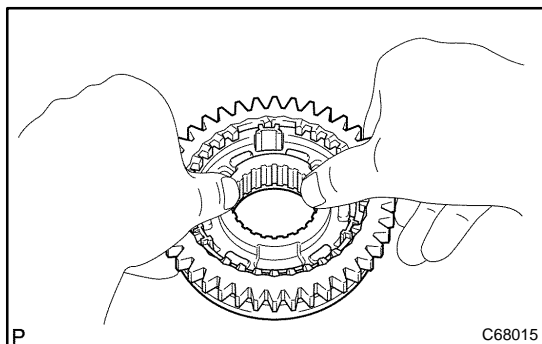

- 15. REMOVE REVERSE GEAR**
 (a) Remove the 3 synchromesh shifting keys, 3 synchromesh shifting key springs and reverse gear.

NOTICE:

Using a waste to prevent the synchromesh shifting key and spring from being scattered.

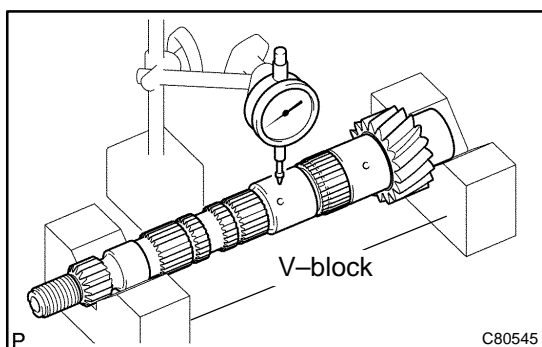
**16. INSPECT OUTPUT SHAFT**

- (a) Using a dial indicator and 2 V-blocks, measure the shaft runout.

Maximum runout: 0.015 mm (0.0006 in.)

If the runout exceeds the maximum, replace the output shaft.

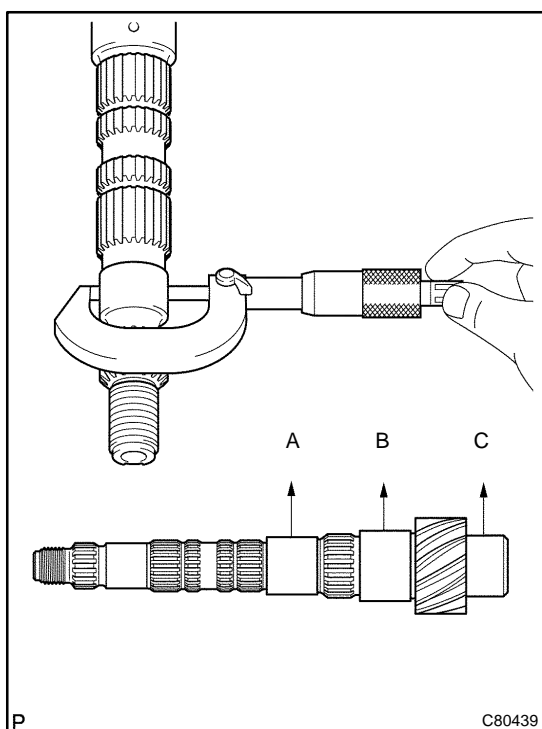

- (b) Using a micrometer, measure the outer diameter of the output shaft journal surface.

Outer diameter:

Part A: 31.985 mm (1.2592 in.)

Part B: 37.985 mm (1.4955 in.)

Part C: 32.985 mm (1.2986 in.)

If the outer diameter is below the minimum, replace the output shaft.

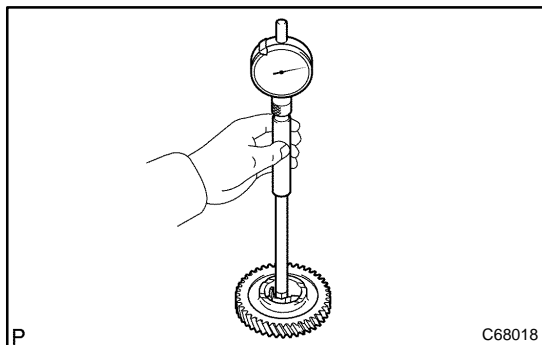
**17. INSPECT 2ND GEAR**

- (a) Using a cylinder gauge, measure the inside diameter of the 2nd gear.

Inside diameter:

New gear: mm (in.)	Maximum inside diameter: mm (in.)
38.015 - 38.031 (1.4967 - 1.4973)	38.031 (1.4973)

If the inside diameter exceeds the maximum, replace the 2nd gear.

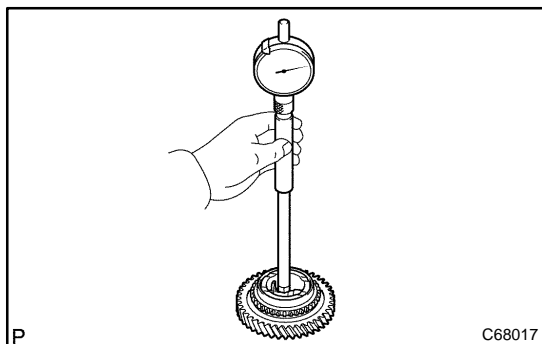
**18. INSPECT 1ST GEAR**

- (a) Using a cylinder gauge, measure the inside diameter of the 1st gear.

Inside diameter:

New gear: mm (in.)	Maximum inside diameter: mm (in.)
44.015 - 44.031 (1.7329 - 1.7335)	44.031 (1.7335)

If the inside diameter exceeds the maximum, replace the 1st gear.

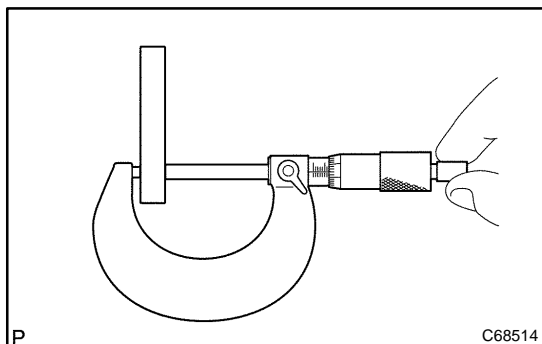
**19. INSPECT 1ST GEAR THRUST WASHER**

- (a) Using a micrometer, measure the thickness of 1st gear thrust washer.

Thickness:

New thrust washer: mm (in.)	Minimum thickness: mm (in.)
5.975 - 6.025 (0.2352 - 0.2372)	5.9755 (0.2352)

If the thickness is below the minimum, replace the 1st gear thrust washer.

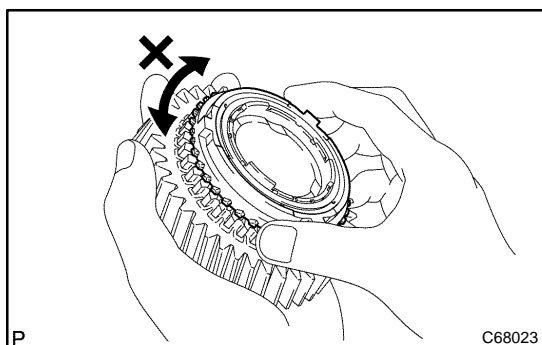
**20. INSPECT SYNCHRONIZER RING SET NO.2**

- (a) Coat the 2nd gear cone with gear oil.
Check the braking effect of the synchronizer ring set No.2.

- (b) Using a feeler gauge, measure the clearance between the synchronizer ring back and gear spline end.

Standard clearance: 0.7 - 1.3 mm (0.0276 - 0.0512 in.)

If the clearance is out of specification, replace the synchronizer ring set No.2.

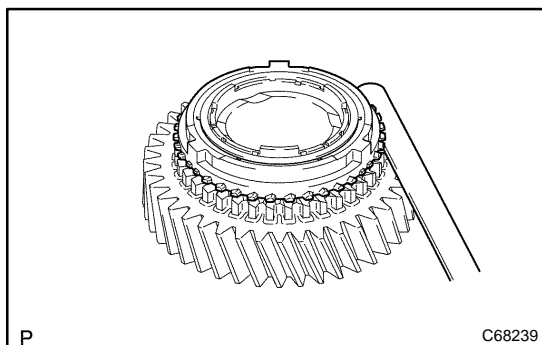

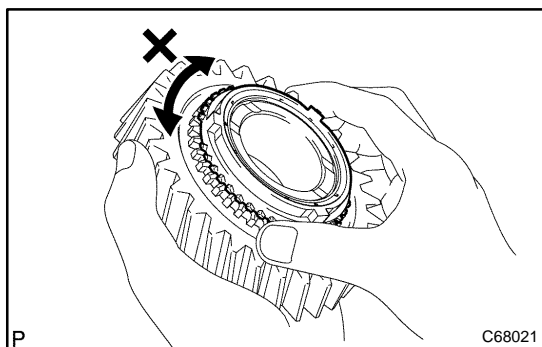
**21. INSPECT SYNCHRONIZER RING NO.1**

- (a) Coat the 1st gear cone with gear oil.
Check the braking effect of the synchronizer ring No.1.

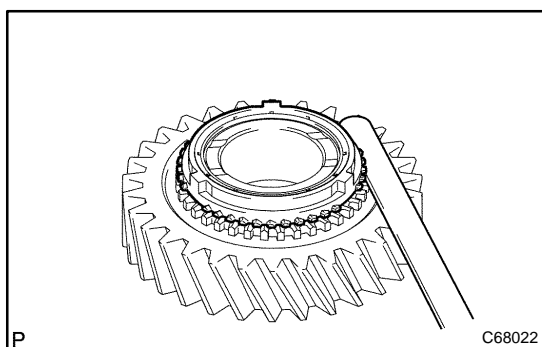

- (b) Using a feeler gauge, measure the clearance between the synchronizer ring back and gear spline end.

Standard clearance:**0.75 – 1.65 mm (0.0295 – 0.065 in.)**

If the clearance is out of specification, replace the synchronizer ring No.1.

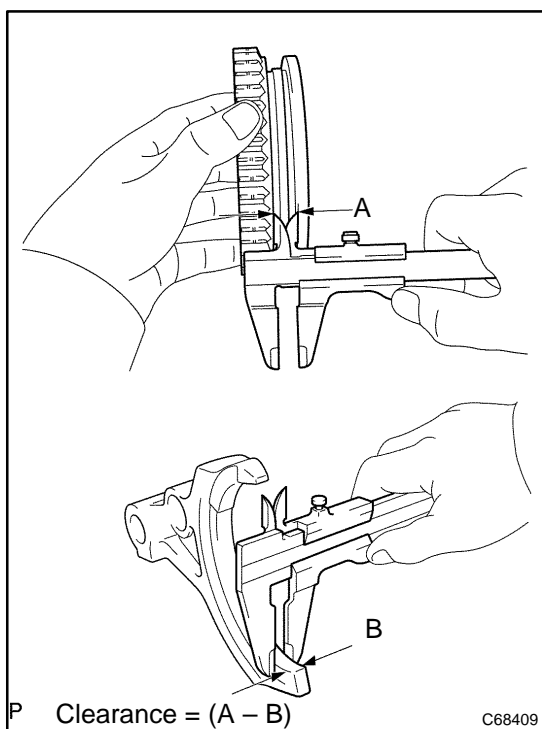
**22. INSPECT REVERSE GEAR**

- (a) Using a vernier caliper gauge, measure the clearance between reverse gear and shift fork.

Standard clearance:**0.15 – 0.35 mm (0.0059 – 0.0138 in.)**

If the clearance is out of specification, replace the reverse gear and reverse shift fork.

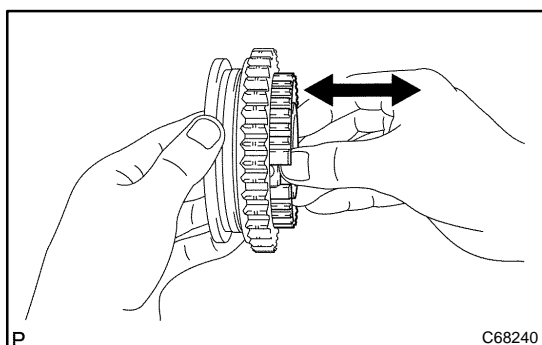
**23. INSPECT TRANSMISSION CLUTCH HUB NO.1**

- (a) Check that the transmission clutch hub No.1 and reverse gear sub-assy slides smoothly.
(b) Check that the spline gear's edges of the reverse gear sub-assy is not worn down.

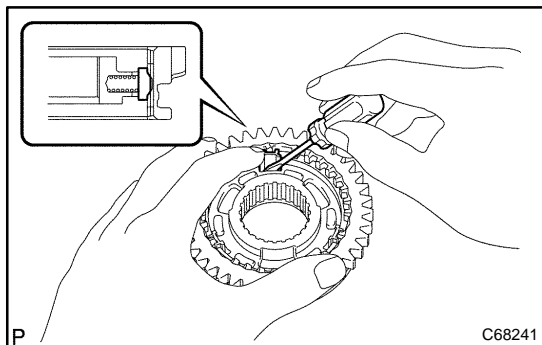

24. INSTALL REVERSE GEAR

- (a) Coat the reverse gear with gear oil, install it to the transmission clutch hub No.1.

NOTICE:

Be sure to set the reverse gear and transmission clutch hub No.1 in incorrect orientation.

- (b) Using a screwdriver, install the 3 synchromesh shifting key springs and 3 synchromesh shifting keys.

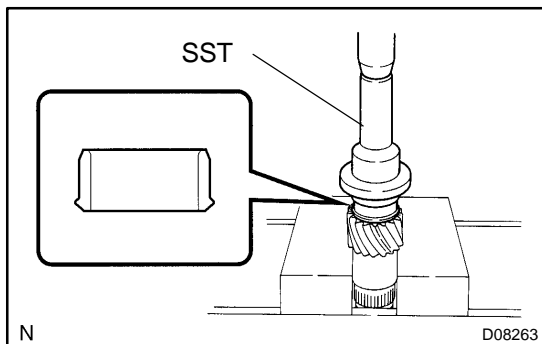

25. INSTALL OUTPUT SHAFT FRONT BEARING

- (a) Using SST and a press, install the output shaft front bearing (inner race) to the output shaft.

SST 09223-50010

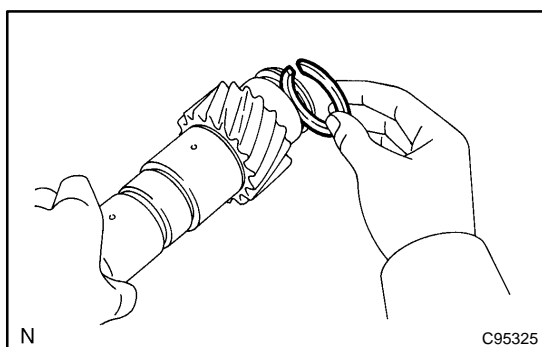

- (b) Select a snap ring from the table below that will make the thrust clearance of the output shaft front bearing (inner race) below 0.1 mm (0.0039 in.).

Snap ring thickness:

Part No.	Thickness: mm (in.)	Mark
90520 - 30032	1.85 - 1.90 (0.0728 - 0.0748)	7
90520 - 30033	1.90 - 1.95 (0.0748 - 0.0768)	8
90520 - 30002	1.95 - 2.00 (0.0768 - 0.0787)	1
90520 - 30003	2.00 - 2.05 (0.0787 - 0.0807)	2
90520 - 30004	2.05 - 2.10 (0.0807 - 0.0827)	3
90520 - 30005	2.10 - 2.15 (0.0827 - 0.0846)	4
90520 - 30006	2.15 - 2.20 (0.0846 - 0.0866)	5
90520 - 30007	2.20 - 2.25 (0.0866 - 0.0886)	6

- (c) Using a brass bar and a hammer, tap in the snap ring.

NOTICE:

Take care not to damage the journal surface of the output shaft.

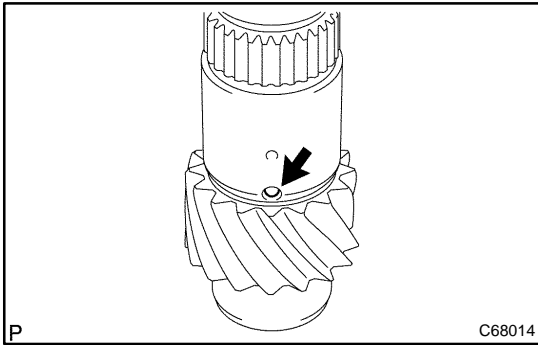
**26. INSTALL 1ST GEAR THRUST WASHER PIN OR BALL**

- (a) Coat the 1st gear thrust washer pin or ball with MP grease, install it to the output shaft.

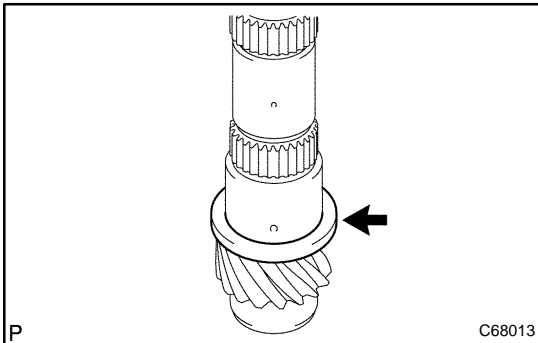
**27. INSTALL 1ST GEAR THRUST WASHER**

- (a) Coat the 1st gear thrust washer with gear oil, install it to the output shaft.

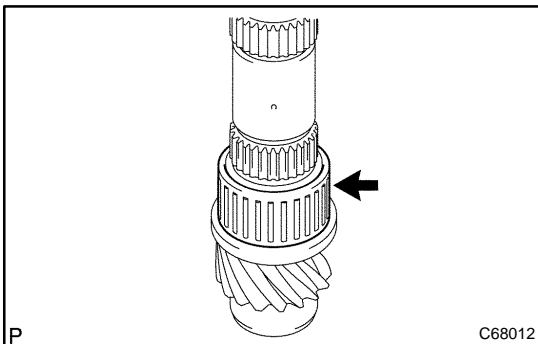
**28. INSTALL 1ST GEAR NEEDLE ROLLER BEARING**

- (a) Coat the 1st gear needle roller bearing with gear oil, install it to the output shaft.

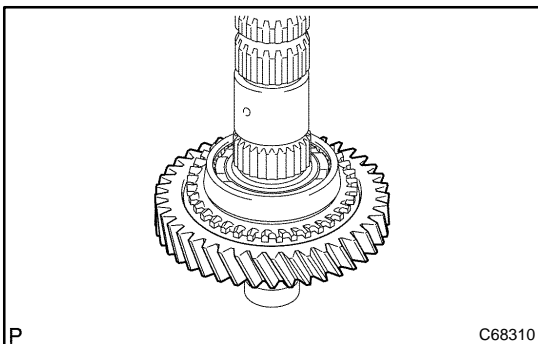
**29. INSTALL 1ST GEAR**

- (a) Coat the 1st gear with gear oil, install it to the output shaft.

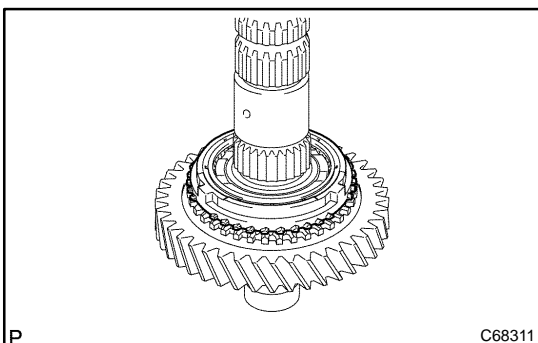
**30. INSTALL SYNCHRONIZER RING NO.1**

- (a) Coat the synchronizer ring No.1 with gear oil, install it to the 1st gear.

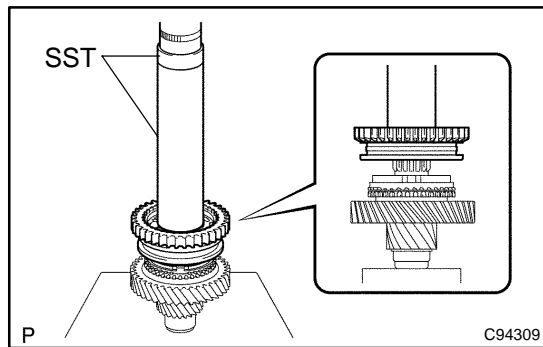

31. INSTALL TRANSMISSION CLUTCH HUB NO.1

- (a) Using SST and a press, install the transmission clutch hub No.1 to the output shaft.

SST 09316-60011 (09316-00031)

NOTICE:

The 1st gear can be turned.

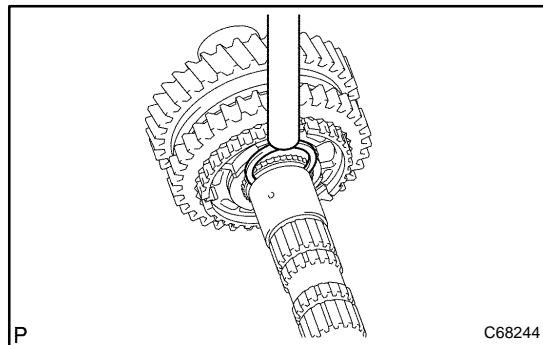

- (b) Select a snap ring from the table below that will make the thrust clearance of the transmission clutch hub No.1 below 0.1 mm (0.0039 in.).

Snap ring thickness:

Part No.	Thickness: mm (in.)	Mark
90520-29018	2.50 (0.0984)	A
90520-29019	2.56 (0.1008)	B
90520-29020	2.62 (0.1031)	C
90520-29021	2.68 (0.1055)	D
90520-29022	2.74 (0.1079)	E
90520-29023	2.80 (0.1102)	F

- (c) Using a brass bar and a hammer, install the snap ring to the output shaft.

NOTICE:

Take care not to damage the journal surface of the output shaft.

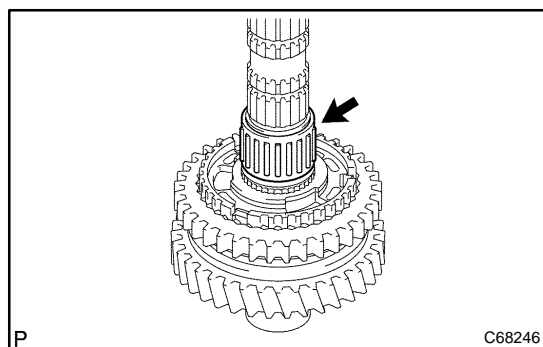

32. INSTALL 2ND GEAR NEEDLE ROLLER BEARING

- (a) Coat the 2nd gear needle roller bearing with gear oil, install it to the output shaft.

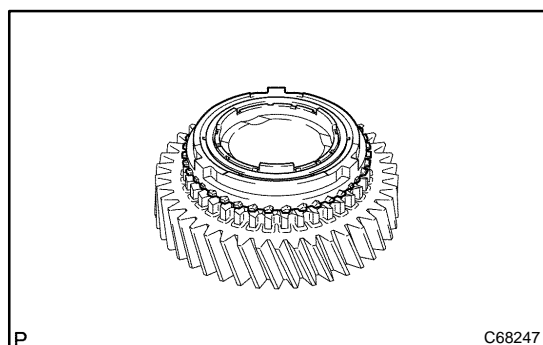

33. INSTALL SYNCHRONIZER RING SET NO.2

- (a) Coat the synchronizer ring set No.2 with gear oil, install it to the 2nd gear.

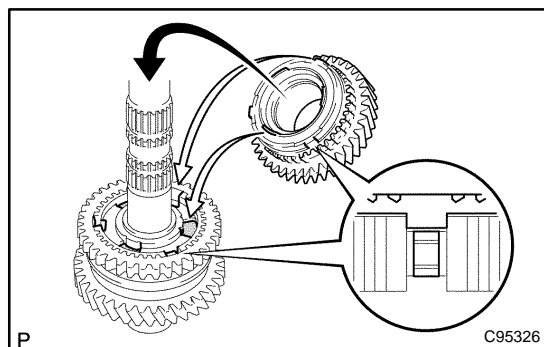
**34. INSTALL 2ND GEAR**

- (a) Coat the 2nd gear with gear oil, install it to the output shaft.

NOTICE:

Fit the synchronizer inner ring claws into the slots in the transmission clutch hub No.1.

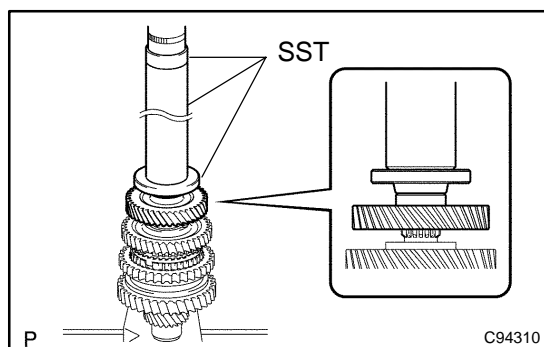
**35. INSTALL 3RD DRIVEN GEAR**

- (a) Using SST and a press, install the 3rd driven gear to the output shaft.

SST 09309-36100 (09309-03610), 09608-00071,
09950-60010 (09951-00450)

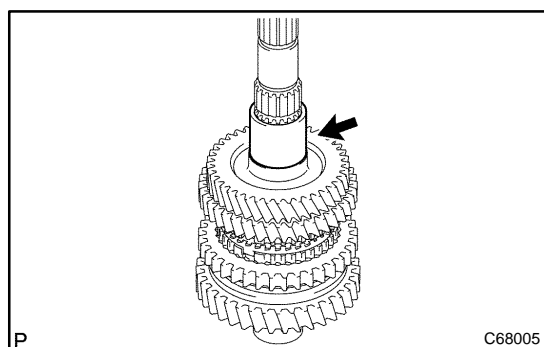
**36. INSTALL OUTPUT GEAR SPACER**

- (a) Install the output gear spacer to the output shaft.

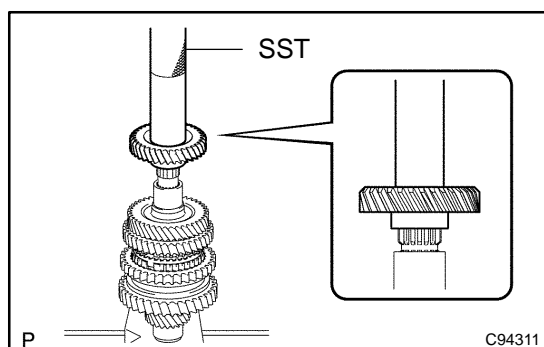
**37. INSTALL 4TH DRIVEN GEAR**

- (a) Using SST and a press, install 4th driven gear to the output shaft.

SST 09612-22011

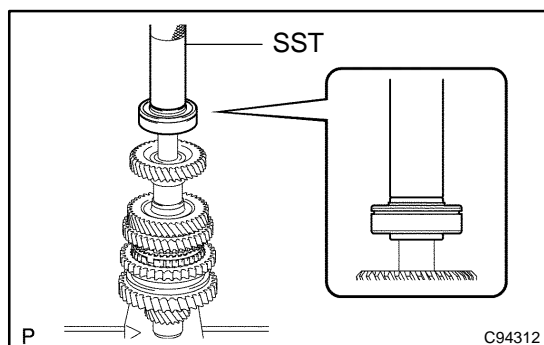
**38. INSTALL OUTPUT SHAFT REAR BEARING**

- (a) Using SST and a press, install output shaft rear bearing to the output shaft.

SST 09612-22011

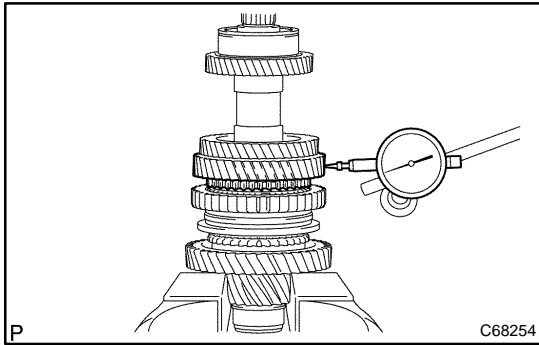
**39. INSPECT 2ND GEAR RADIAL CLEARANCE**

- (a) Using a dial indicator, measure the 2nd gear radial clearance.

Standard clearance:

Bearing	Clearance: mm (in.)
KOYO made	0.015 - 0.058 (0.0006 - 0.0023)
NSK made	0.015 - 0.056 (0.0006 - 0.0022)

If the clearance is out of specification, replace the 2nd gear needle roller bearing.

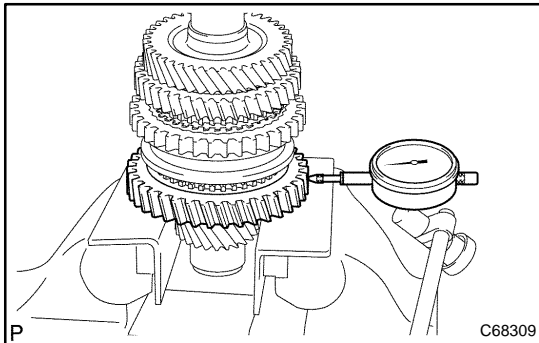
**40. INSPECT 1ST GEAR RADIAL CLEARANCE**

- (a) Using a dial indicator, measure the 1st gear radial clearance.

Standard clearance:

Bearing	Clearance: mm (in.)
KOYO made	0.015 - 0.058 (0.0006 - 0.0023)
NSK made	0.015 - 0.056 (0.0006 - 0.0022)

If the clearance is out of specification, replace the 1st gear needle roller bearing.

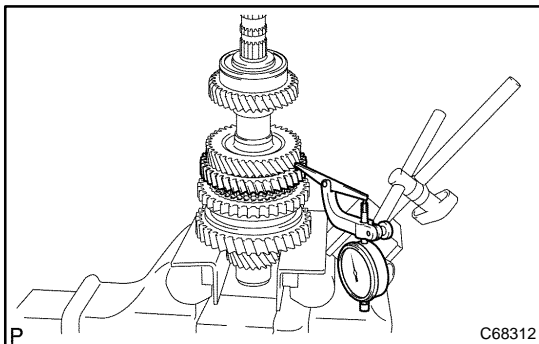
**41. INSPECT 2ND GEAR THRUST CLEARANCE**

- (a) Using a dial indicator, measure the 2nd gear thrust clearance.

Standard clearance:

0.10 - 0.45 mm (0.0039 - 0.0177 in.)

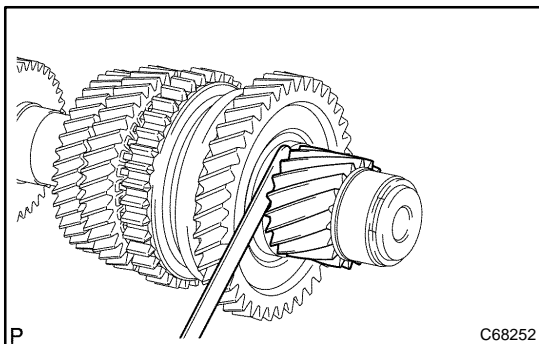
**42. INSPECT 1ST GEAR THRUST CLEARANCE**

- (a) Using a feeler gauge, measure the 1st gear thrust clearance.

Standard clearance:

0.10 - 0.40 mm (0.0039 - 0.0157 in.)

DIFFERENTIAL CASE ASSY (C59)

COMPONENTS

4107K-01

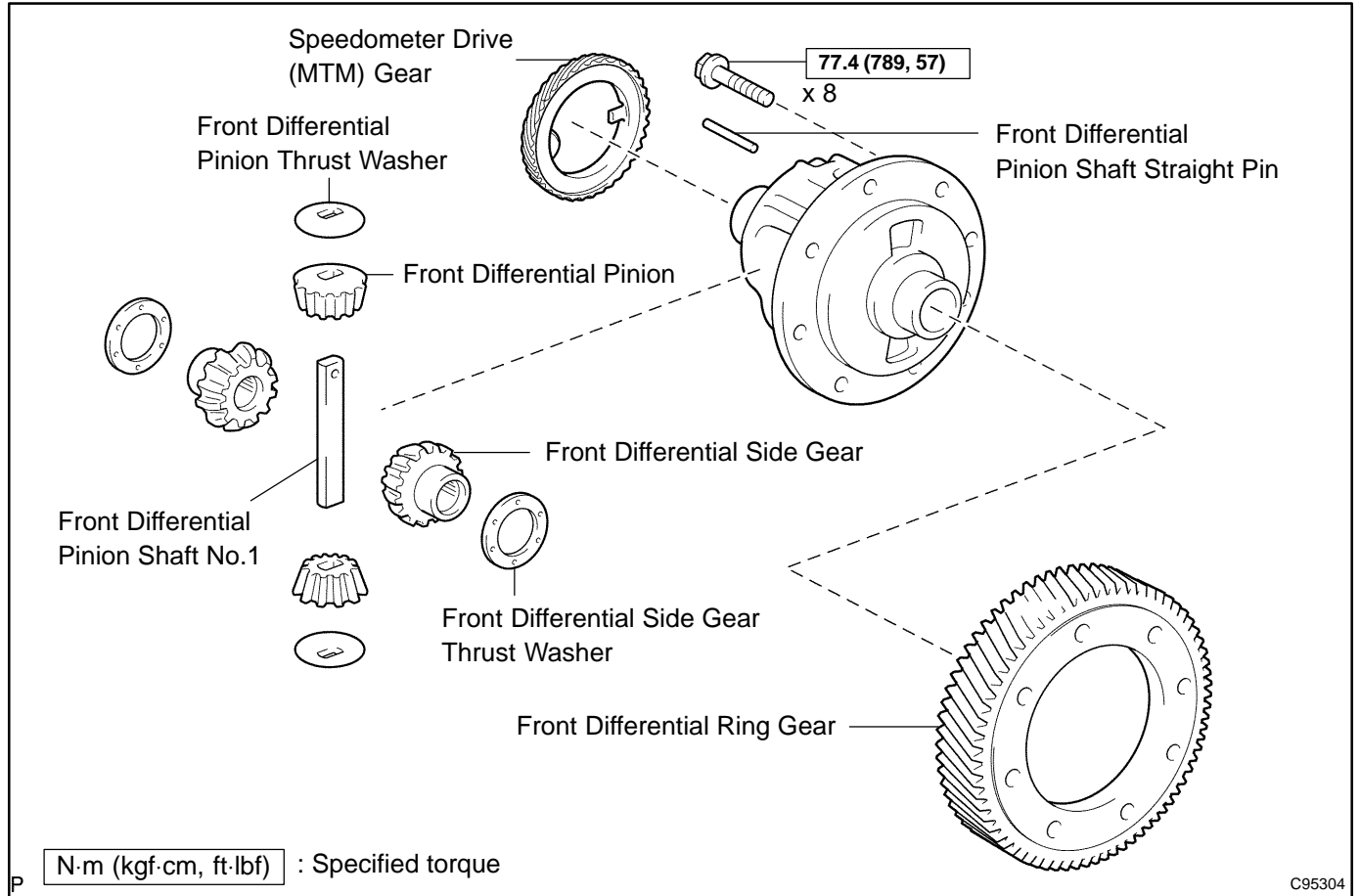

C95304

OVERHAUL

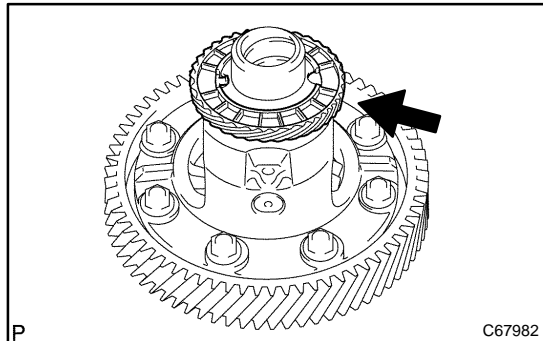

1. REMOVE SPEEDOMETER DRIVE (MTM) GEAR

- (a) Remove the speedometer drive (MTM) gear from the front differential case.

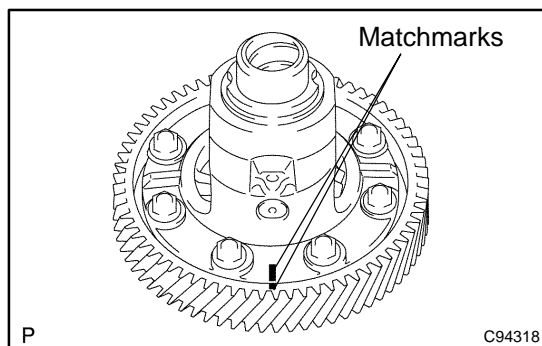

2. REMOVE FRONT DIFFERENTIAL RING GEAR

- (a) Place matchmarks on the front differential ring gear and front differential case.

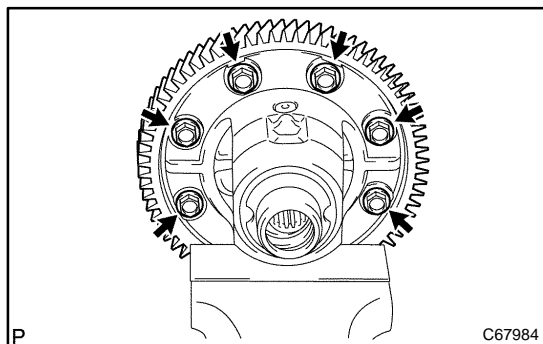

- (b) Remove the 8 bolts. Using a hammer, remove the front differential ring gear.

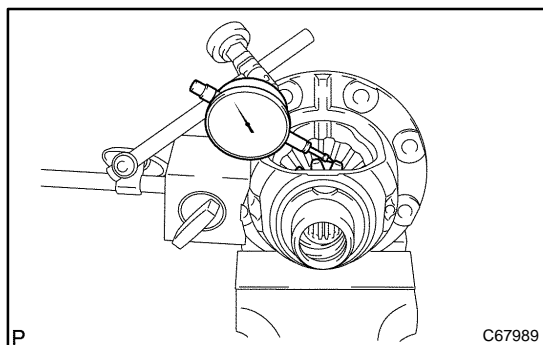

3. INSPECT FRONT DIFFERENTIAL SIDE GEAR BACKLASH

- (a) Fixing the front differential pinion from the front differential case side. Using a dial indicator, measure the backlash of the front differential side gear.

Standard backlash:

0.05 – 0.20 mm (0.0020 – 0.0079 in.)

If the backlash is not within the specification, install the connect side gear thrust washers.

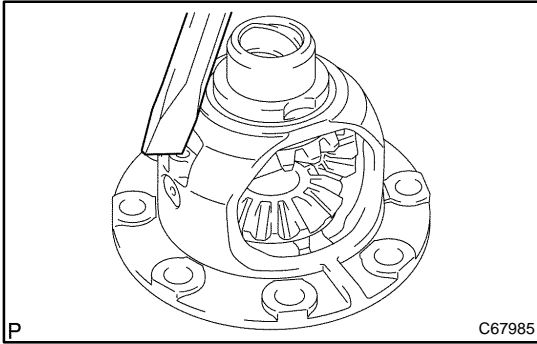

4. REMOVE FRONT DIFFERENTIAL PINION SHAFT STRAIGHT PIN

- (a) Using a chisel and a hammer, loosen the staked part of the front differential case.

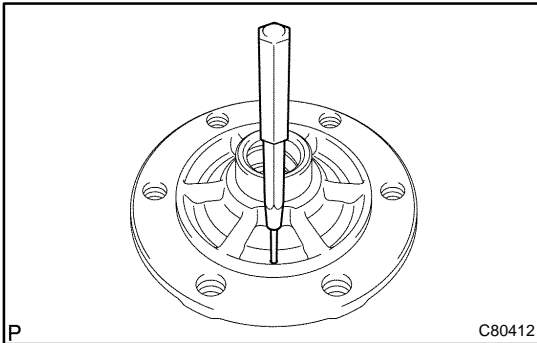

- (b) Using a pin punch (ϕ 3 mm) and a hammer, remove the front differential pinion shaft straight pin from the front differential case.

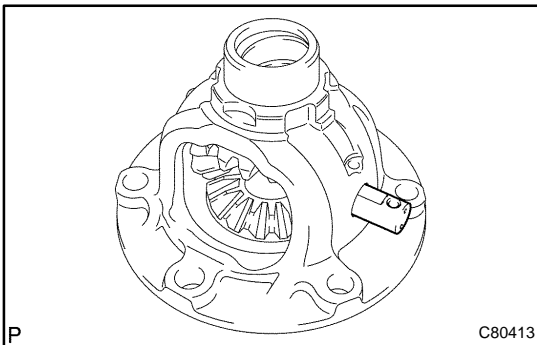

5. REMOVE FRONT DIFFERENTIAL PINION SHAFT NO.1

- (a) Remove the front differential pinion shaft No.1 from the front differential case.

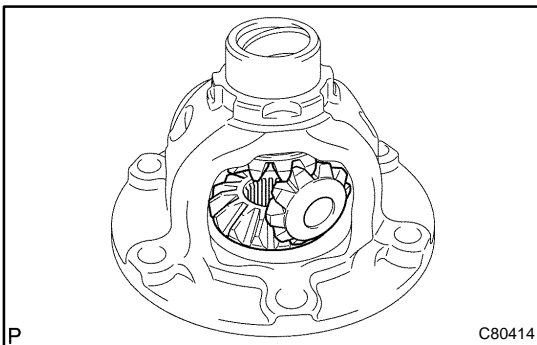

6. REMOVE FRONT DIFFERENTIAL SIDE GEAR

- (a) Remove the 2 front differential pinions, 2 front differential pinion thrust washers, 2 front differential side gear thrust washers and 2 front differential side gears from the front differential case.

HINT:

Turning the front differential pinion, remove the 2 pinions and side gear.

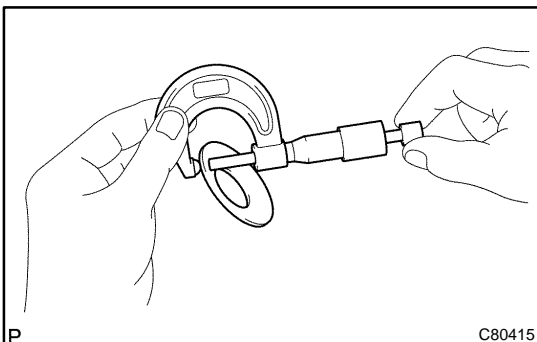

7. INSPECT FRONT DIFFERENTIAL PINION THRUST WASHER

- (a) Using a micrometer, measure the thickness of the front differential pinion thrust washer.

Minimum thickness: 0.92 mm (0.0362 in.)

If the clearance is below the minimum, replace the front differential pinion thrust washer.

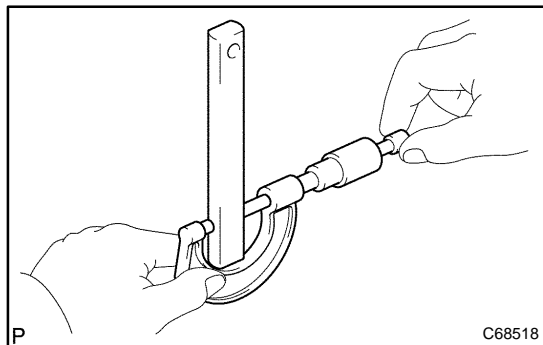

8. INSPECT FRONT DIFFERENTIAL PINION SHAFT NO.1

- (a) Using a micrometer, measure the the outer diameter of the front differential pinion shaft No.1.

Minimum outer diameter: 16.982 mm (0.6686 in.)

If the outer diameter is less than the minimum, replace the front differential pinion shaft No.1.

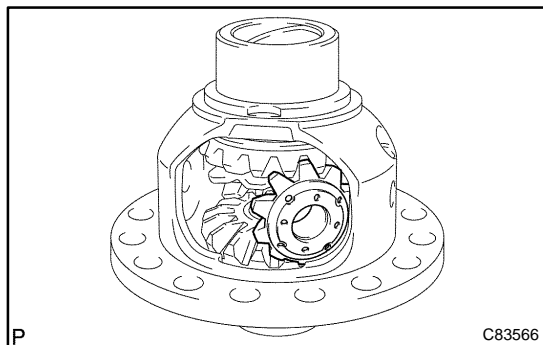

9. INSTALL FRONT DIFFERENTIAL SIDE GEAR

- (a) Coat the sliding and rotating surface of the 2 front differential side gears with MP grease.
- (b) Install the 2 front differential side gear thrust washers to the 2 front differential side gear.

HINT:

Install the front differential side gear thrust washer that has the same thickness as the removed one.

- (c) Install the 2 front differential side gears, 2 front differential pinions and 2 front differential side gear thrust washers to the front differential case.

HINT:

Turning the front differential pinion, install the 2 front differential pinions with front differential case.

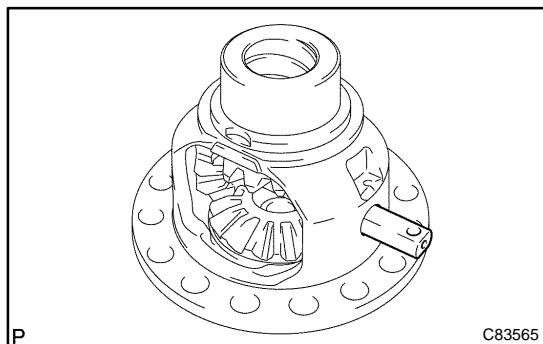

10. INSTALL FRONT DIFFERENTIAL PINION SHAFT NO.1

- (a) Coat the rotating surface of the front differential pinion shaft No.1 with gear oil.
- (b) Install the front differential pinion shaft No.1 to the front differential case so that the hole for the front differential pinion shaft straight pin is aligned with the hole in the front differential case.

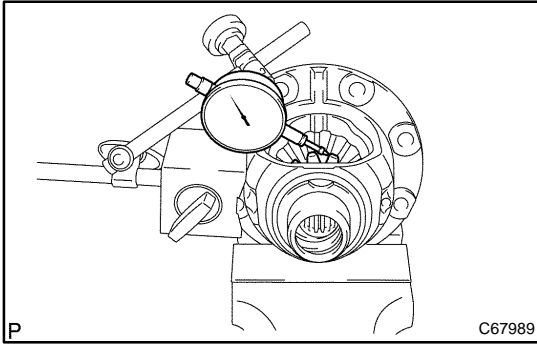

11. ADJUST FRONT DIFFERENTIAL SIDE GEAR BACKLASH

- (a) Fixing the front differential pinion to the front differential case side. Using a dial indicator, measure the front differential side gear backlash.

Standard backlash:

0.05 – 0.20 mm (0.0020 – 0.0079 in.)

If the backlash is out of specification, replace the side gear thrust washer.

Thrust washer thickness:

Part No.	Thickness: mm (in.)
41361 – 22140	0.95 (0.0374)
41361 – 22020	1.00 (0.0394)
41361 – 22150	1.05 (0.0413)
41361 – 22030	1.10 (0.0433)
41361 – 22160	1.15 (0.0453)
41361 – 22040	1.20 (0.0472)

HINT:

- Because the thrust washer does not have any identification mark, measure the front thickness with a micrometer to select a proper thrust washer.
- Select washers that has the same thickness as both the right and left.

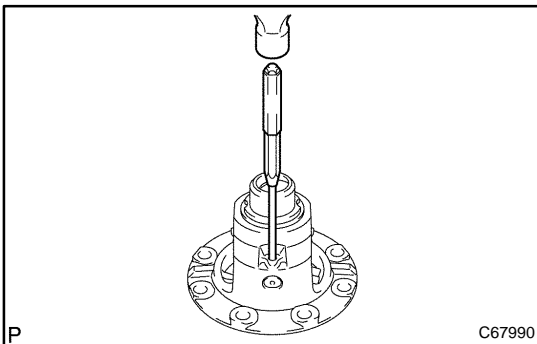

12. INSTALL FRONT DIFFERENTIAL PINION SHAFT STRAIGHT PIN

- (a) Using a pin punch (ϕ 3 mm) and a hammer, install the front differential pinion shaft straight pin to the front differential case.

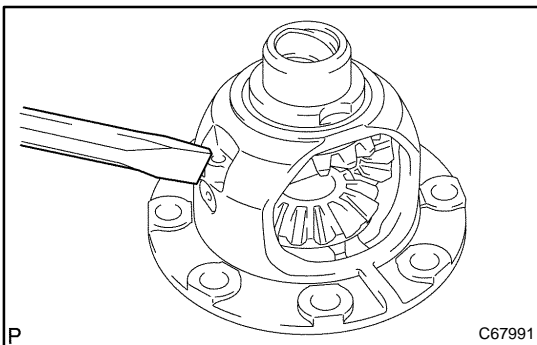

- (b) Using a chisel and a hammer, stake the front case hole.

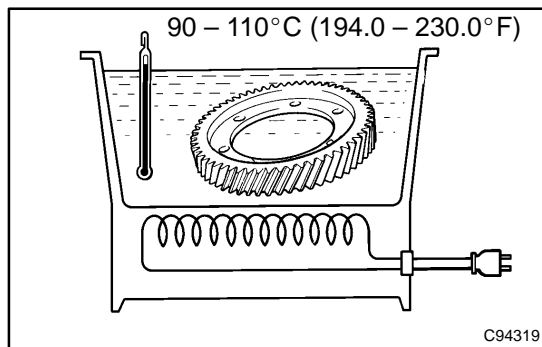
**13. INSTALL FRONT DIFFERENTIAL RING GEAR**

- (a) Using a heater, heat the front differential ring gear to 90 - 110°C (194.0 - 230.0°F)
- (b) Clean the contact surface of the front differential case.

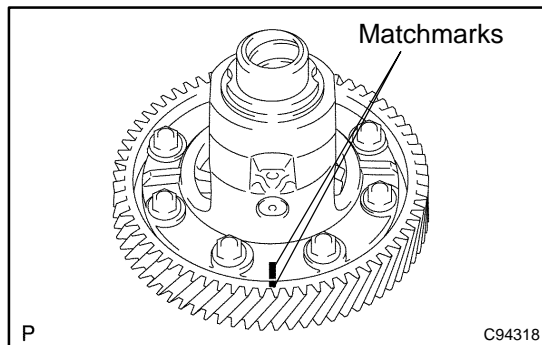

- (c) Align the both matchmarks, quickly install the 8 bolts with the front differential ring gear to the front differential case.
Torque: 77.4 N·m (789 kgf·cm, 57 ft·lbf)

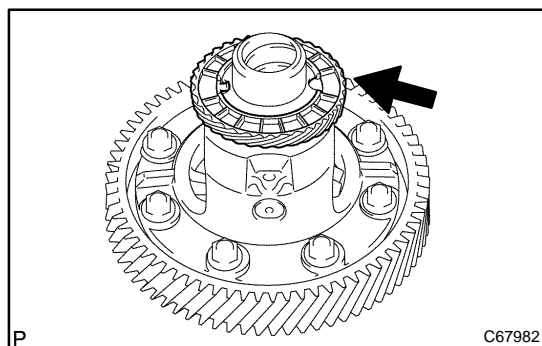
**14. INSTALL SPEEDOMETER DRIVE (MTM) GEAR**

- (a) Install the speedometer drive (MTM) gear to the front differential case.

SHIFT & SELECT LEVER SHAFT ASSY (C59) COMPONENTS

4107M-01

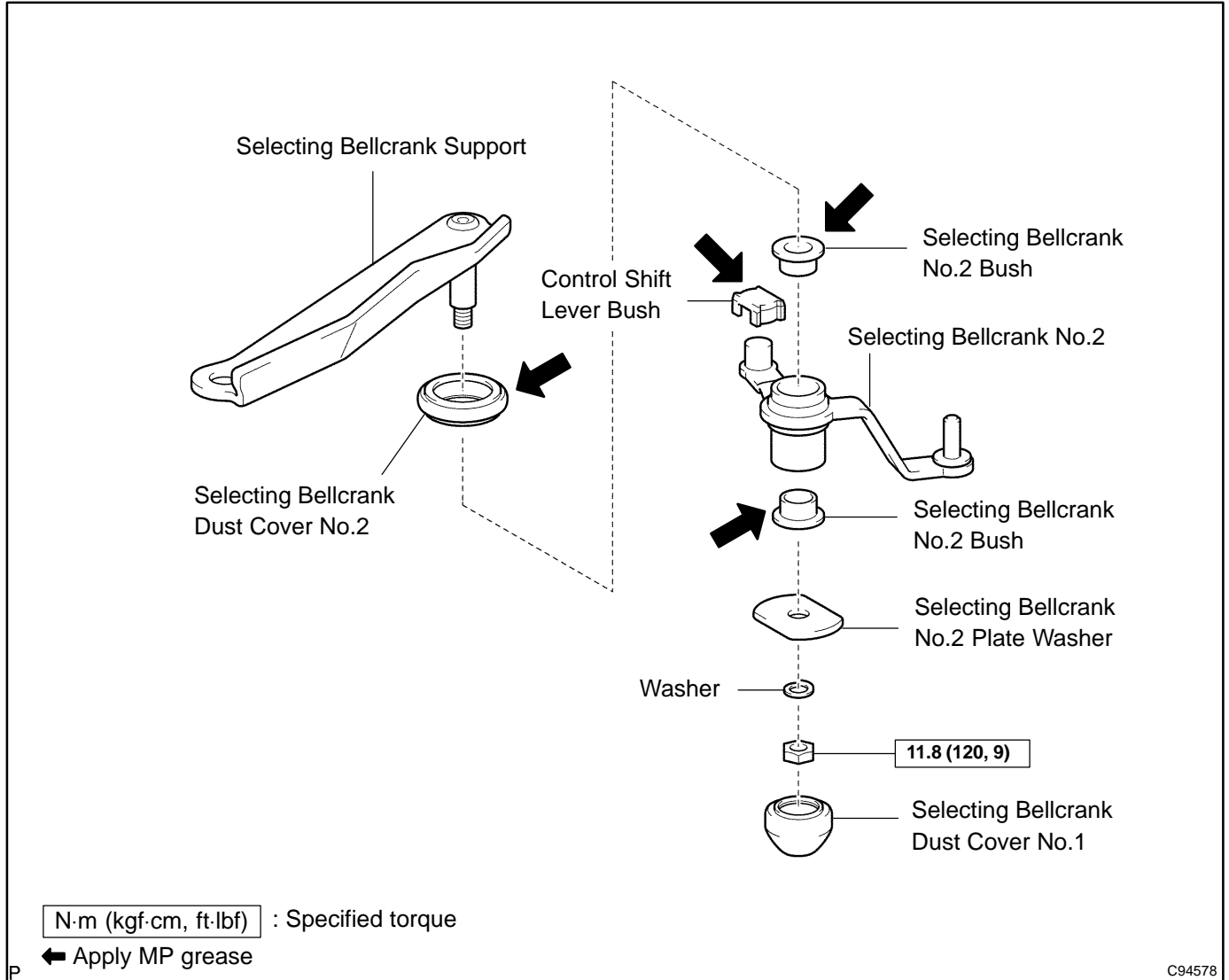

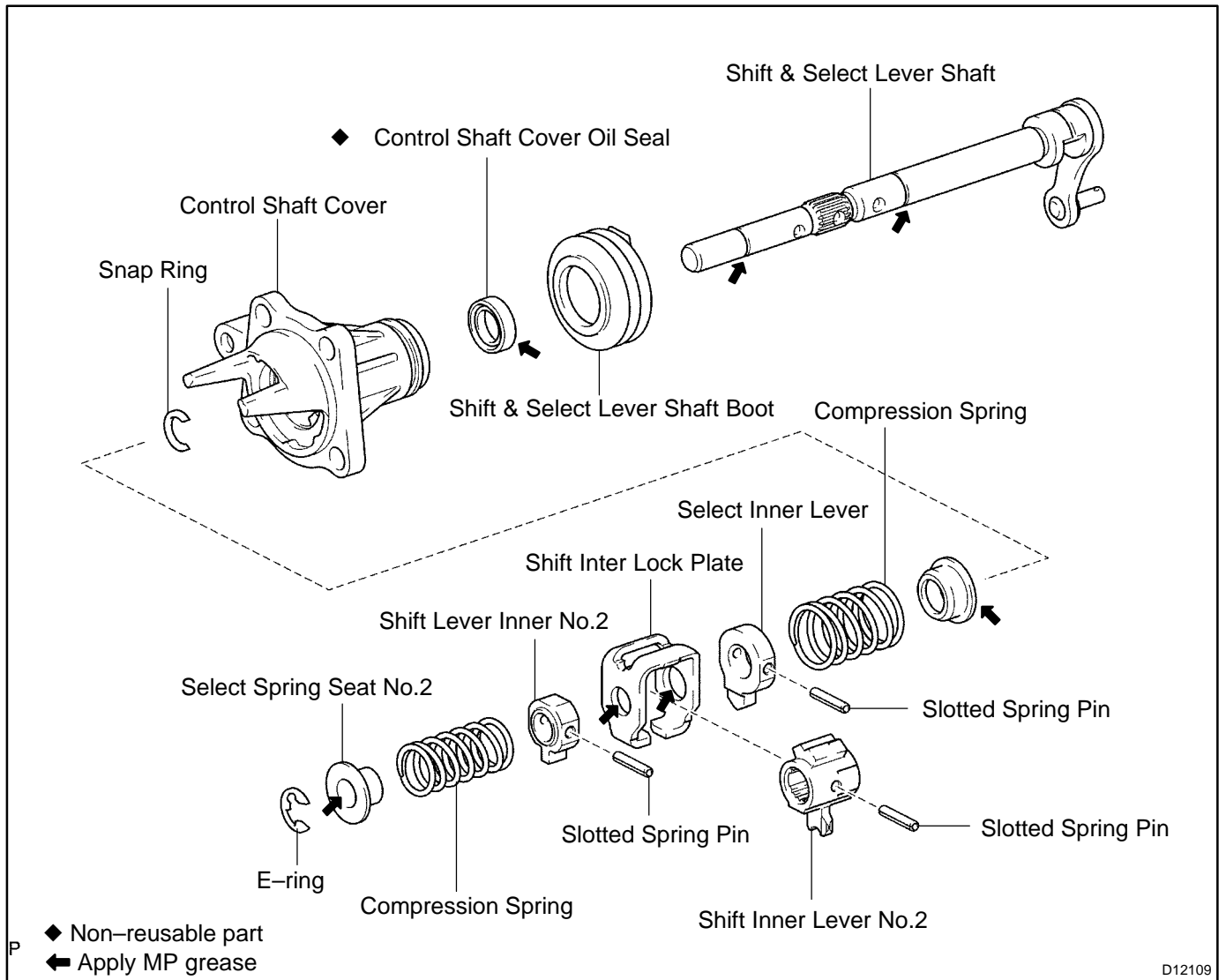

OVERHAUL

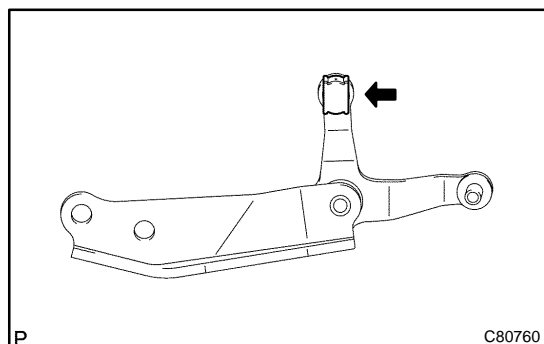
**1. REMOVE CONTROL SHIFT LEVER BUSH**

- (a) Remove the control shift lever bush from the selecting bellcrank assy.

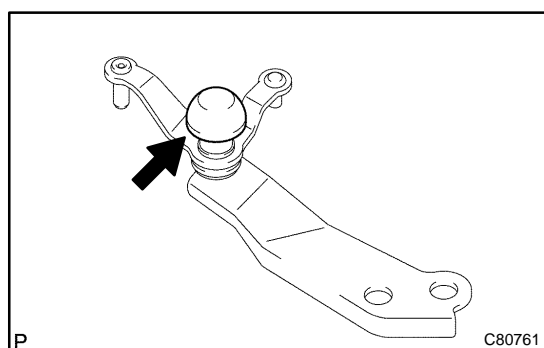
**2. REMOVE SELECTING BELLCRANK DUST COVER NO.1**

- (a) Remove the selecting bellcrank dust cover No.1 from the selecting bellcrank assy.

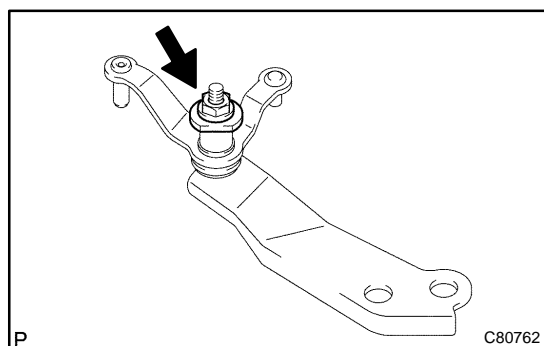
**3. REMOVE SELECTING BELL CRANK NO.2**

- (a) Remove the nut, spring washer and selecting bellcrank No.2 plate washer.
 (b) Remove the selecting bellcrank No.2 from the selecting bellcrank support.

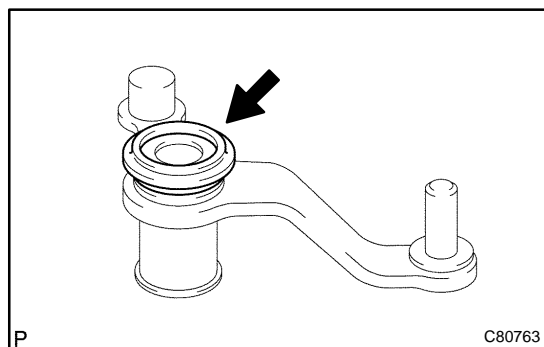
**4. REMOVE SELECTING BELLCRANK DUST COVER NO.2**

- (a) Remove the selecting bellcrank dust cover No.2 from the selecting bellcrank No.2.

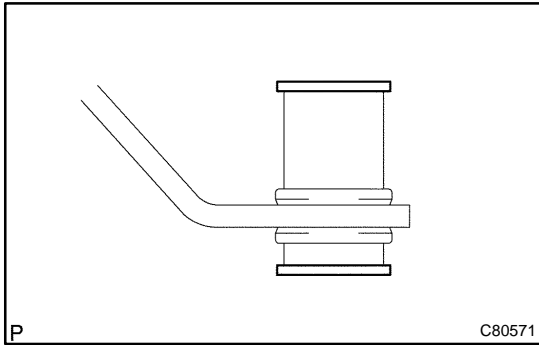

5. REMOVE SELECTING BELLCRANK NO.2 BUSH

- (a) Remove the 2 selecting bellcrank No.2 bushes from the selecting bellcrank No.2.

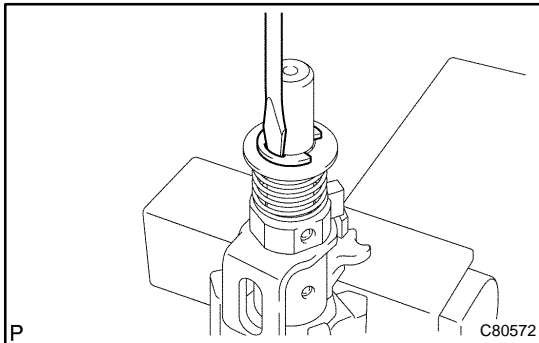

6. REMOVE SELECT SPRING SEAT NO.2

- (a) Using a screwdriver, remove the E-ring, select spring seat No.2 and select return spring No.2 from the shift & select lever shaft.

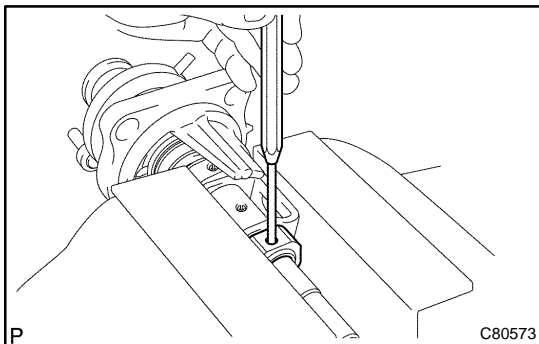

7. REMOVE SHIFT LEVER INNER NO.2

- (a) Using a pin punch (ϕ 5 mm) and a hammer, remove the slotted pin and shift lever inner No.2 from the shift & select lever shaft.

HINT:

Make sure the orientation of the shift lever inner No.2.

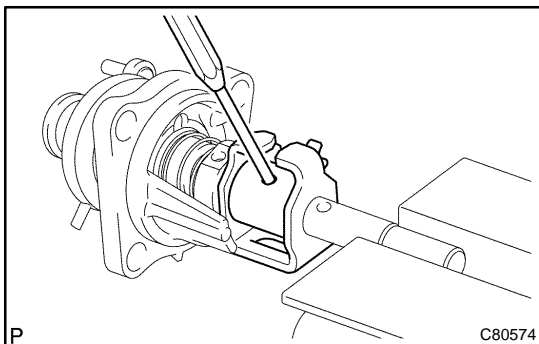

8. REMOVE SHIFT LEVER INNER NO.1

- (a) Using a pin punch (ϕ 5 mm) and a hammer, remove the slotted pin, shift lever inner No.1 and shift inter lock plate from the shift & select lever shaft.

HINT:

Make sure the orientation of the shift lever inner No.1.

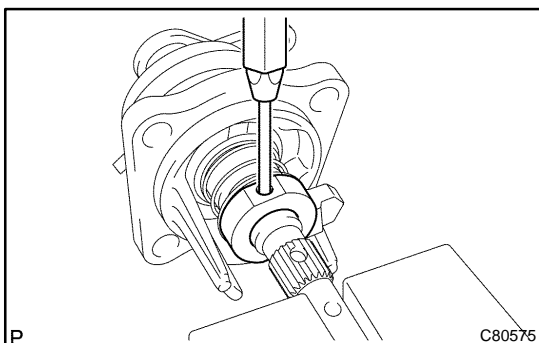

9. REMOVE SELECT INNER LEVER

- (a) Using a pin punch (ϕ 5 mm) and a hammer, remove the slotted pin, select inner lever, select return spring No.1 and select return spring seat No.1.

HINT:

Make sure the orientation of the select inner lever.

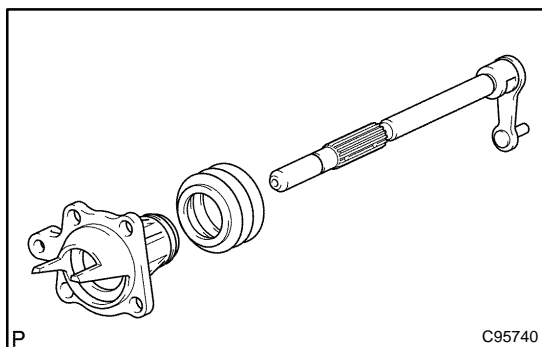
**10. REMOVE CONTROL SHAFT COVER**

- (a) Using 2 screwdrivers and a hammer, tap out the snap ring.
- (b) Remove the control shaft cover and shift & select lever shaft dust boot.

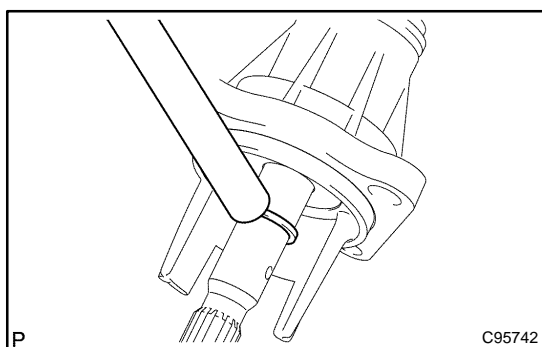
**11. REMOVE CONTROL SHAFT COVER OIL SEAL**

- (a) Using a screwdriver, remove the control shaft cover oil seal from the control shaft cover.

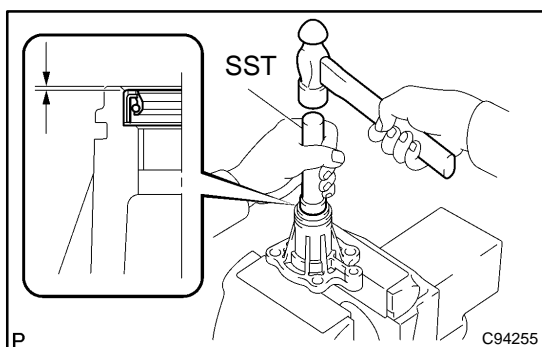
**12. INSTALL CONTROL SHAFT COVER OIL SEAL**

- (a) Using SST and a hammer, install a new control shaft cover oil seal to the control shaft cover.
SST 09950-60010 (09951-00220), 09950-70010 (09951-07100)
Drive in depth: 0.7 ± 0.5 mm (0.0276 ± 0.0197 in.)
- (b) Coat the lip of control shaft cover oil seal with MP grease.

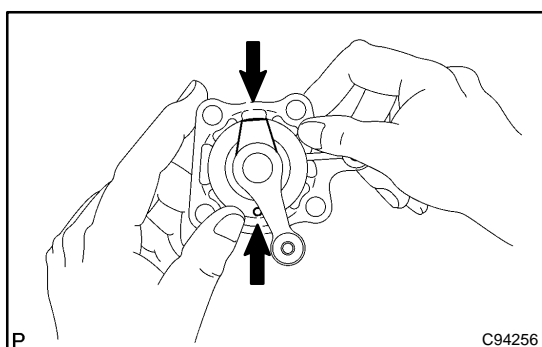
**13. INSTALL CONTROL SHAFT COVER**

- (a) Coat the shift & select lever shaft boot with MP grease, install it to the control shaft cover.
- (b) Install the control shaft cover to the shift & select lever.
HINT:
Install the dust boot with the projection up and the hole side down.
- (c) Coat the shift & select lever shaft with MP grease.

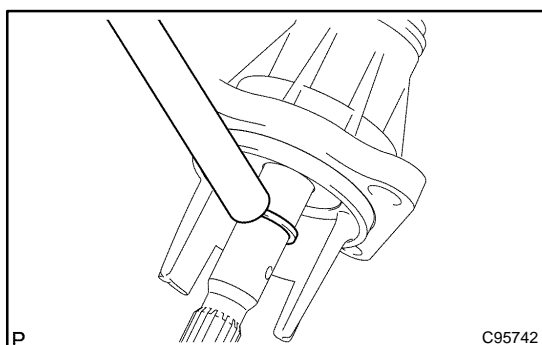

- (d) Using a brass bar and a hammer, tap in the snap ring to the shift & select lever shaft.

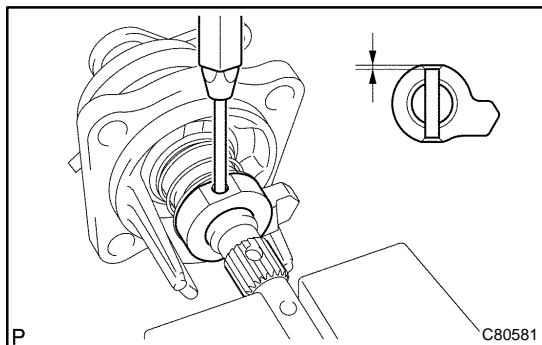
**14. INSTALL SELECT INNER LEVER**

- (a) Coat the select spring seat No.1 with MP grease, install it to the shift & select lever shaft.
- (b) Install the select return spring and select inner lever to the shift & select lever shaft.
- (c) Using a pin punch (ϕ 5 mm) and a hammer, install the slotted pin to the select lever inner lever.

Drive in depth: 3.0 – 4.0 mm (0.1181 – 0.1575 in.)

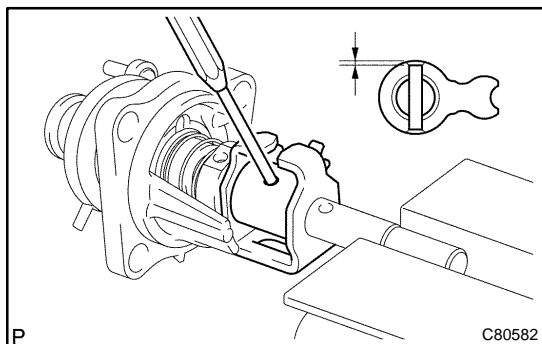
**15. INSTALL SHIFT LEVER INNER NO.1**

- (a) Coat the shift interlock plate and shift lever inner No.1 with MP grease.
- (b) Install the shift interlock plate with shift lever inner No.1 to the shift & select lever shaft.
- (c) Using a pin punch (ϕ 5 mm) and a hammer, install the slotted pin to the shift lever inner No.1.

Drive in depth: 0 ± 0.5 mm (0 ± 0.0197 in.)

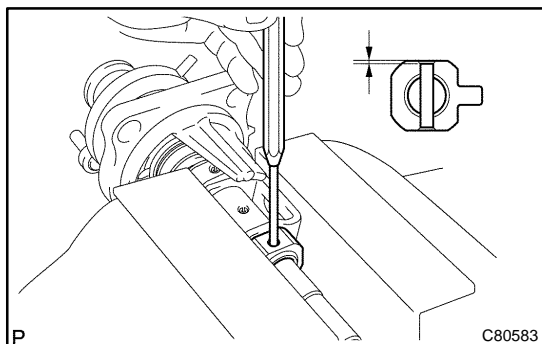
**16. INSTALL SHIFT LEVER INNER NO.2**

- (a) Install the shift lever inner No.2 to the shift & select lever shaft.
- (b) Using a pin punch (ϕ 5 mm) and a hammer, install the slotted pin to the shift lever inner No.2.

Drive in depth: 0 ± 0.5 mm (0 ± 0.0197 in.)

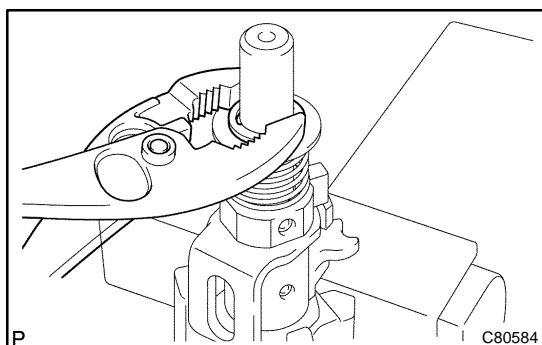
**17. INSTALL SELECT SPRING SEAT NO.2**

- (a) Coat the select spring seat No.2 with MP grease, install it with select return spring to the shift & select lever shaft.
- (b) Using a plier, install the E-ring to the shift & select lever shaft.

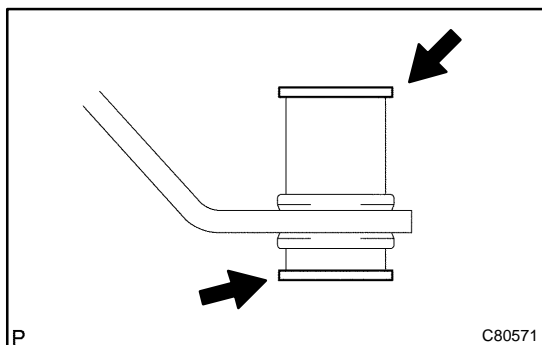
**18. INSTALL SELECTING BELLCRANK NO.2 BUSH**

- (a) Coat the selecting bellcrank No.2 bushes with MP grease, install them to the selecting bellcrank.

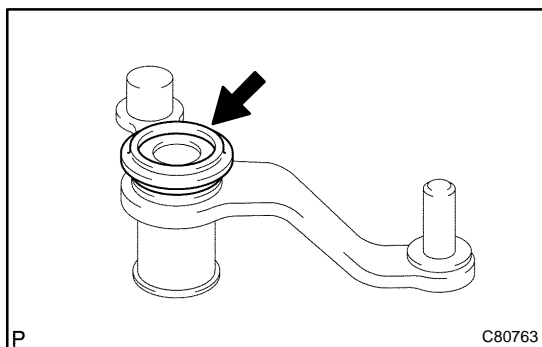

19. INSTALL SELECTING BELLCRANK DUST COVER NO.2

- (a) Coat the selecting bellcrank dust cover No.2 with MP grease, install it to the selecting bellcrank No.2.

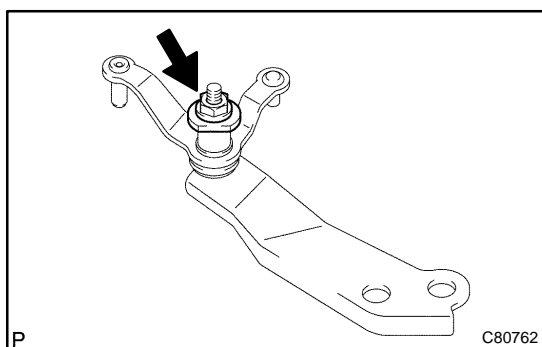

20. INSTALL SELECTING BELL CRANK NO.2

- (a) Install the selecting bellcrank No.2, selecting bellcrank No.2 plate washer and spring washer with nut.
Torque: 11.8 N·m (120 kgf·cm, 9 ft·lbf)

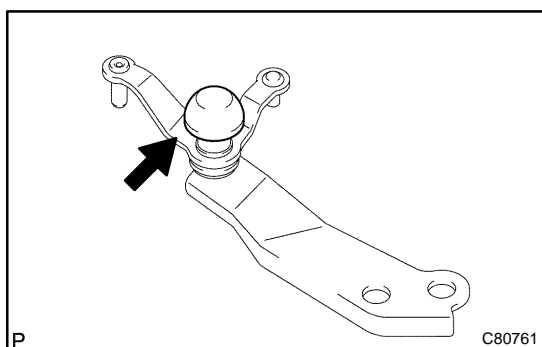

21. INSTALL SELECTING BELLCRANK DUST COVER NO.1

- (a) Install the selecting bellcrank dust cover No.1 to the selecting bellcrank assy.

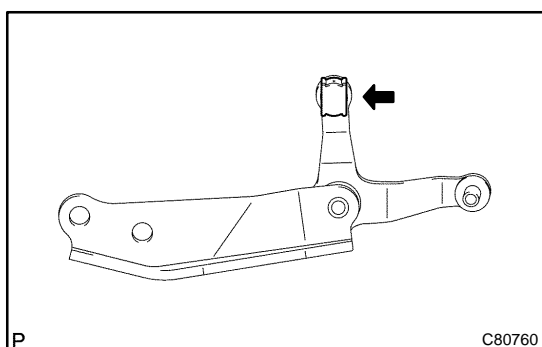

22. INSTALL CONTROL SHIFT LEVER BUSH

- (a) Coat the control shift lever bush with MP grease, install it to the selecting bellcrank assy.